

# TECHNICAL INFORMATION

**Models No.** ▶ MT602, MT603

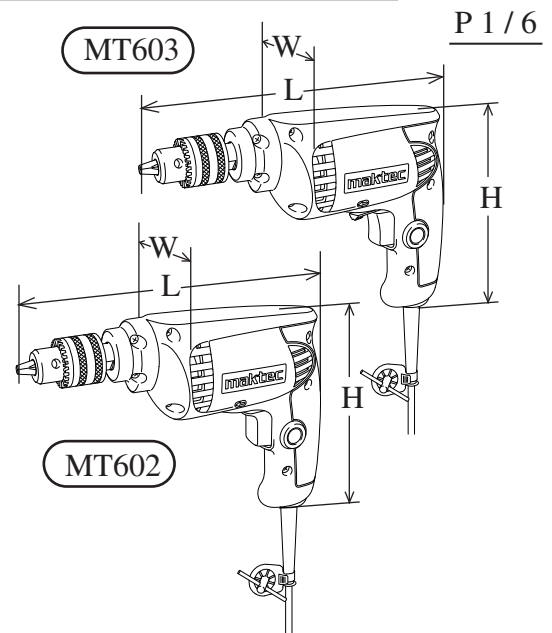
**Description** ▶ Drill 10mm (3/8")

## CONCEPTION AND MAIN APPLICATIONS

The above **maktec** drills have been designed as a medium class model between Mod.MT600 and MT650.

- \* MT602 : 1. Compact design and easy to handle  
2. Less expensive, but service life is long as the existing models.  
3. Easy to repair construction

\* MT603 : Equipped with variable speed control and reverse switch in addition to the above features.



Dimensions : mm ( " )		
Model No.	MT602	MT603
Length ( L )	228 (9)	
Width ( W )	64 (2-1/2)	
Height ( H )	175 (6-7/8)	

## ► Specification

Voltage (V)	Current (A)	Cycle (Hz)	Continuous Rating (W)		Max. Output(W)
			Input	Output	
110	4.3	50 / 60	450	230	350
120	4.0	50 / 60	450	230	350
220	2.2	50 / 60	450	230	350
230	2.1	50 / 60	450	230	350
240	2.0	50 / 60	450	230	350

Model No.	MT602	MT603
No load speed : (min - max rpm)	3,000	0 - 3,000
Keyless chuck	No	
Chuck ability : mm ( " )	1.5 - 10 (1/16 - 3/8)	
Drilling capacity : mm ( " )	in Steel	10 (3/8)
	in Wood	25 (1)
Reverse switch	No	Yes
Variable switch	No	Yes
Protection against electric shock	Double insulation	
Cord length : m ( ft )	2.0 (6.6)	
Net weight :Kg ( lbs )	1.2 (2.6)	

## ► Standard equipment

- \* Chuck key S10 ..... 1 pc.
- \* Key holder 10 ..... 1 pc.

< Note > The standard equipment for the tool shown may differ from country to country.

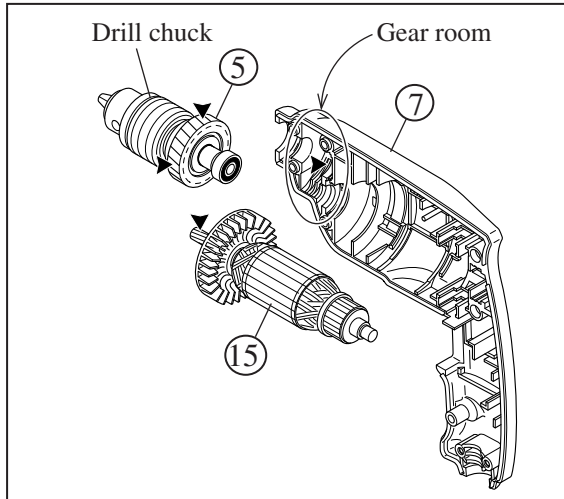
## Repair

### < 1 > Lubrication

Apply Makita grease N. No.1 to the following portions designated by black triangle to protect parts and product from unusual abrasion. See Fig. 1.

Item No.	Descriptions	The portion to lubricate	Amount of lubricant
⑤	Helical gear	Teeth portion	Approx. 3.0 g in total
⑦	Housing R or L	Gear room	
⑮	Armature	Teeth portion	

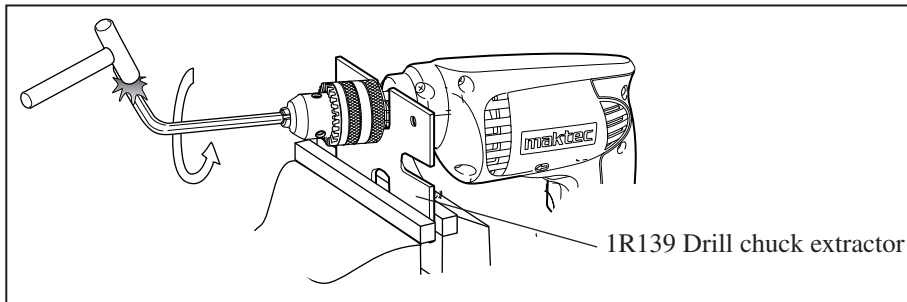
Fig. 1



### < 2 > Removing drill chuck

Firmly hold No.1R139 "Drill chuck extractor" with vise. And lock spindle with the drill chuck extractor. Hold hex wrench with drill chuck firmly. Strike the hex wrench with hammer so that the drill chuck turns anti-clockwise. See Fig. 2. So drill chuck can be removed from spindle.

Fig. 2

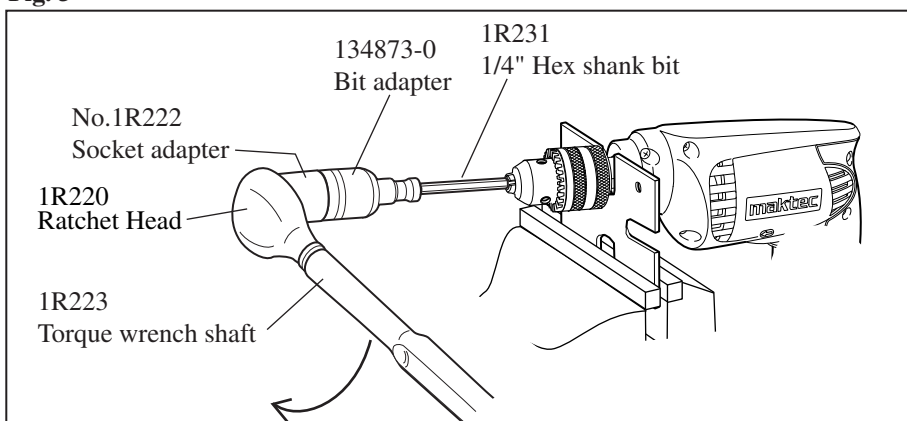


### < 3 > Mounting drill chuck

1. Set the repairing tools, No.1R222, 1R220, 1R223, 134873-0, 1R231 as illustrated in Fig. 3.
2. Hold No.1R231 with drill chuck firmly.
3. Turn 1R223 clockwise. Then, drill chuck can be mounted to spindle.

**The fastening torque for drill chuck is 25.52 - 29.42N.m (250 - 300Kgfcm).**

Fig. 3

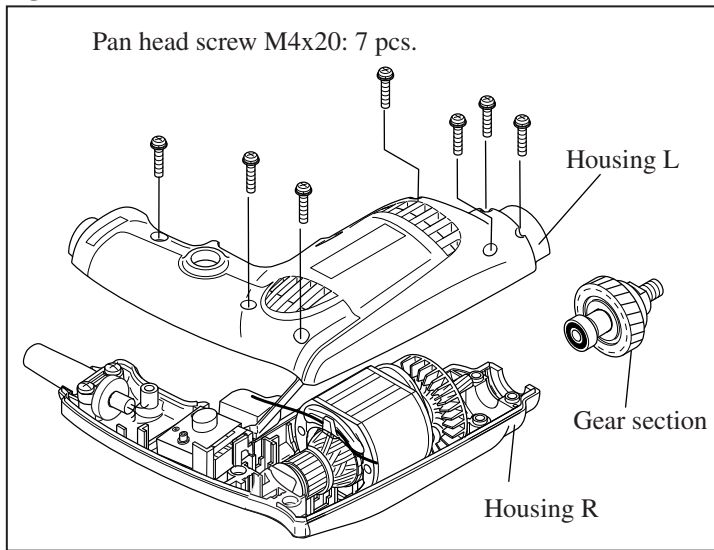


# ▶ Repair

## < 4 > Disassembling gear section

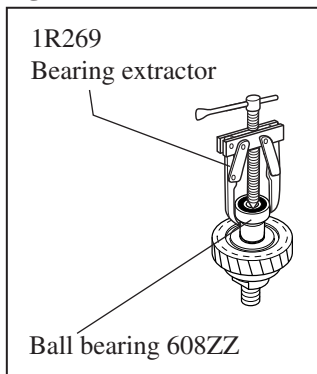
- (1) Separate housing L after removing 7 pcs. of pan head screw M4x20. See **Fig. 4**.
- (2) Remove gear section. See **Fig. 4**.

**Fig. 4**

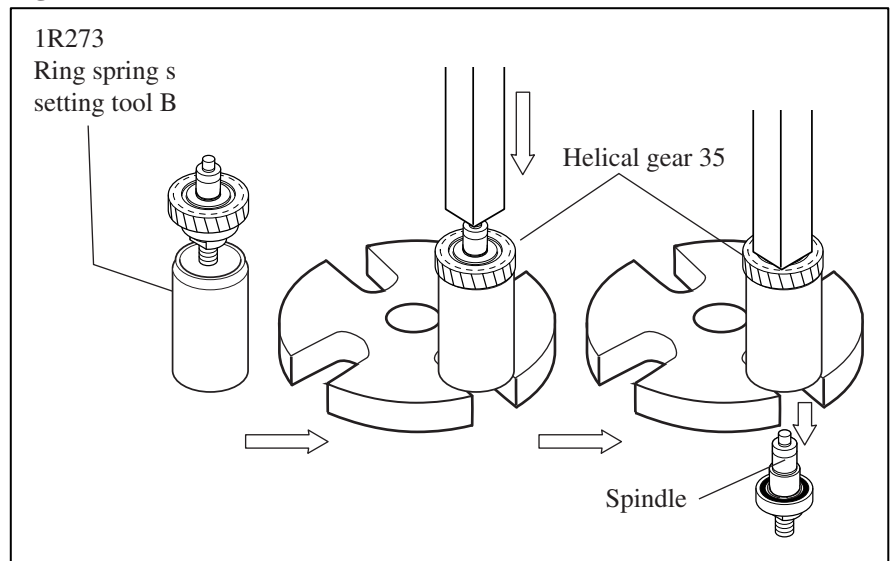


- (3) Remove ball bearing 608ZZ from spindle with 1R269 "Bearing extractor". See **Fig. 5**.
- (4) Put the gear section on 1R273 "Ring Spring Setting Tool B", and press the spindle with arbor press. Then, helical gear 35 can be separated from the spindle. See **Fig. 6**.

**Fig. 5**

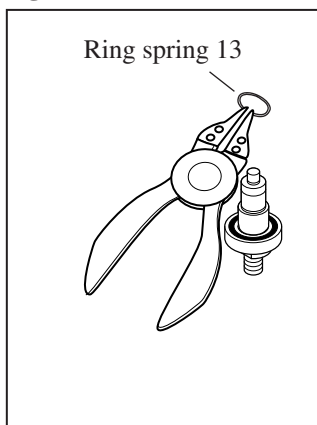


**Fig. 6**

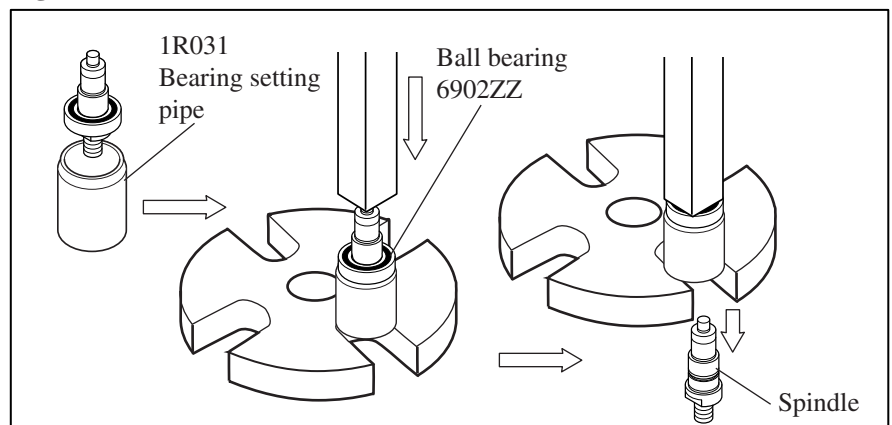


- (5) Remove ring spring 13. See **Fig. 7**.
- (6) Put the gear section on 1R031 "Bearing Setting Pipe", and press the spindle with arbor press. Then, ball bearing 6902ZZ can be separated from spindle. See **Fig. 8**.

**Fig. 7**



**Fig. 8**

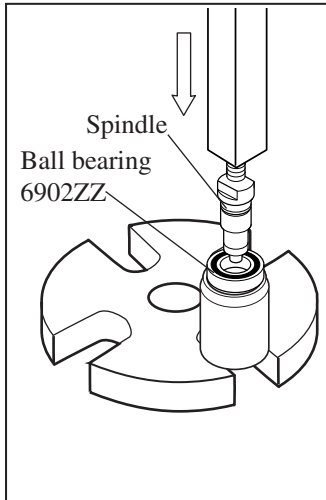


## Repair

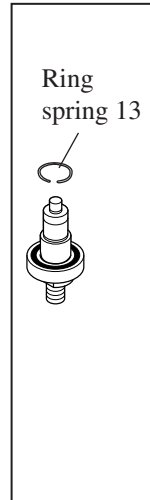
### < 5 > Assembling gear section

- (1) Mount ball bearing 6902ZZ to spindle. See **Fig. 9**.
- (2) Mount ring spring 13 for securing ball bearing 6902ZZ. See **Fig. 10**.
- (3) Mount helical gear 35 by pressing the spindle with arbor press. See **Fig. 11**.
- (4) Mount ball bearing 608ZZ by pressing the spindle with arbor press. See **Fig. 12**.  
The gear section has been completed in this step.
- (5) Mount the gear section to the housing, while engaging helical gear 35 with armature gear.  
And then secure housing L with 7 pcs. of pan head screw M4x20. See **Fig. 13**.

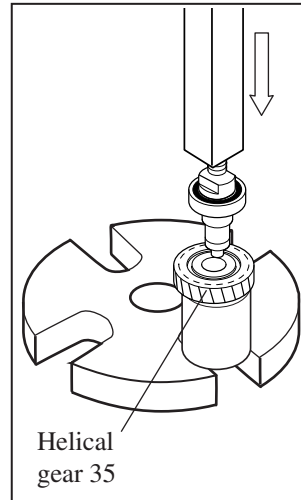
**Fig. 9**



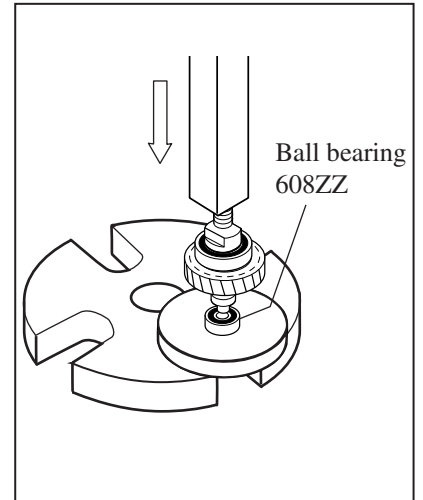
**Fig. 10**



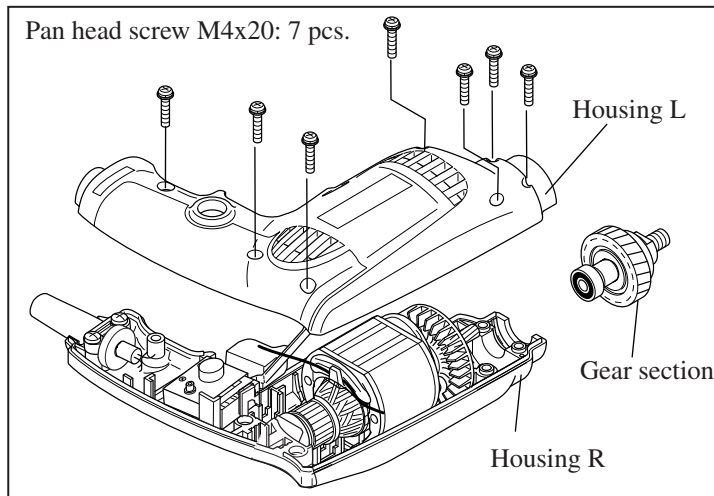
**Fig. 11**



**Fig. 12**



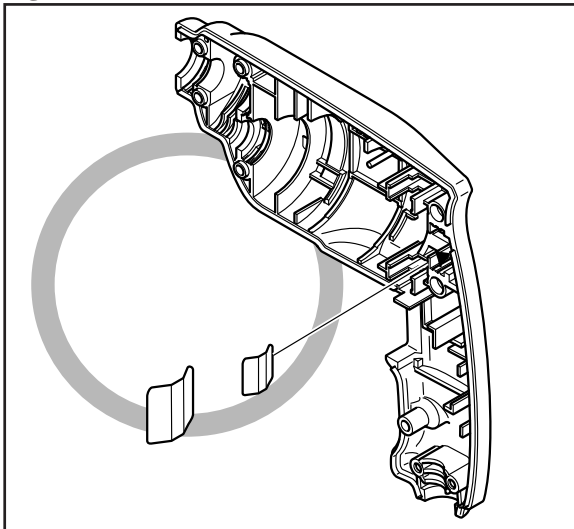
**Fig. 13**



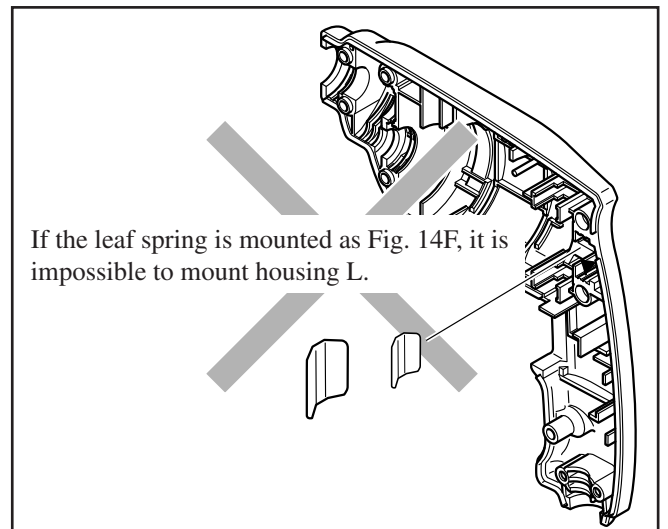
### < 6 > Note on assembling armature

Before mounting armature, mount leaf spring to the housing. See **Fig. 14R**.






**Fig. 14R**

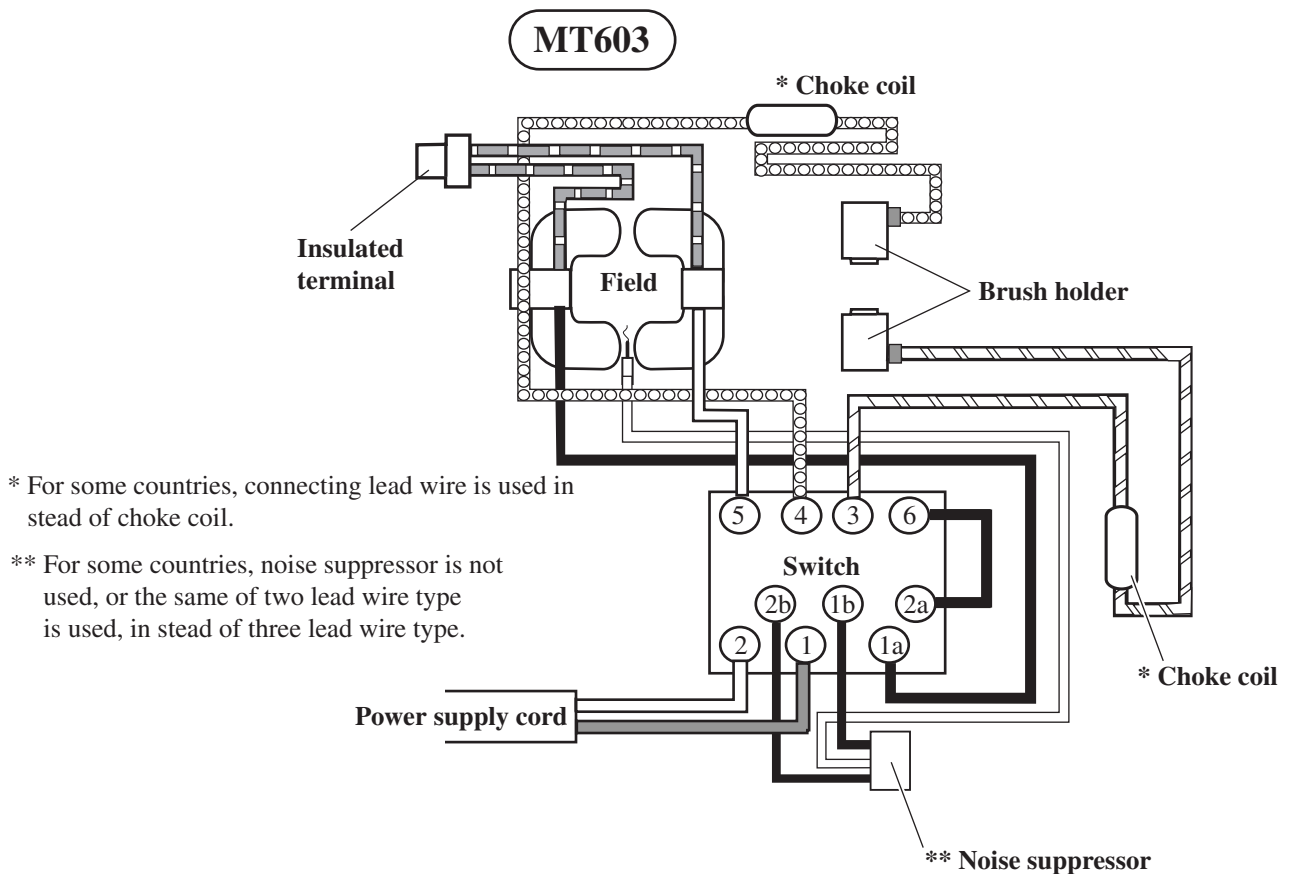
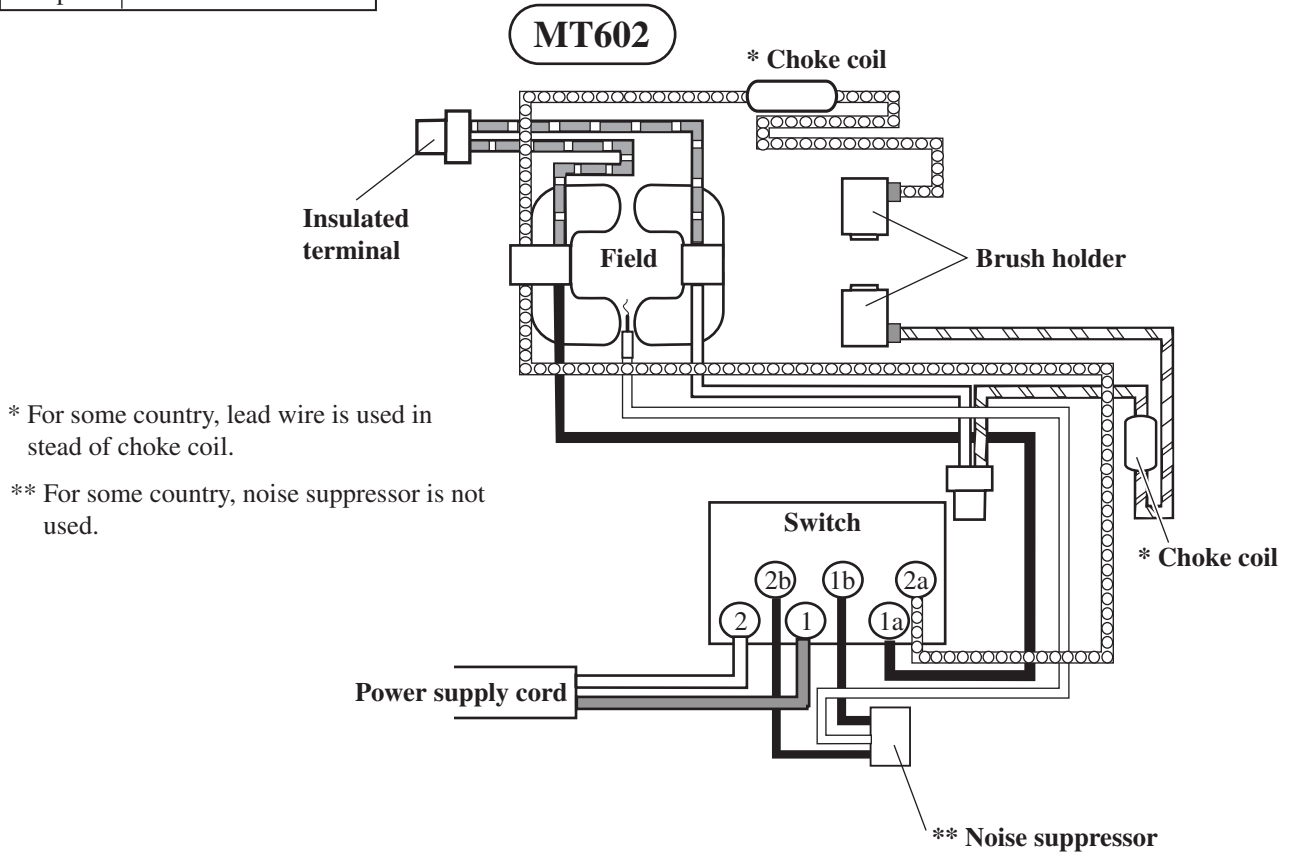


**Fig. 14F**



▶ **Circuit diagram**

Color index of lead wires' sheath	
Black	
White	
Red	
Orange	
Purple	



▶ **Wiring diagram**

