

**Model No.** ▶ MT600, MT601

**Description** ▶ Drill 10mm (3/8")

## CONCEPT AND MAIN APPLICATIONS

New power tool series from MAKITA

\* MT600 : 1. Less expensive, but service life is long as the existing models.

2. Easy to repair construction

\* MT601 : Equipped with keyless drill chuck in addition to the above features.

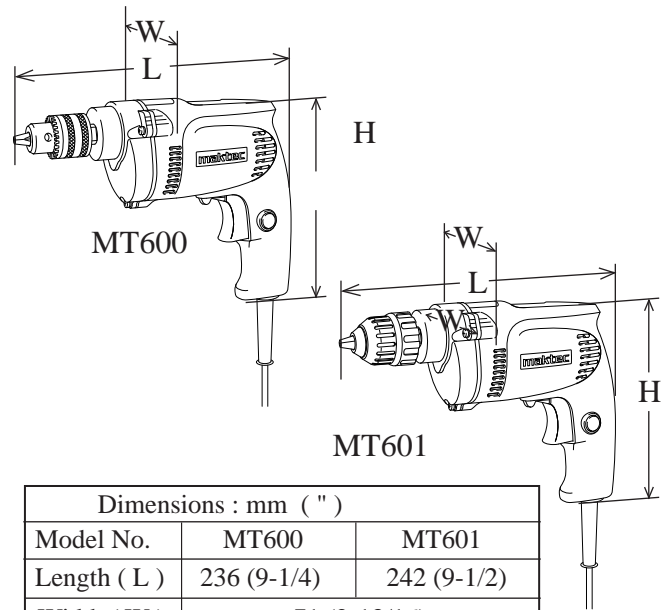

Dimensions : mm ( " )		
Model No.	MT600	MT601
Length ( L )	236 (9-1/4)	242 (9-1/2)
Width ( W )	71 (2-13/16)	
Height ( H )	194 (7-5/8)	

## ▶ Specification

Voltage (V)	Current (A)	Cycle (Hz)	Continuous Rating (W)		Max. Output(W)
			Input	Output	
* 110	3.3	50 / 60	350	180	230
220	1.7	50 / 60	350	180	230
220 / 230	1.6	50 / 60	350	180	230
230 / 240	1.5	50 / 60	350	180	230

\* The data with 110V is available only for MT600.

Model No.	MT600	MT601
No load speed : (min - max rpm)	0 - 2,500	
Keyless chuck	No	Yes
Chuck ability : mm ( " )	1.5 - 10 (1/16 - 3/8)	
Drilling capacity : mm ( " )	in Steel	10 (3/8)
	in Wood	25 (1)
Reverse switch	Yes	
Protection from electric shock	by double insulation	
Cord length : m ( ft )	2.0 (6.6)	
Net weight :Kg (lbs)	1.4 (3.1)	

## ▶ Standard equipment

\* Chuck key ..... 1 pc. (available only for MT600)

< Note > The standard equipment for the tool shown may differ from country to country.

## ▶ Optional accessories

## < 1 > Lubrication

Apply MAKITA grease N. No.1 to the following portions marked with black triangle to protect parts and product from unusual abrasion. See Fig. 1.

7. Helical gear 39 : approx. 3.5g (0.12 oz)

13. Armature, gear portion : approx. 3.5g (0.12 oz)

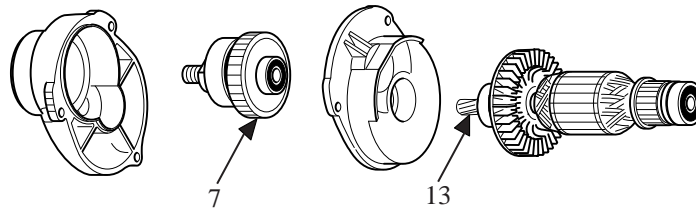

Fig. 1

## < 2 > Removing drill chuck

Firmly hold No.1R139 "Drill chuck extractor" with vise. And lock spindle with the drill chuck extractor. Hold hex wrench with drill chuck firmly. Strike the hex wrench with hammer so that the drill chuck turns anti-clockwise. See Fig. 2. So drill chuck can be removed from spindle.

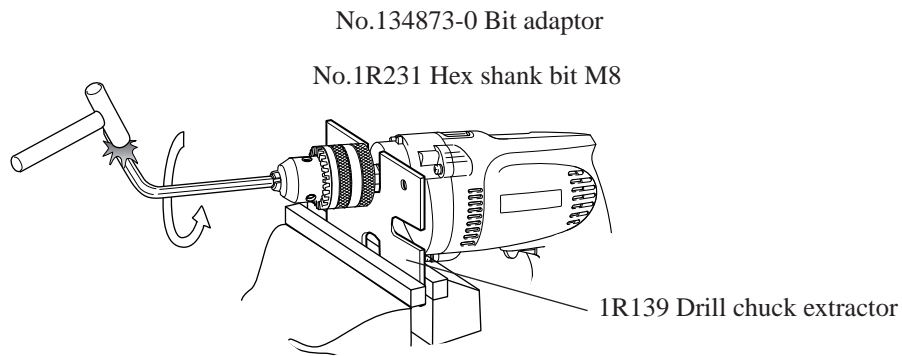

Fig. 2

## < 3 > Mounting drill chuck

Firmly hold No.1R139 "Drill chuck extractor" with vise. And lock spindle with the drill chuck extractor. Hold the repairing tools in Fig. 3A, with drill chuck as illustrated in Fig. 3. And turn torque wrench clockwise.

<Note in assembling>

Pre-set the fastening torque of the torque wrench with 15 - 20 N.m, when assembling.

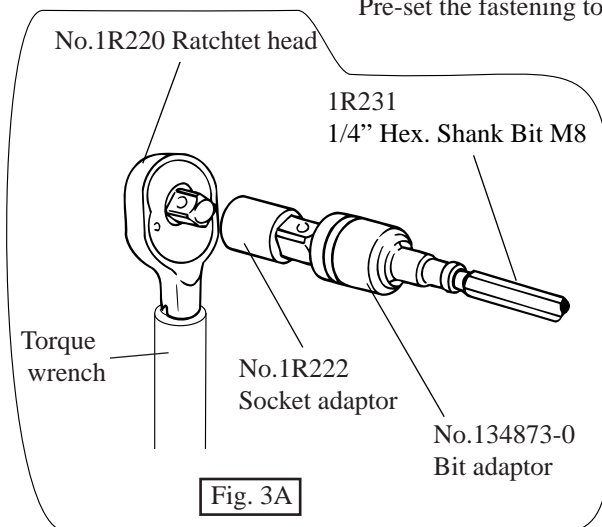

Fig. 3A

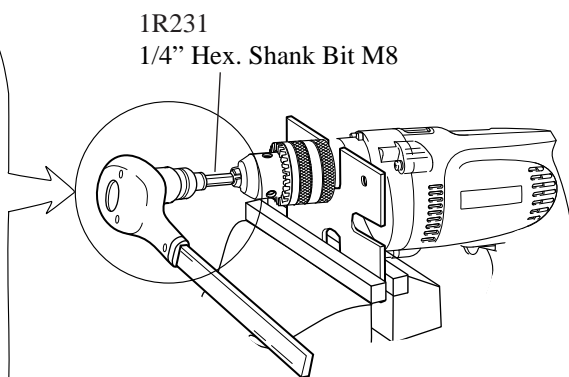
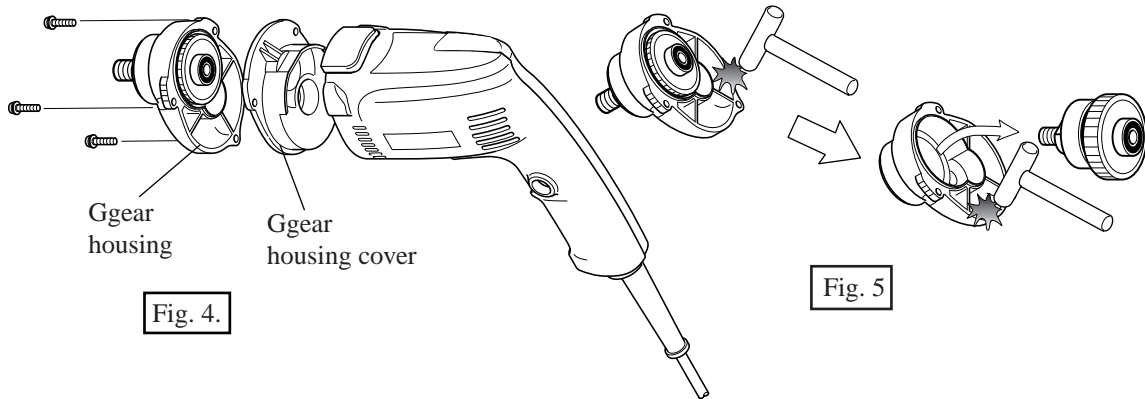

Fig. 3

< 4 > Disassembling gear section

- (1) After removing drill chuck, separate gear housing from motor housing by unscrewing 3 pcs. of pan head screws M4x18. See Fig. 4.  
Tap the edge of gear housing with plastic hammer. So, helical gear 39 section can be removed from gear housing. See Fig. 5.



- (2) Remove ball bearing 607ZZ with No.1R269 "Bearing Extractor as illustrated in Fig. 5.  
Hold the gear section (helical ear 39, spindle, ring 12 and ball bearing 6202ZZ) with No.1R139 "Drill chuck extractor" on the turn base of arbor press. And then, remove helical gear 39 by pressing down spindle as illustrated in Fig. 6.

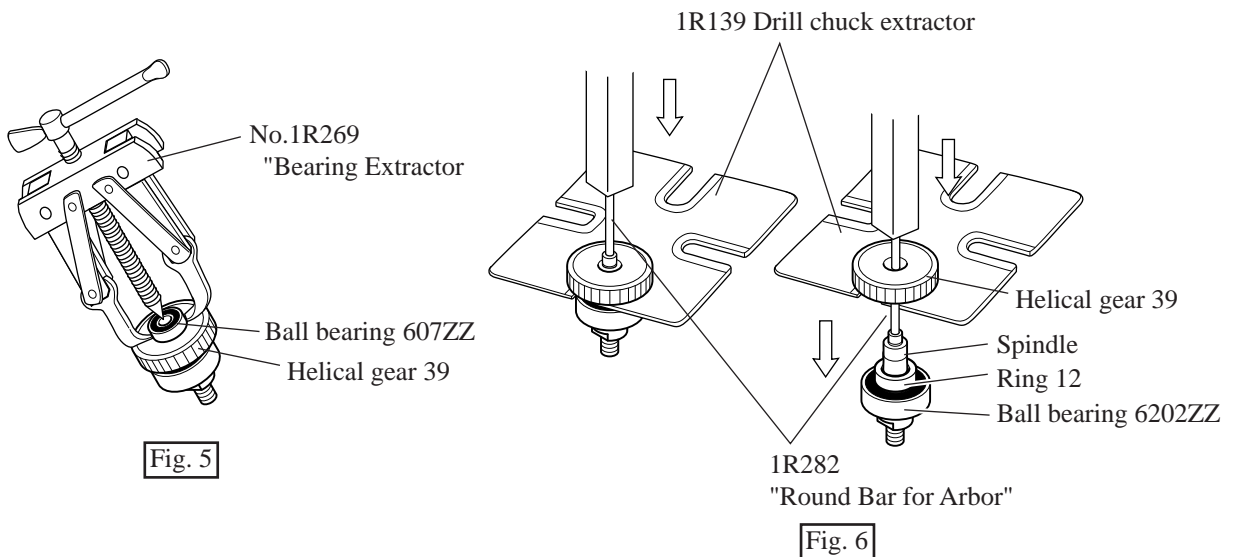

- (3) Remove ring 12. Hold spindle with No.1R139 "Drill chuck extractor" on the turn base of arbor press. And then, remove ball bearing 6202ZZ by pressing down spindle as illustrated in Fig. 7.

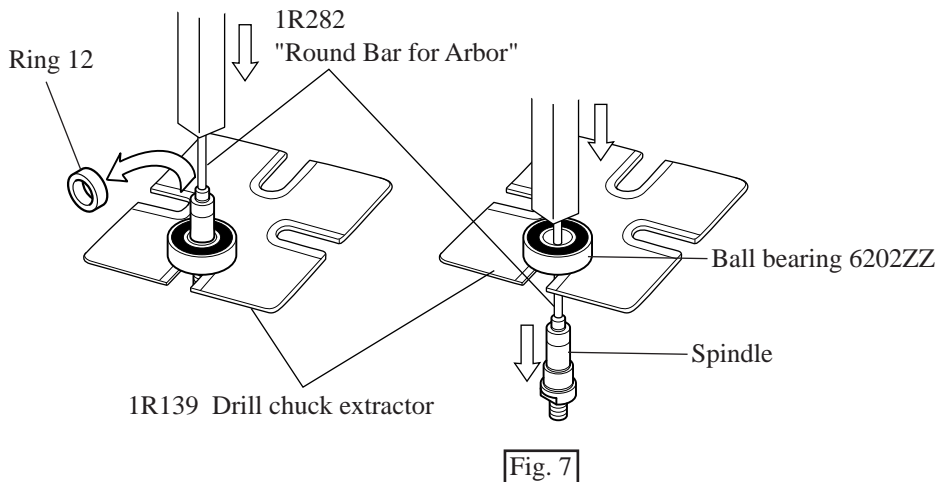

< 5 > Assembling gear section

- (1) Accepting ball bearing 6202DDW with No.1R217 "Ring 22", mount spindle to the ball bearing 6202DDW by pressing with arbor press. See Fig. 8.  
Mount ring 12 and helical gear 39 to spindle with your hand. See Fig. 9. And then, press them with arbor press finally. See Fig. 10.

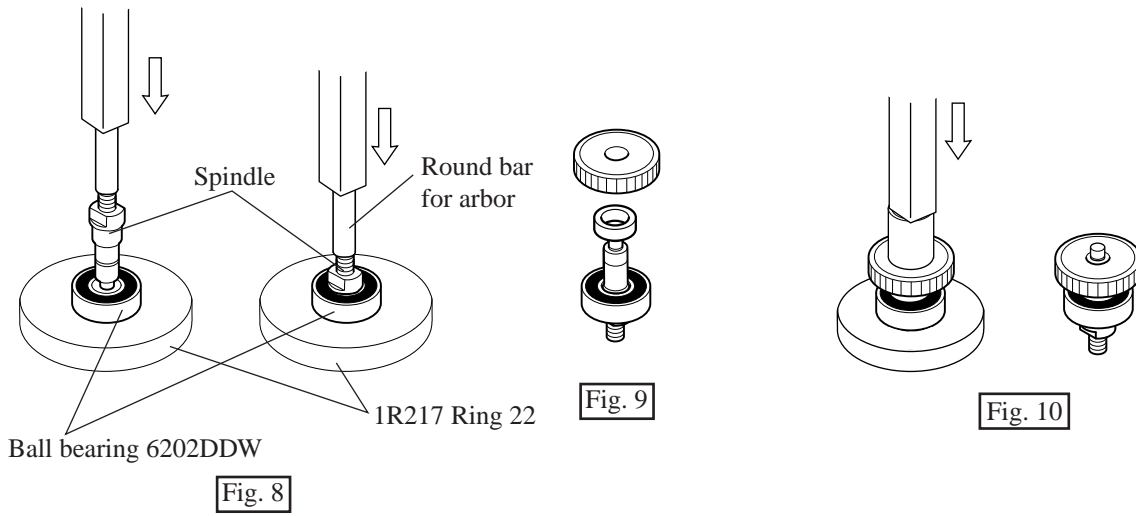

- (2) Mount ball bearing 607ZZ by pressing with arbor press as illustrated in Fig. 11.  
Mount the gear unit (spindle, ball bearing 6202DDW, ring 12, helical gear 39 and ball bearing 607ZZ) to gear housing. And then, mount gear housing in which the gear unit has been mounted, to motor housing as illustrated in Fig. 12.

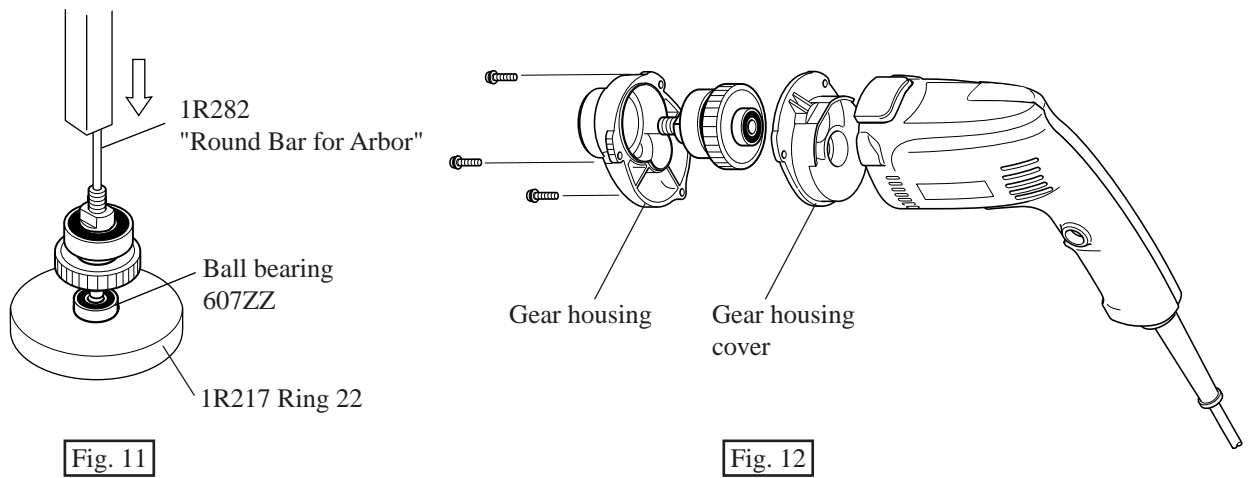

► **Circuit diagram**

Color index of lead wires	
Black	
White	
Red	
Orange	
Purple	

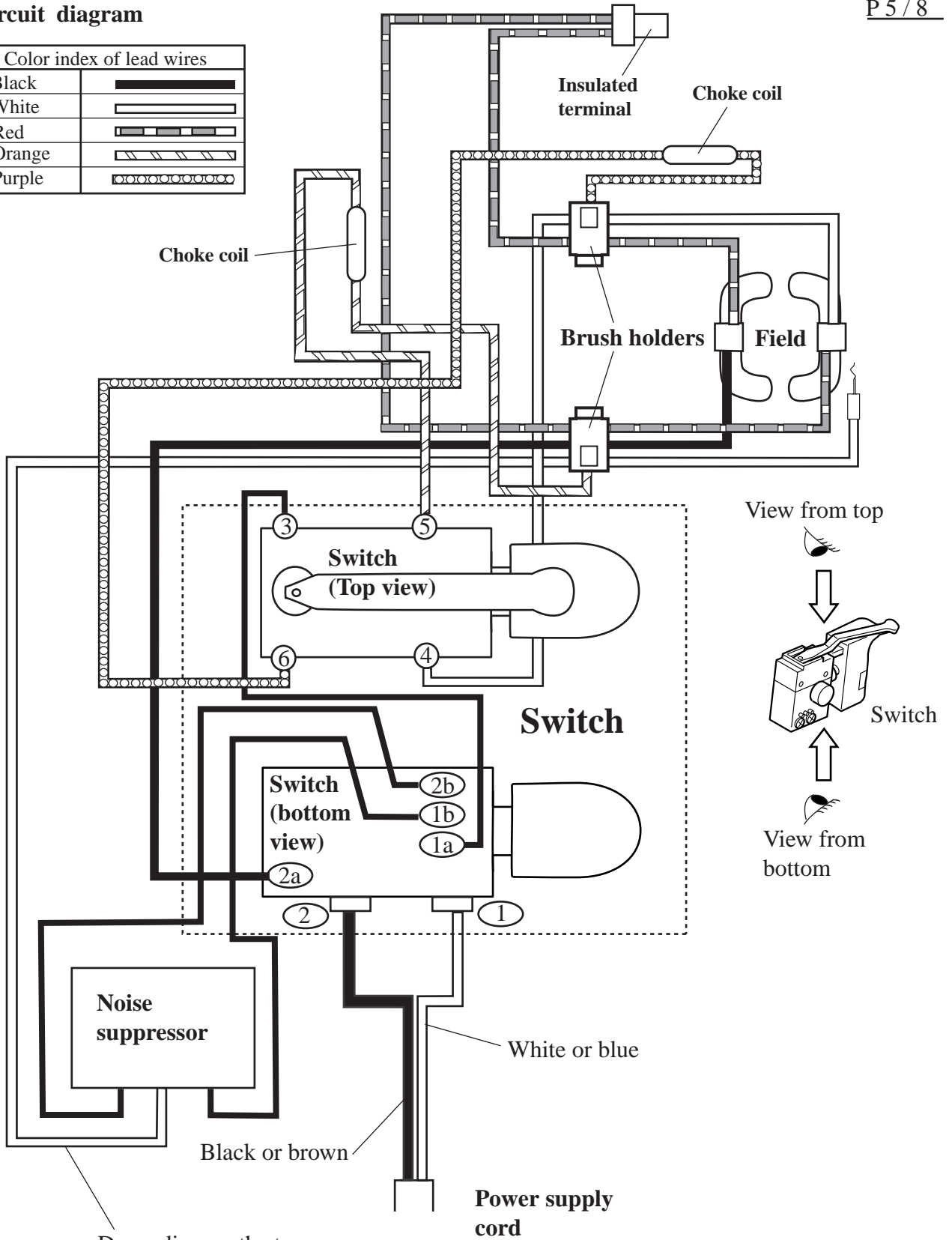

Depending on the type of noise suppressor, this white lead wire may not be used.

## ▶ Wiring diagram

Wire the field lead wire as illustrated below.

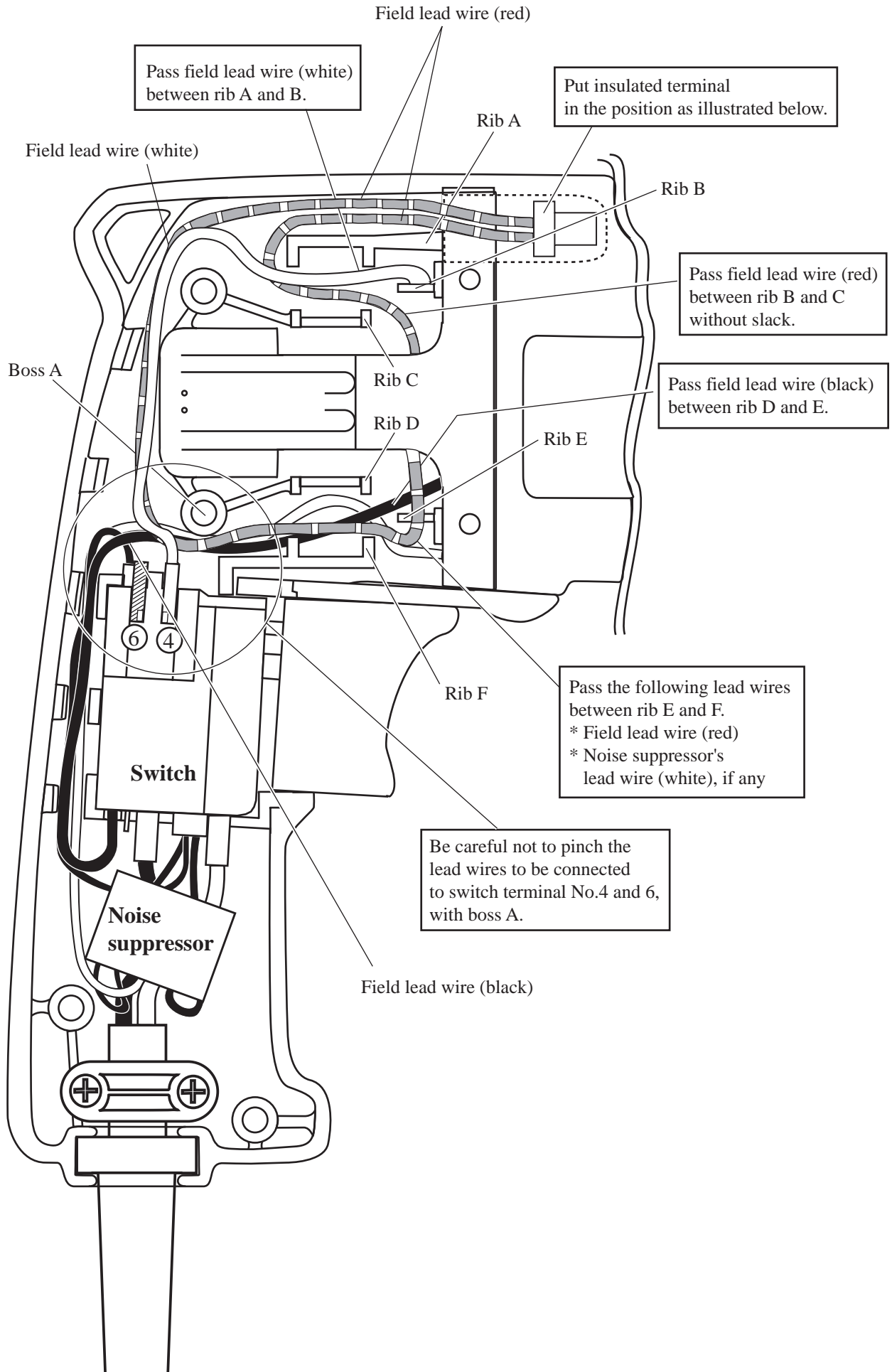

## ▶ Wiring diagram

Wire the brush holders' lead wires as illustrated below, in case of with choke.

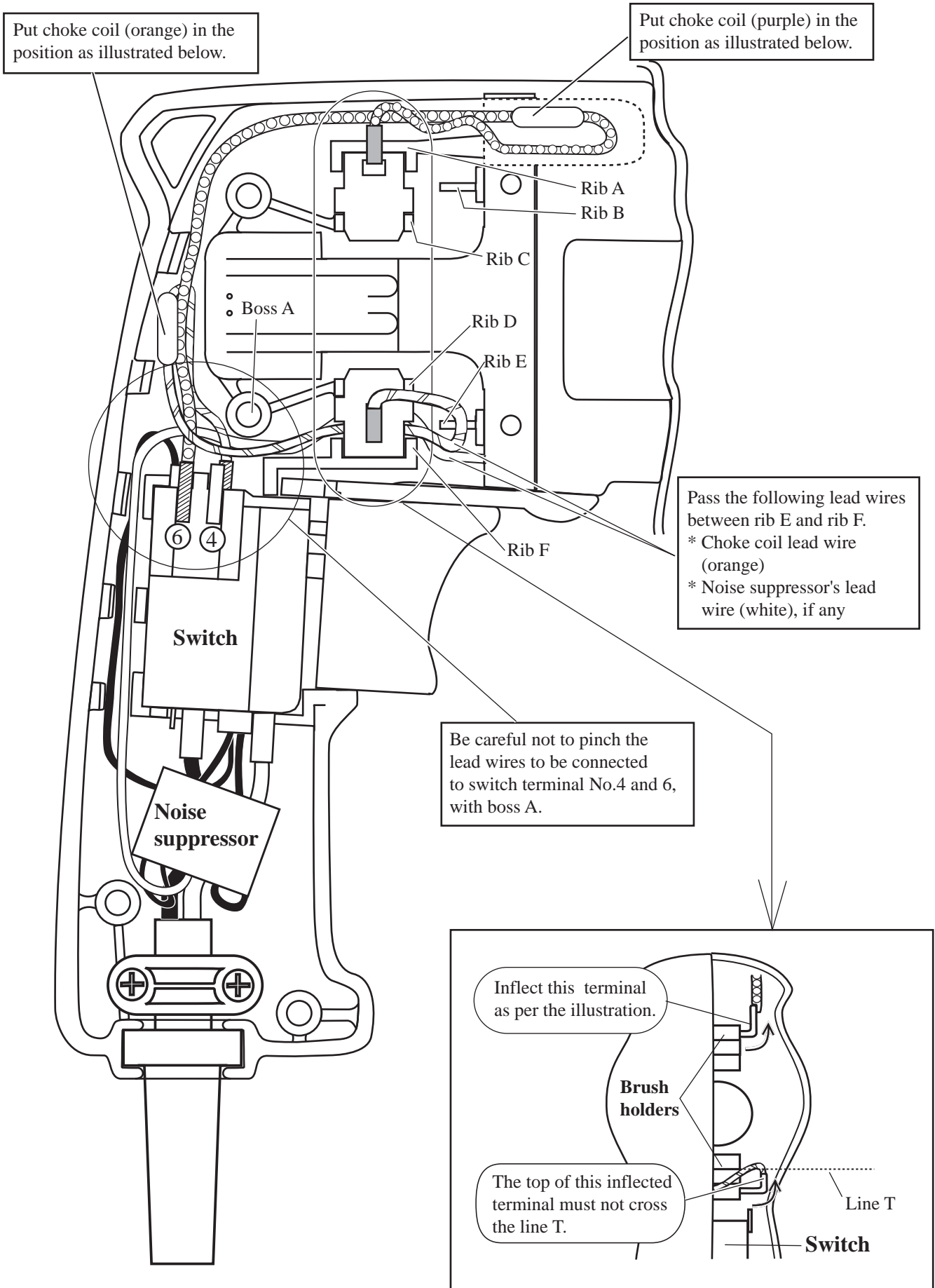

## ▶ Wiring diagram

Wire the brush holders' lead wires as illustrated below, in case of with choke.

