

**Models No.** ▶ MT066, MT067

**Description** ▶ Cordless drills 10mm (3/8")

## CONCEPT AND MAIN APPLICATIONS

Two 7.2V cordless drills with stick type battery have been added to **maktec** series models providing industrial performance and durability at less expense. Model MT066 features keyless drill chuck, and Model MT067 features keyed drilled chuck.

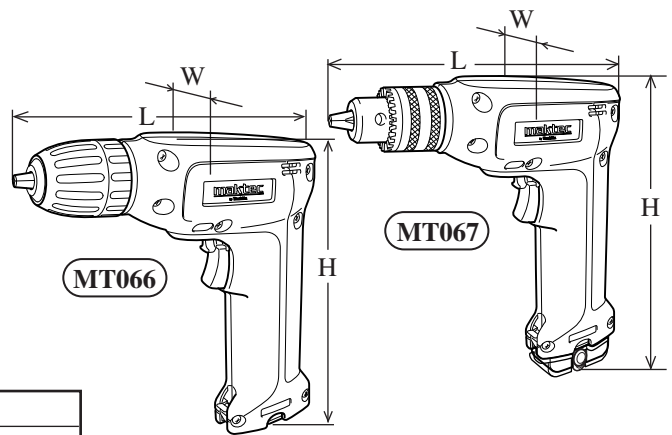

Listed below are variations of MT066 and MT067.

Model No.	Items included as a set	
MT066SK	Ni-Cd battery 7050 x 1 pc.	Charger DC1251
MT066SK2	Ni-Cd battery 7050 x 2 pcs.	
MT066SK3	Ni-Cd battery 7050 x 3 pcs.	
MT067SK	Ni-Cd battery 7050 x 1 pc.	
MT067SK2	Ni-Cd battery 7050 x 2 pcs.	
MT067SK3	Ni-Cd battery 7050 x 3 pcs.	
All of the above models come with the items listed below in the "Standard equipment" in addition to the above battery and charger.		

Dimensions : mm ( " )		
Model No.	MT066	MT067
Length ( L )	223 (8-3/4)	217 (8-1/2)
Width ( W )	52 (2-1/16)	52 (2-1/16)
Height ( H )	210 (8-1/4)	225 (8-7/8)

## ► Specification

Model No.		MT066	MT067
Battery	Voltage ( V )	7.2	
	Cell	Ni-Cd	
	Capacity ( Ah )	1.3	
No load speed : ( min -1= rpm )		600	
Keyless drill chuck		Yes	No
Chuck ability : mm ( " )		0.8 - 10 (1/32 - 3/8)	
Capacities	in Steel : mm ( " )	10 (3/8)	
	in Wood : mm ( " )	10 (3/8)	
	Screw : mm ( " )	ø4.5 x 20 (ø3/16 x 3/4)	
Max. fastening torque	Hard joint	7 N.m (62 in.lbs)	
	Soft joint	5 N.m (44 in.lbs)	
Reverse switch		Yes	
Net weight :Kg ( lbs )		1.1 (2.4)	

## ► Standard equipment

Model No.	MT066SK	MT066SK2	MT066SK3	MT067SK	MT067SK2	MT067SK3
Battery 7050 (Ni-Cd. 7.2V 1.3Ah)	1 pc.	2 pcs.	3 pcs.	1 pc.	2 pcs.	3 pcs.
Charger DC1251	1 pc.	1 pc.	1 pc.	1 pc.	1 pc.	1 pc.
Battery cover	1 pc.	2 pcs.	3 pcs.	1 pc.	2 pcs.	3 pcs.
Chuck key				1 pc.	1 pc.	1 pc.
Plastic carrying case	1 pc.	1 pc.	1 pc.	1 pc.	1 pc.	1 pc.

< Note > The standard equipment for the tool shown may differ from country to country.

## ► Repair

### < 1 > Lubrication

Apply MAKITA grease N. No.2 (total 5.0g) to the teeth of the gears designated by black triangle in order to protect parts and product from unusual abrasion. See **Fig. 1**.

**Fig. 1**

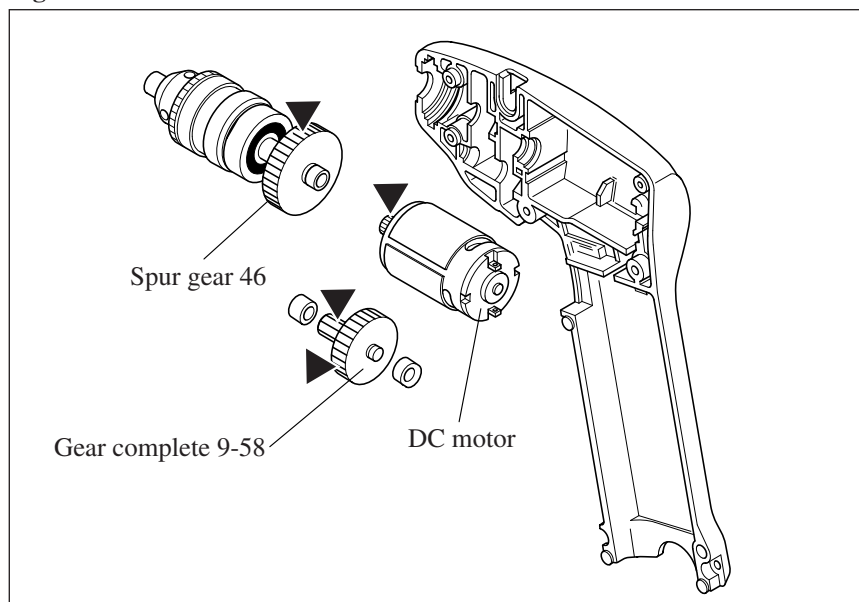

### < 2 > Removing drill chuck

1. Remove battery cartridge from the machine.
2. Open the jaws of drill chuck fully and remove pan head screw M5x22 by turning it clockwise. See **Fig. 2**.  
If it is difficult to remove M5x22 pan head screw using screwdriver, use Impact driver of electric power tool.
3. Hold hex wrench with drill chuck firmly and next hit the hex wrench with plastic hammer as illustrated in **Fig. 3**.  
Then drill chuck can be removed from spindle.

**Fig. 2**

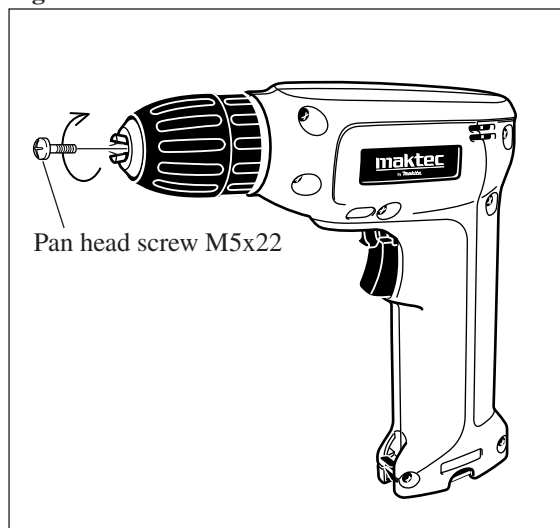

**Fig. 3**

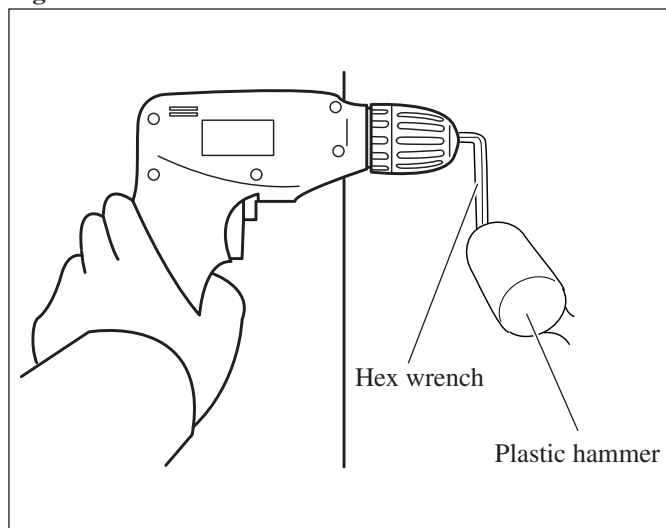

## ▶ Repair

### < 3 > Remounting drill chuck

1. Screw drill chuck until it is seated into the thread of spindle.
2. Hold hex wrench firmly with drill chuck, and hold the another end of hex wrench with vise. See **Fig. 4**.
3. Insert the fully charged battery cartridge into the above machine, and hold the machine so firmly that you can not be swung by the reaction torque when the machine is locked. See **Fig. 4**.
4. After shifting the revering switch lever so that the spindle rotates to the forward direction, pull the trigger to stat running for approx. 1 second. Now drill chuck is mounted to spindle.
5. Turn pan head screw M5x22 counterclockwise for securing drill chuck. Refer to **Fig. 2**.

**Fig. 4**

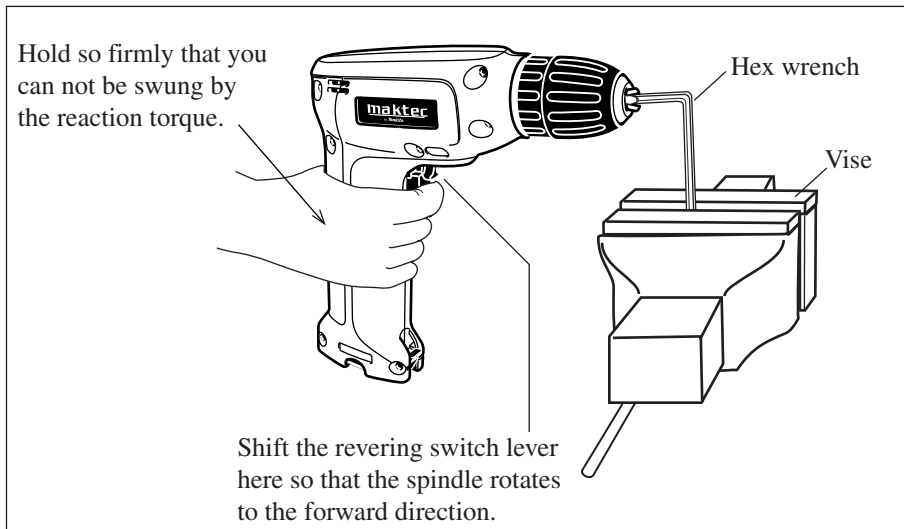

### < 4 > Replacing spur gear 46 and ball bearing 6200ZZ

1. Remove drill chuck as illustrated in **Fig. 2** and **Fig. 3**. Separate housing L from housing R in order to remove gear and spindle section.
2. Set the removed gear and spindle section on the turn base of arbor press using Bearing plate (Part No. 1R022) and Pipe ring (Part No. 1R023). And remove spur gear 46 from spindle using arbor press. See **Fig. 5**.
3. Remove ring spring 9 with Retaining ring S pliers (Part No. 1R004). See **Fig. 6**.
4. Set the removed spindle with ball bearing 6200ZZ on the turn base of arbor press as illustrated in **Fig. 7**. And press the spindle with arbor press to remove ball bearing 6200ZZ from spindle.

**Fig. 5**

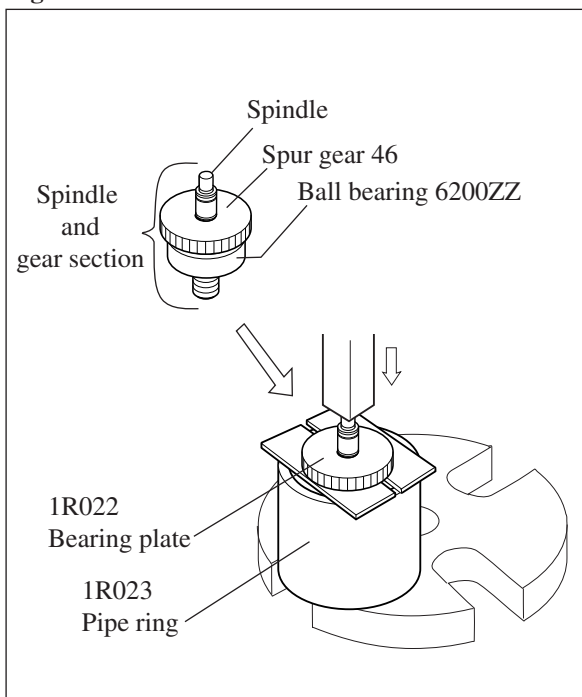

**Fig. 6**

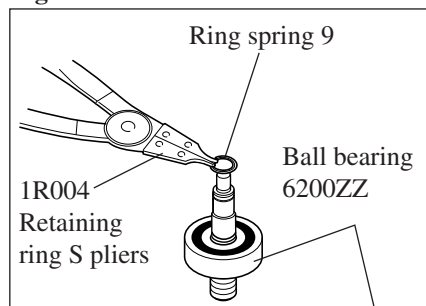

**Fig. 7**

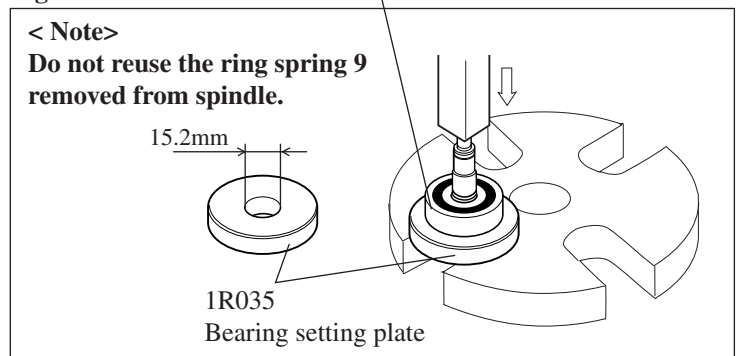

## ► Repair

5. Set the fresh ball bearing 6200ZZ on the turn base of arbor press. Refer to **Fig. 7**.  
And press the spindle using arbor press to mount ball bearing 6200ZZ to where it was.  
And secure the ball bearing 6200ZZ with ring spring 9. Refer to **Fig. 6**.
6. Set the fresh spur gear 46 on the turn base of arbor press. See **Fig. 8**.  
And mount spur gear 46 to spindle using arbor press.

**Fig. 8**

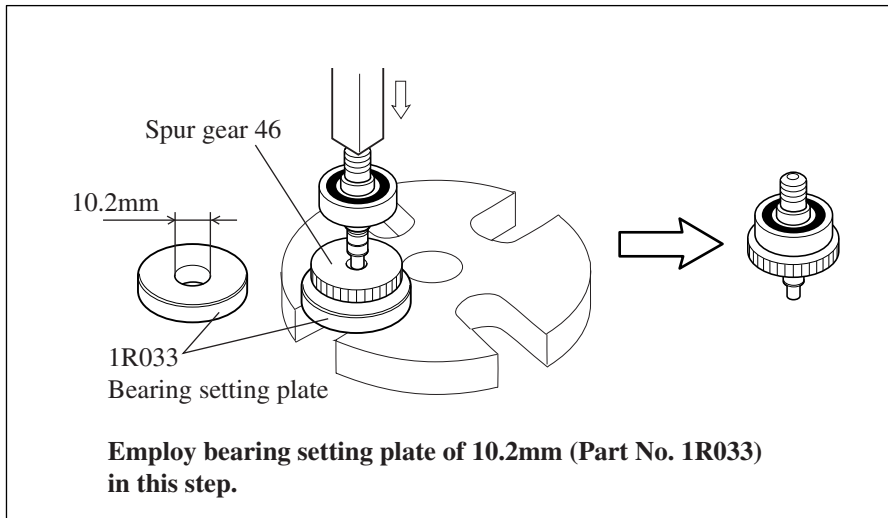

► **Circuit diagram**

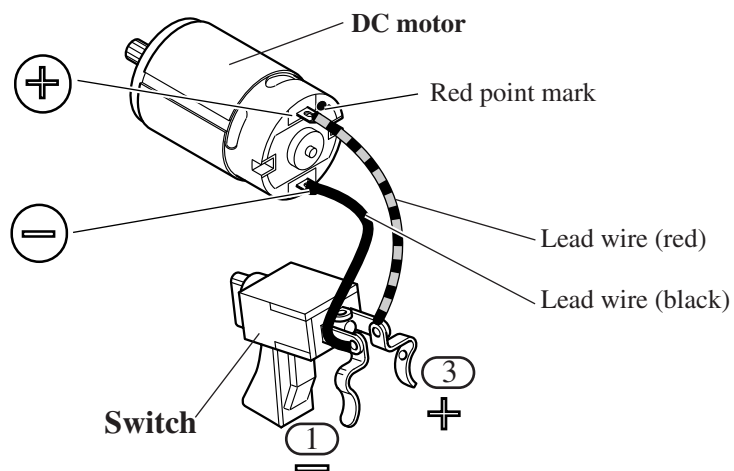

► **Wiring diagram**

Connect the lead wires to the terminals of DC motor as illustrated in **Fig. 9**.

**Fig. 9**

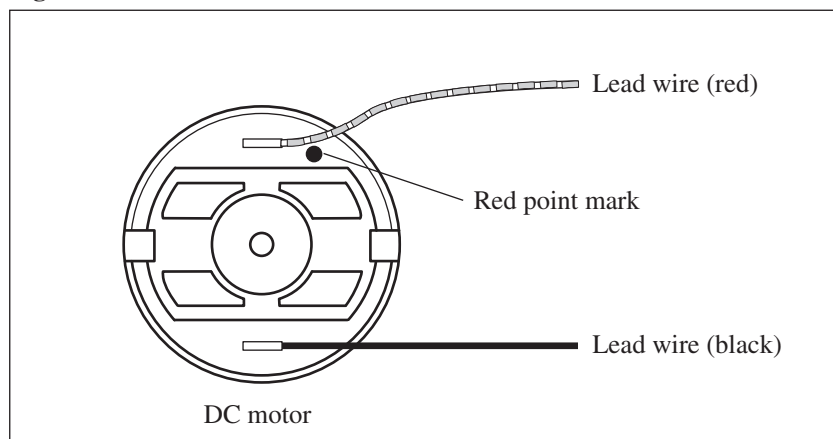

Hold the lead wires for connecting switch and DC motor using lead holders. See **Fig. 10**.

**Fig. 10**

