

# T ECHNICAL INFORMATION



PRODUCT

P 1 / 8

**Models No.** ▶ KP0800

**Description** ▶ Power Planer 82mm (3-1/4")

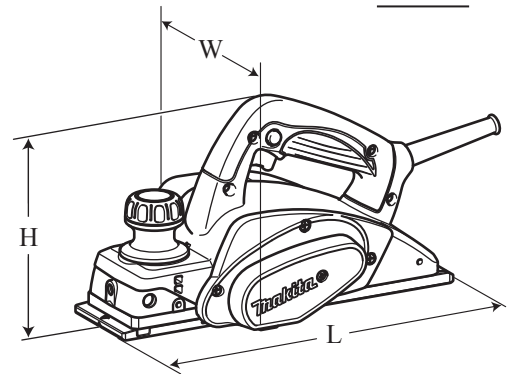
## CONCEPT AND MAIN APPLICATIONS

Model KP0800 has been developed as the successor model of N1900B and 1902.

Additionally to the same well balanced design for easy handling, features the following main advantages;

- Planing depth adjustment knob for precise depth setting
- Power input of 620W
- New aesthetic design

Also available with plastic carrying case as Model KP0800K.



Dimensions: mm (")	
Length (L)	285 (11-1/4)
Width (W)	158 (6-1/4)
Height (H)	158 (6-1/4)

## ► Specification

Voltage (V)	Current (A)	Cycle (Hz)	Continuous Rating (W)		Max. Output (W)
			Input	Output	
110	5.9	50/60	620	280	650
120	6.5	50/60	---	360	650
220	3.0	50/60	620	280	650
230	2.9	50/60	620	280	650
240	2.7	50/60	620	280	650

No load speed: min-1=rpm		17,000
Capacities: mm (")	Planing width	82 (3-1/4)
	Planing depth	2.5 (3/32)
	Shiplapping	9 (11/32)
Protection against electric shock		Double insulation
Power supply cord: m (ft)		Brazil, Australia: 2.0 (6.6), Other countries: 2.5 (8.2)
Net weight*: kg (lbs)		2.6 (5.7)

\* Weight according to EPTA-Procedure 01/2003

## ► Standard equipment

- Planer blade (re-sharpenable type) or T.C.T. Mini planer blade (disposable type)
- Sharpening holder assembly (for countries using re-sharpenable type Planer blade)
- Dressing stone (for countries using re-sharpenable type Planer blade)
- Blade gauge assembly
- Socket wrench 9
- Guide rule
- Dust nozzle
- Plastic carrying case (for **KP0800K**)

**Note:** The standard equipment for the tool shown above may vary by country.

## ► Optional accessories

- |  |                     |                            |
|--|---------------------|----------------------------|
| Planer blade (re-sharpenable type)                       | Guide rules         | Dust bag assembly          |
| T.C.T. Mini planer blade (disposable type)               | Extension guide set | Blade gauge assembly       |
| Set plate (for countries using T.C.T. Mini planer blade) | Dust nozzle         | Sharpening holder assembly |
|  | Elbow               | Plastic carrying case      |

## ► Repair

**CAUTION: Repair the machine in accordance with “Instruction manual” or “Safety instructions”.  
Remove the blades before repair.**

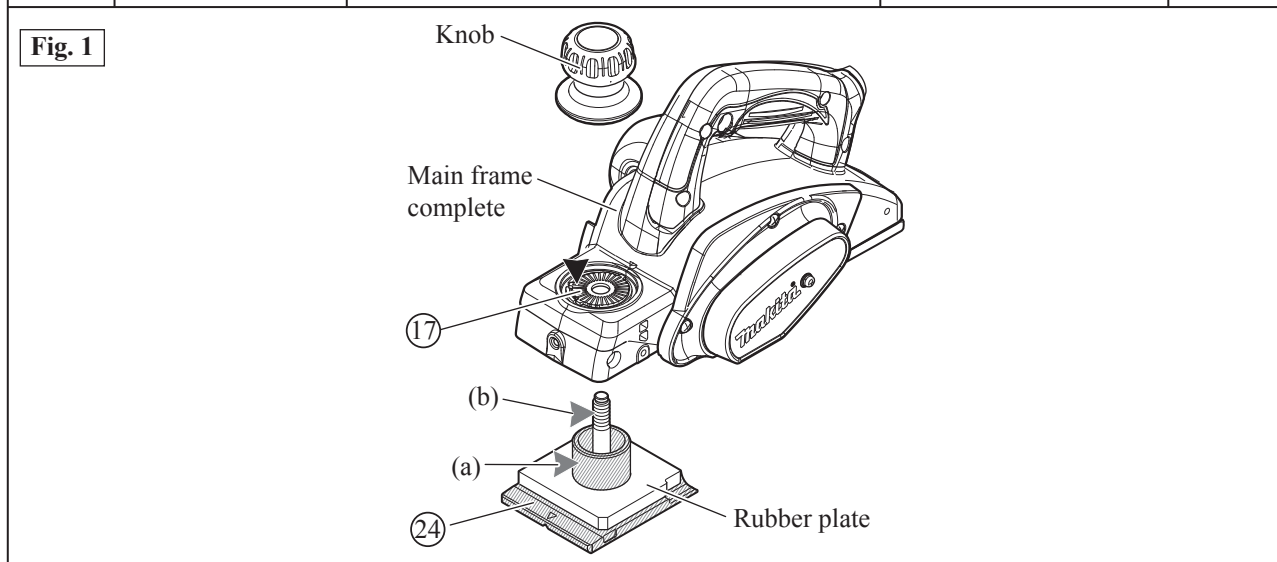
### [1] NECESSARY REPAIRING TOOLS

Code No.	Description	Use for
1R004	Retaining ring pliers ST-2	Removing / mounting Retaining ring S-8
1R045	Gear extractor (large)	Removing Armature from Bracket
1R346	Center attachment	Using with 1R045
1R263	Bearing extractor	Removing Knob cover
1R269	Bearing extractor (small)	Removing Ball bearings

### [2] LUBRICATIONS

Apply the following lubricants to protect parts and product from unusual abrasion.

Item No.	Description	Portion to lubricate	Lubricant	Amount
⑰	Cam plate	The surface where Knob contacts	Makita grease N No.2 ▼	a little
⑳	Front base complete	(a) Cylindric portion where Main frame contacts	VG100 ▼	
		(b) Thread portion		



### [3] DISASSEMBLY/ASSEMBLY

#### [3]-1. Poly V-belt 4-241

##### DISASSEMBLING

Remove M4x16 Pan head screw and separate Belt cover from Main frame complete.

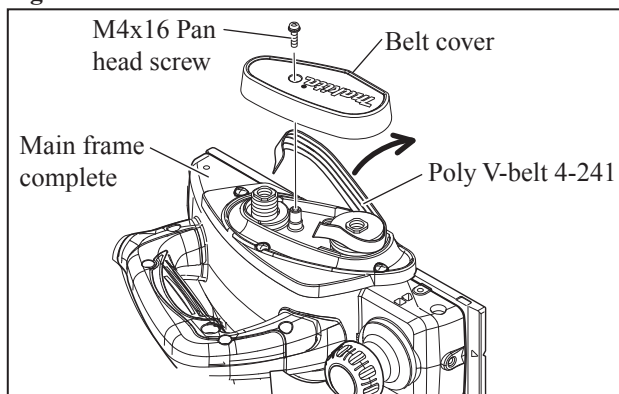
Cut Poly V-belt 4-241 with nippers when it has damaged. (**Fig. 2**)

**Note:** When replacing Armature, Drum and V Pulleys and reusing Poly V-belt 4-241,

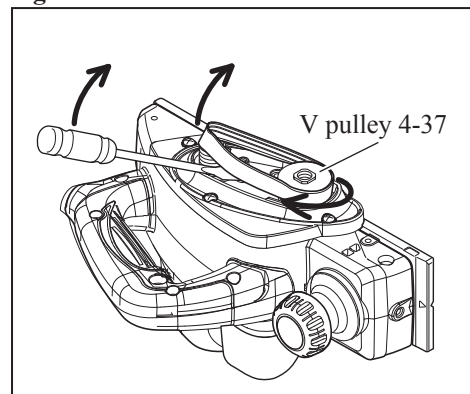
Lever up Poly V-belt 4-241 with screwdriver while turning V pulley 4-37 as illustrated in **Fig. 3**.

Poly V-belt can be removed without cutting.

**Fig. 2**



**Fig. 3**



## ► Repair

### [3] DISASSEMBLY/ASSEMBLY

#### [3]-1. Poly V-belt 4-241 (cont.)

##### ASSEMBLING

- 1) Hook Poly V-belt 4-241 with V-pulley 4-20L. (Fig. 4 ①)
- 2) Hook a part of Poly V-belt with V-pulley 4-37. (Fig. 4 ②)
- 3) Turn V-pulleys 4-20L and 4-37 counterclockwise by hands to fit Poly V-belt to the V-pulleys while holding Poly V-belt firmly. (Fig. 4 ③)

**Note:** If it is difficult to completely fit Poly V-belt to V-pulleys, continue turning V-pulleys until all the grooves are engaged with the protrusions of V-belt. (Fig. 5)

Fig. 4

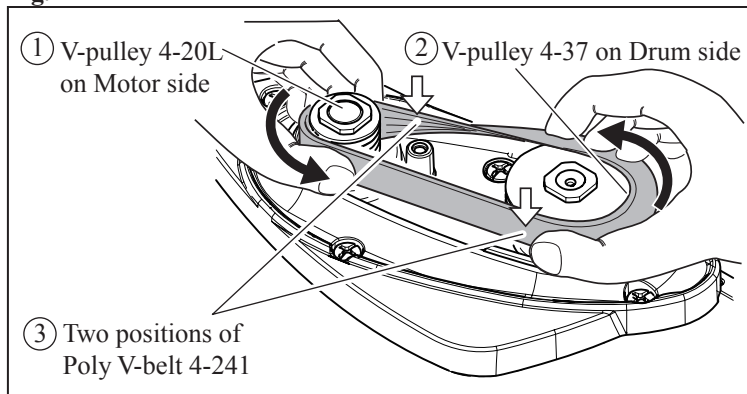
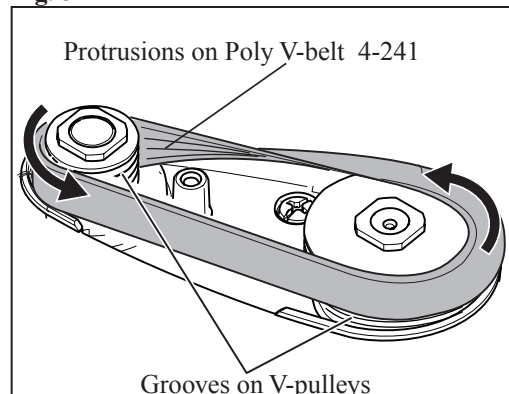


Fig. 5



#### [3]-2. Motor section

##### DISASSEMBLING

- 1) Remove Belt cover and Poly V-belt 4-241 as illustrated in Fig. 2 or Fig. 3.
- Note:** Separating Armature from Bracket is impossible without removing Poly V-belt.
- 2) Loosen M4x16 Pan head screw and remove Chip cover. (Fig. 6)
- 3) Remove Brush holder caps and Carbon brushes, then remove four 4x18 Tapping screw on Bracket. (Fig. 7)
- 4) Remove Bracket by tapping Main frame complete. (Fig. 8) Armature and Drum complete come with Bracket.
- 5) Hold Armature by gloved hand and turn V-pulley 4-20L clockwise using wrench 13. (Fig. 9)

V-pulley 4-20L can be removed.

**Note:** V-pulley 4-20L has a left hand thread.

Fig. 6

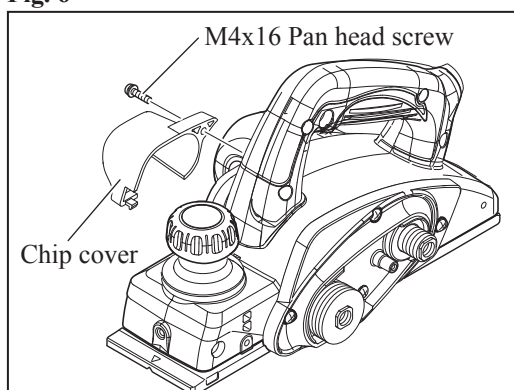


Fig. 7

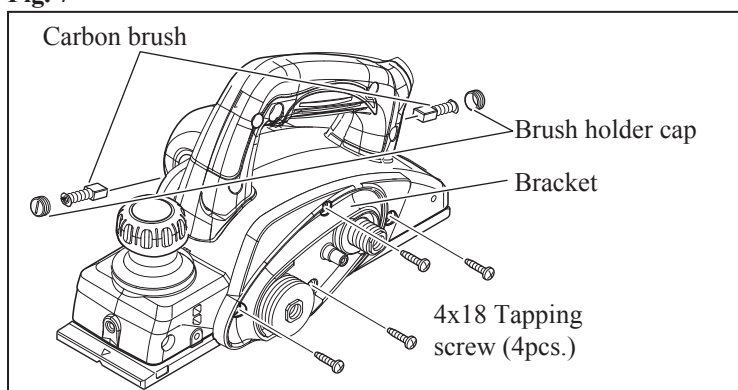


Fig. 8

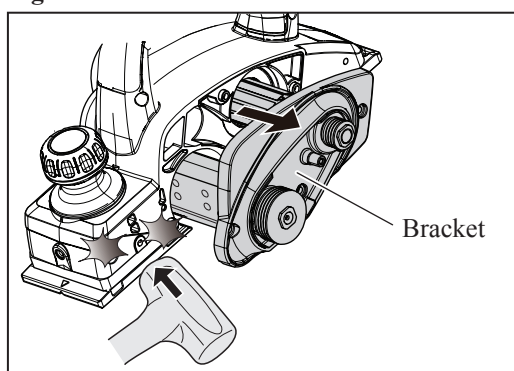
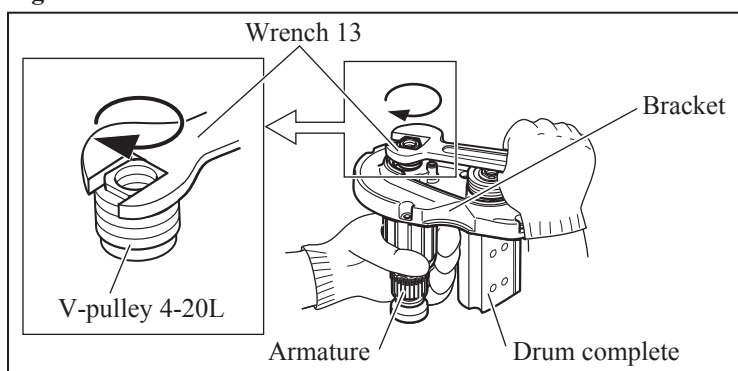


Fig. 9



## ► Repair

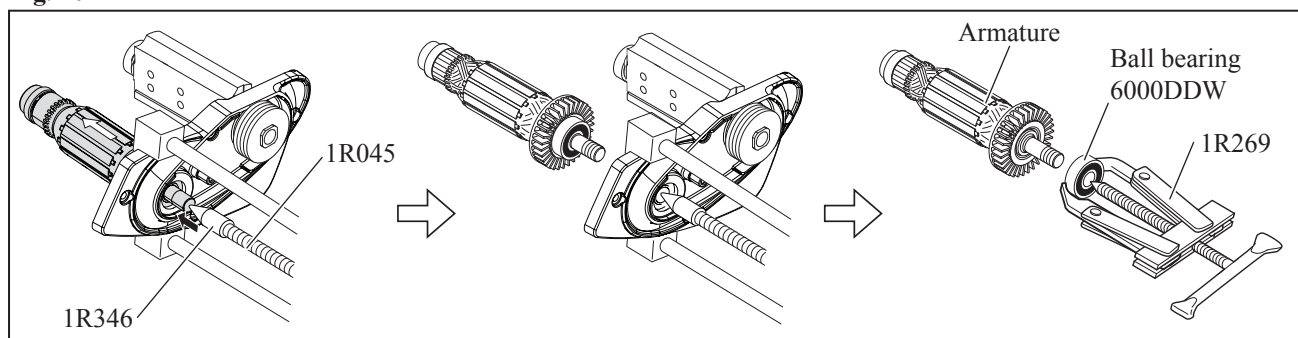
### [3] DISASSEMBLY/ASSEMBLY

#### [3]-2. Motor section (cont.)

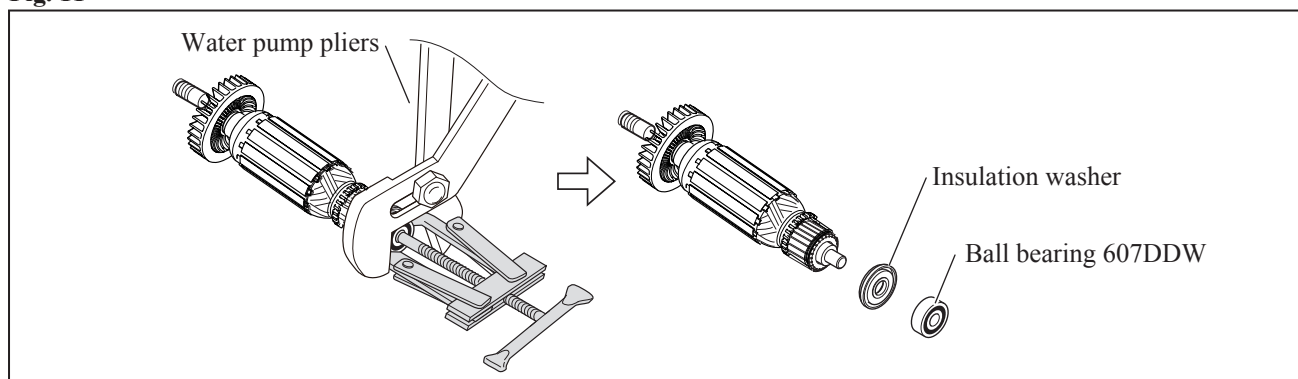
##### DISASSEMBLING

- 6) Remove Armature from Bracket using 1R045 with 1R346. Then remove Ball bearing 6000DDW with 1R269. (**Fig. 10**)
- 7) There are few clearance between Insulation washer and Ball bearing 607DDW. Therefore, it is hard to insert the jaws of 1R269.  
Remove Ball bearing 607DDW and Insulation washer while holding the jaws of 1R269 using water pump pliers. (**Fig. 11**)

**Fig. 10**



**Fig. 11**



##### ASSEMBLING

Take the disassembling step in reverse.

**Note:** When assembling V-pulley 4-20L to Armature shaft using Wrench 13, it is not necessary to tighten the V-pulley to very high torque.

Driving of Poly V-belt 4-241 prevents V-pulley 4-20L from being loose.

## ► Repair

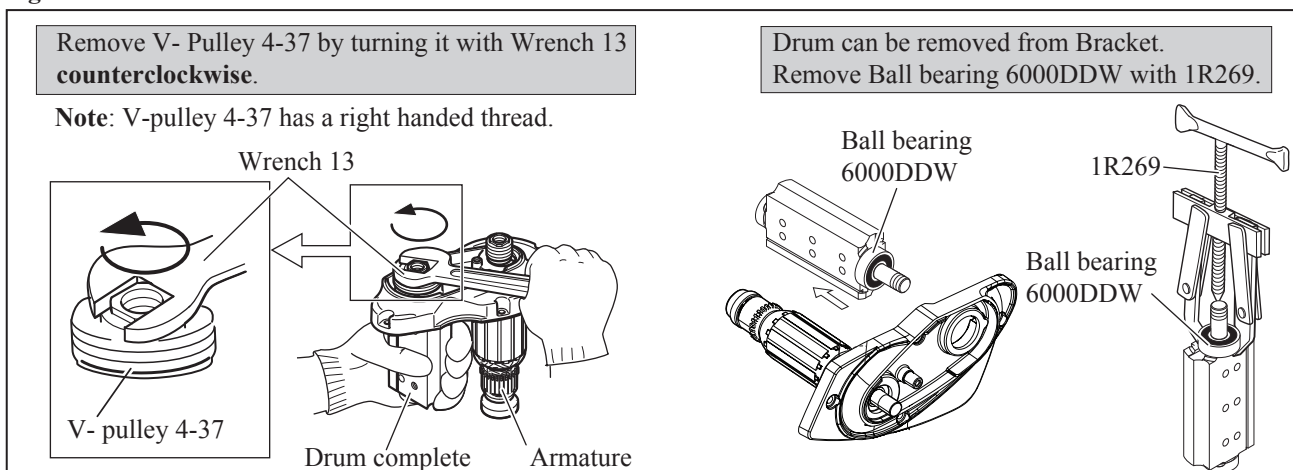
### [3] DISASSEMBLY/ASSEMBLY

#### [3]-3. Drum section

##### DISASSEMBLING

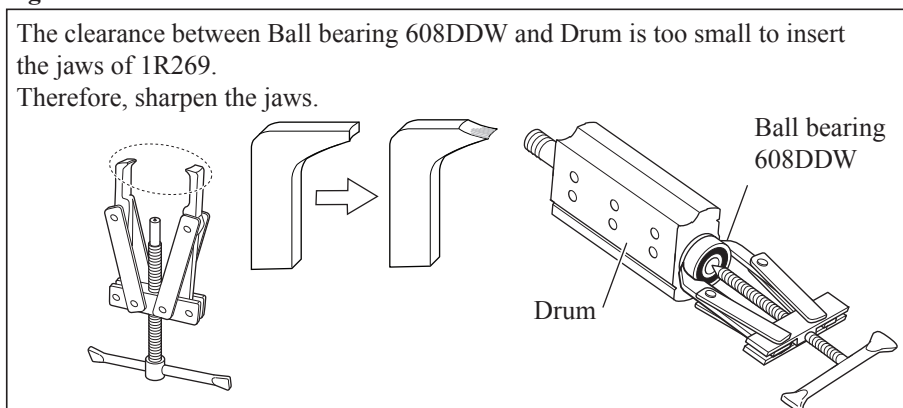
- (1) Remove Chip cover and Carbon brushes, and separate Bracket from Main frame complete.
- (2) Remove V Pulley 4-37, then separate Drum from Bracket as illustrated in **Fig. 12**.

**Fig. 12**

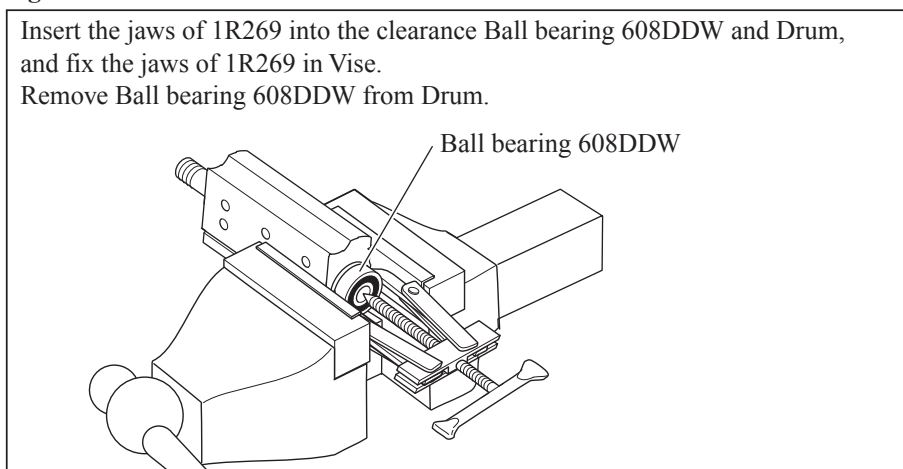


- (3) Remove Ball bearing 608DDW with 1R269 as illustrated in **Figs. 13 and 14**.

**Fig. 13**



**Fig. 14**



##### ASSEMBLING

Take the disassembling step in reverse. Refer to **Figs. 14, 13 and 12**.

Take the disassembling step in reverse.

**Note:** When assembling V-pulley 4-37 to Drum using Wrench 13, it is not necessary to tighten the V-pulley to very high torque.

Reaction torque caused by stopping the rotation prevents V-pulley 4-37 from being loose.



► **Repair**

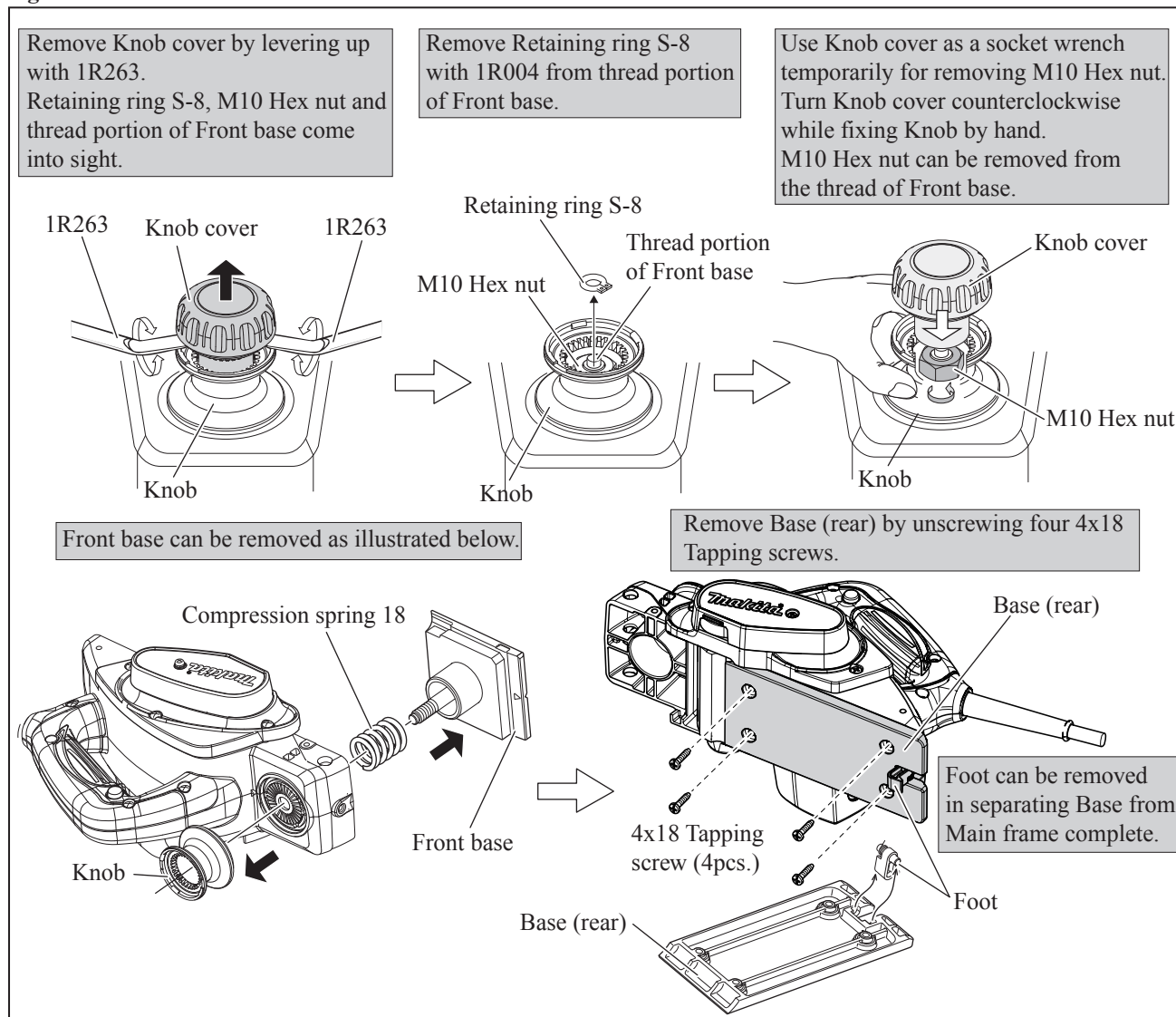
**[3] DISASSEMBLY/ASSEMBLY**

**[3]-3. Front base, Base (rear)**

**DISASSEMBLING**

(1) Front base and Base (rear) can be removed as illustrated in **Fig. 15**.

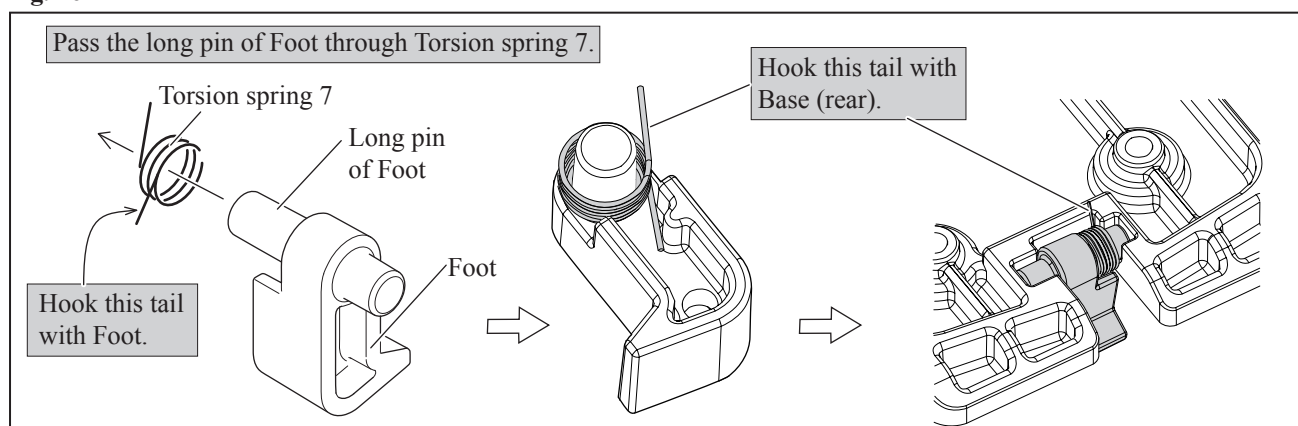
**Fig. 15**



**ASSEMBLING**

- 1) Assemble Foot to Base (rear) before assembling Base to Main frame as illustrated in **Fig. 16**.
- 2) Assemble the Base with Foot to Main frame. And assemble Front base section to Main frame complete. No need to assemble retaining ring S-8 to thread portion of Front base in this step. Refer to **Fig. 15**.

**Fig. 16**



► **Repair**

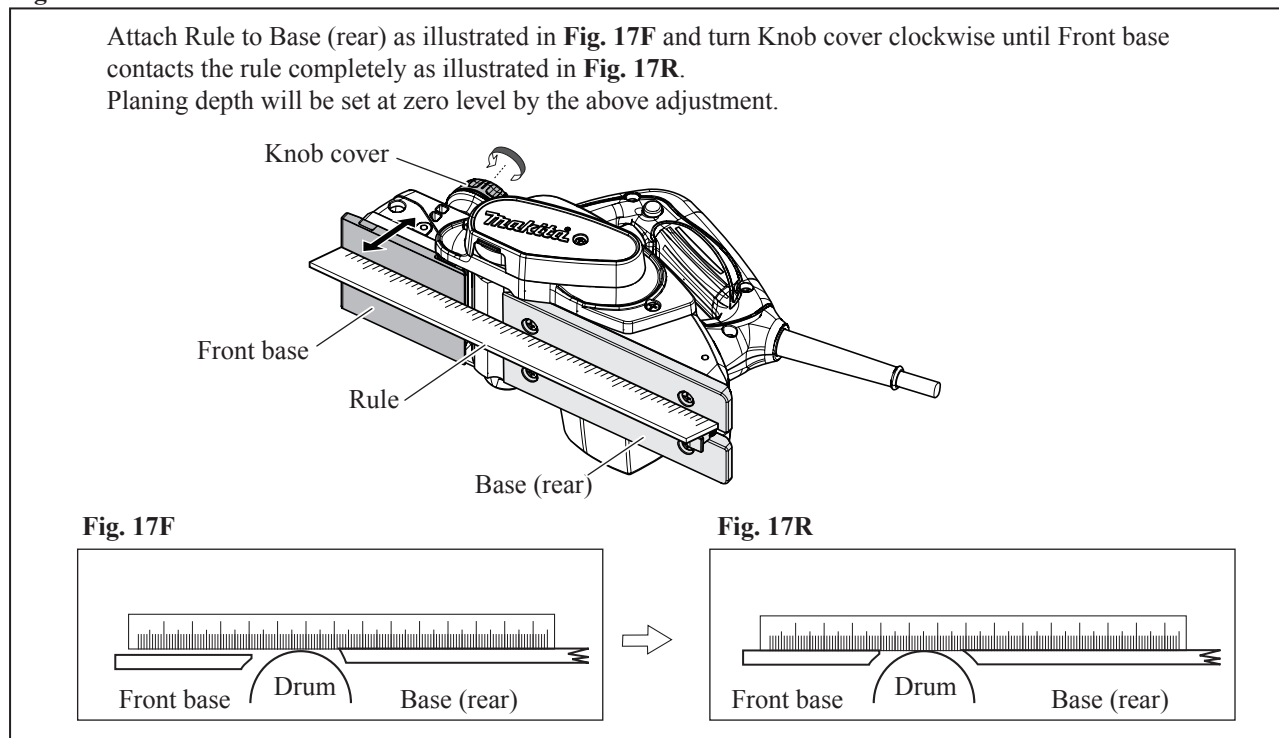
**[3] DISASSEMBLY/ASSEMBLY**

**[3]-3. Front Base, Base (rear)**

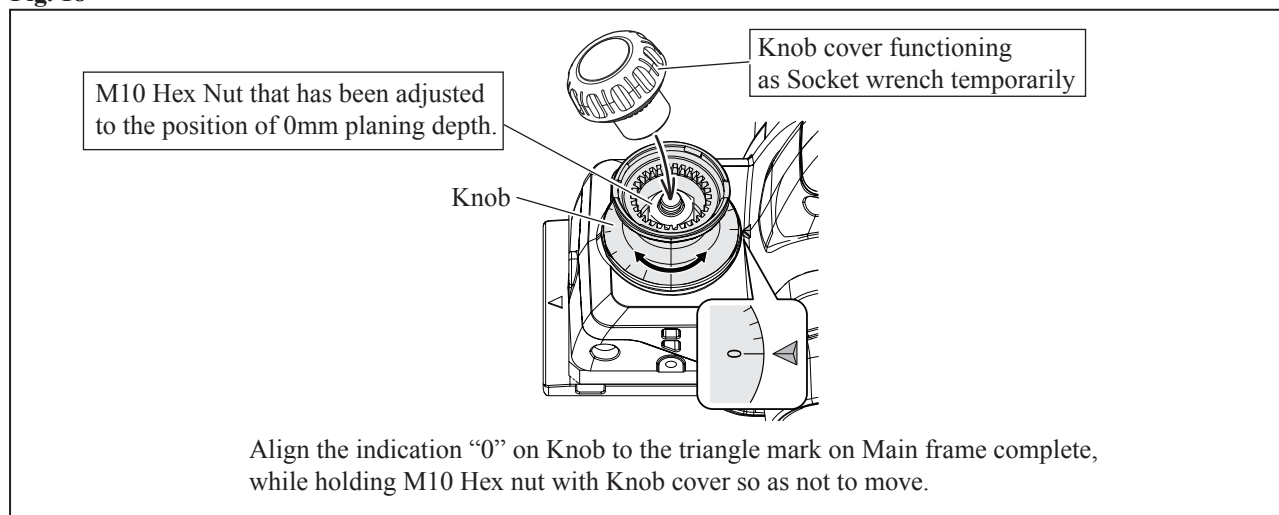
**ASSEMBLING**

3) Adjust the level of Bases as illustrated in **Figs. 17 and 18.**

**Fig. 17**

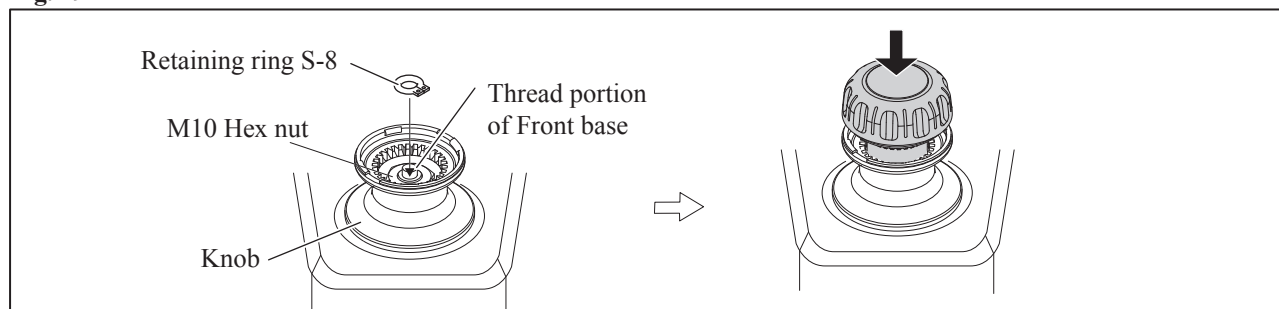


**Fig. 18**



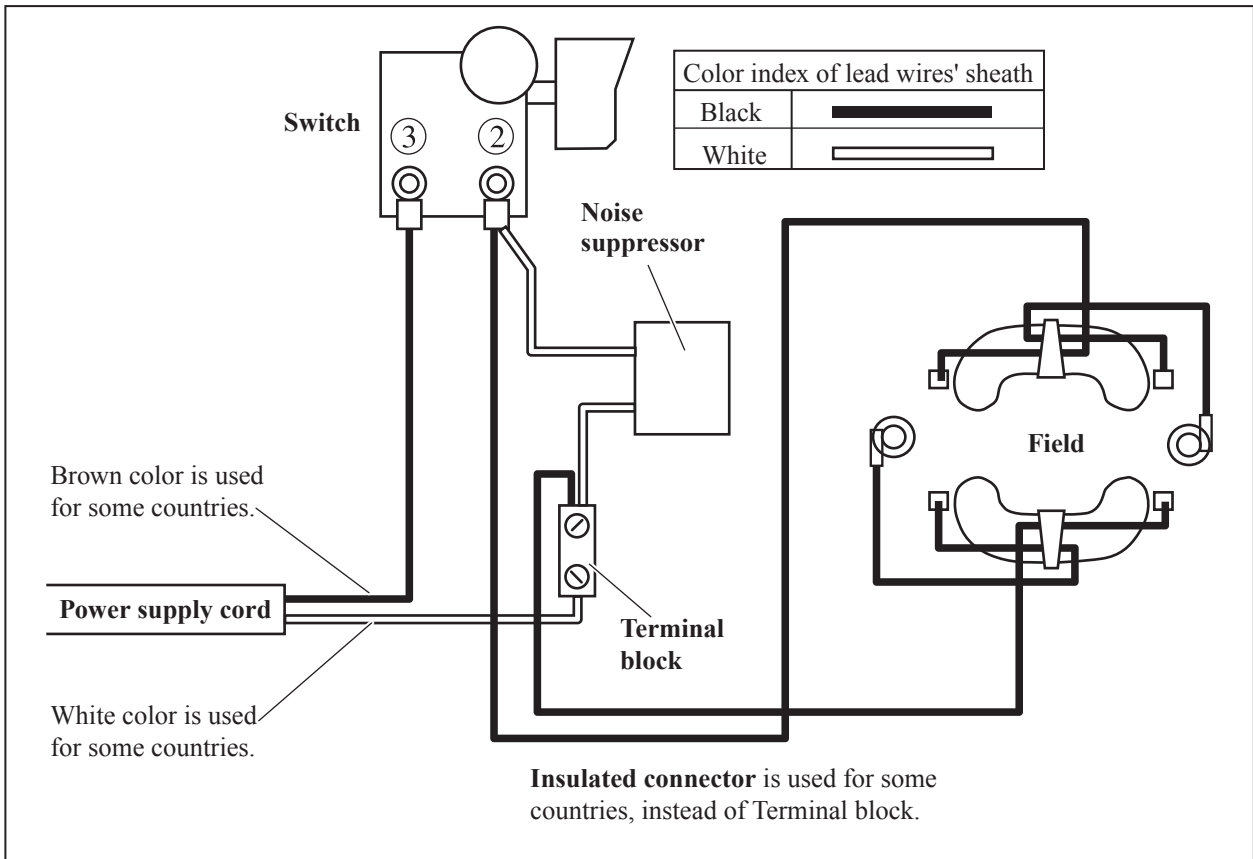
(4) Set Retaining ring S-8 in place. And install Knob cover by pressing to Knob as illustrated in **Fig. 19.**

**Fig. 19**



► **Circuit diagram**

Fig. D-1



► **Wiring diagram**

Fig. D-2

