

TECHNICAL INFORMATION



PRODUCT

P 1 / 12

Models No. ▶ JR3050T

Description ▶ Recipro Saw

CONCEPT AND MAIN APPLICATIONS

Model JR3050T has been developed as a successor model of Model JR3000V/VT, featuring the following main advantages;

1. Cutting efficiency higher than competitions and the predecessor models of Makita reciprocating saws.
2. Great convenience provided by;
 - *Tool-less blade change
 - *Tool-less adjustable heavy duty shoe

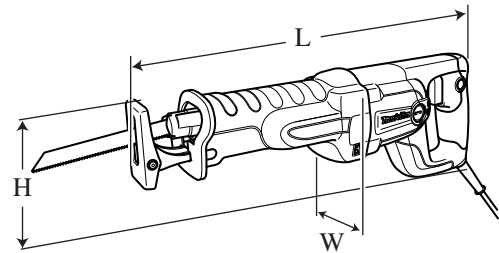

Dimensions: mm (")	
Length (L)	452 (17-3/4)
Width (W)	97 (3-13/16)
Height (H)	170 (6-11/16)

▶ Specification

Voltage (V)	Current (A)	Cycle (Hz)	Continuous Rating (W)		Max. Output(W)
			Input	Output	
110	9.0	50 / 60	940	390	950
120	9.0	50 / 60	1,010	460	950
220	4.8	50 / 60	1,010	550	950
230	4.6	50 / 60	1,010	550	950
240	4.4	50 / 60	1,010	550	950

Stroke per minute: min-1	0 - 2,800	
Length of Stroke: mm (")	28 (1-1/8)	
Capacity	*Wood: mm (")	255 (10)
	Pipe: dia. mm (")	130 (5-1/8)
Variable speed control	Yes	
Net weight: kg (lbs)	3.2 (7.1)	
Power supply cord: m (ft)	Europe: 4.0 (13.1) Australia: 2.0 (6.6) Other countries: 2.5 (8.2)	

*when cutting with the supplied 300mm (11-3/4") length reciprocating saw blade.

▶ Standard equipment

For North America:

Recipro saw blade for steel 1
Recipro saw blade for composites..... 1

For countries other than North America:

Recipro saw blade No.21 for steel 1
Recipro saw blade No.22 for steel 1
Recipro saw blade No.23 for wood and plywood 1

Note: The standard equipment for the tool shown above may differ by country.

▶ Optional accessories

Recipro saw blade No.21 for steel
Recipro saw blade No.22 for steel
Recipro saw blade No.24 for steel

Recipro saw blade No.23 for wood and plywood
Recipro saw blade No.23B for wood and plywood

► Repair

CAUTION: Remove the saw blade from the machine for safety before repair/ maintenance !

[1] NECESSARY REPAIRING TOOLS

Code No.	Descriptions	Purpose
1R291	Retaining ring S and R Pliers	Installing/removing Retaining rings S-18 and S-12
---	Recipro saw blade	Setting Pin 3 (of the blade clamp section) in place
1R250	Round bar for arbor 26-100	Press-fitting Oil seal 14
1R327	Torx screwdriver T25H120	Installing/removing Torx countersunk head screw
1R314	Torx bit VT-25	Installing/removing Torx countersunk head screw
1R232	Pipe 30	Installing/removing Needle bearing 1216
1R245	Round bar for arbor 16-100	Installing/removing Needle bearing 1216
1R269	Bearing extractor (small)	Removing Ball bearing 6001DDW

[2] LUBRICATION AND ADHESIVE

See Fig. 1 below.

Lubrication: Apply Makita Grease N. No.1 to the portions designated with the mark of ▼.

Adhesive: Apply Threebond 1321B/1342 or Loctite 242 to the portions designated with the mark of ▽.

Item No.	Part description	Where to lubricate or apply adhesive
[Lubrication]		
6	Shoulder pin 5	The surface which contacts the hole on Guide sleeve
18	Gear housing cover	The portion where Slider reciprocates
29	Slider	The portion where Plane bearings contact when Slider reciprocates
39	Flat washer 18	The portion where Gear complete contacts
47	Gear housing	The portion where Gear complete and Armature gear rotate Pin 12 to which Needle bearing 1216 is assembled
[Adhesive]		
28, 32	Four M5x16 Pan head screws	Threaded portion (in order to prevent Plates from loosening)
33, 35	Four M5x14 Torx countersunk head screws	Threaded portion (in order to prevent Gear plates from loosening)
46	Three M5x10 Pan head screws	Threaded portion (in order to prevent Bearing retainer from loosening)

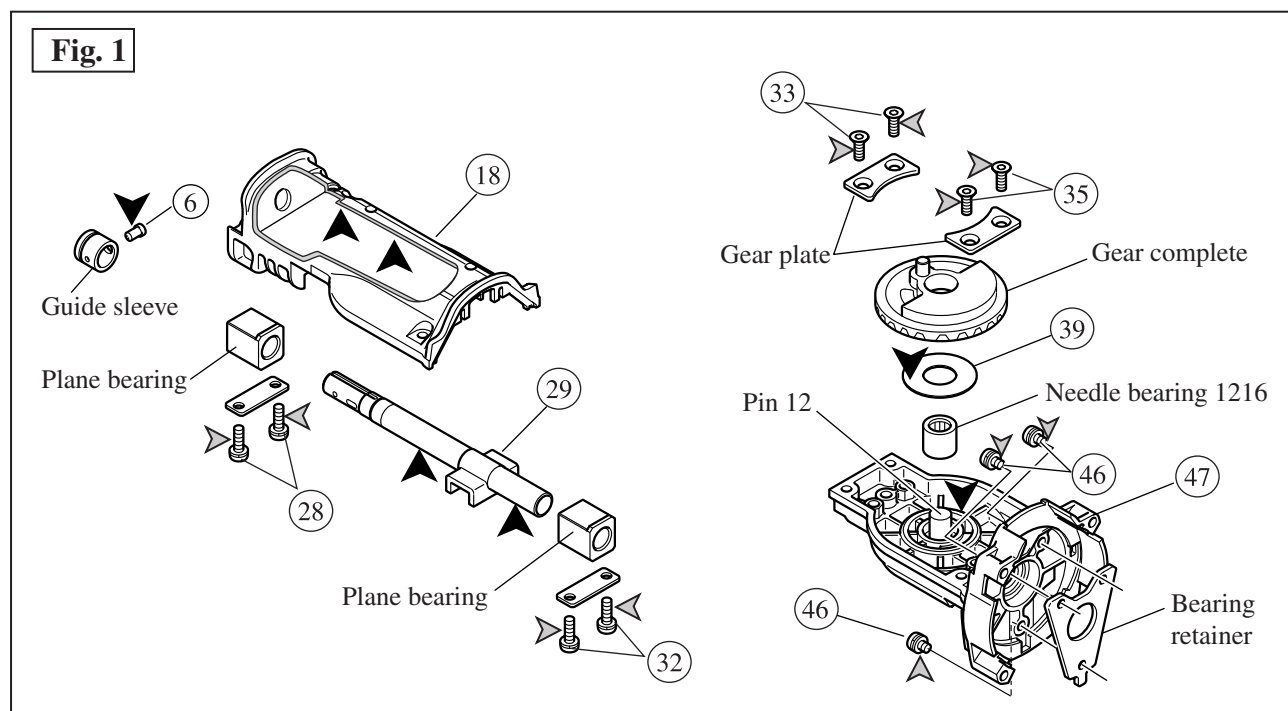

► **Repair**

[3] DISASSEMBLY/ASSEMBLY

[3] -1. Disassembling/ Assembling Blade Clamp Section

DISASSEMBLING

- 1) Remove shoe. If the blade clamp section is positioned inside gear housing, pull it out of gear housing. (Fig. 2)
- 2) After removing protector, remove retaining ring S-18 with Retaining Ring S and R Pliers (No.1R291).
Then remove the following parts:
Driving sleeve, Shoulder pin 5, Compression spring 6,
Pin 3 (of 6mm length), Guide sleeve, Driving sleeve guide
Now sleeve appears. (Fig. 3)

Fig. 2

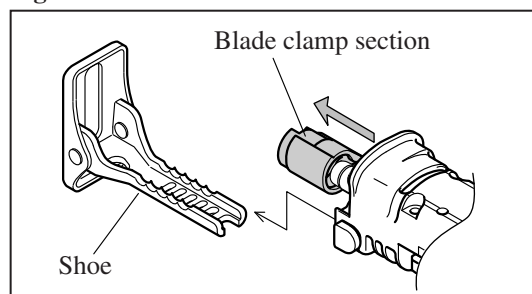
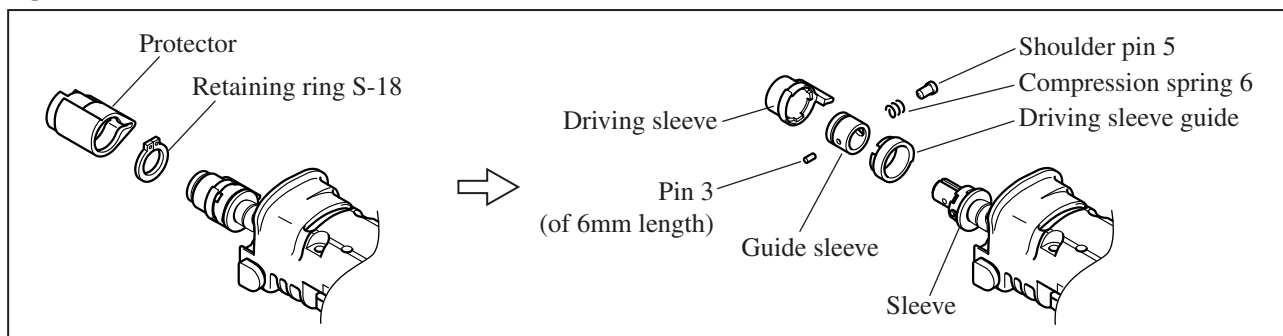
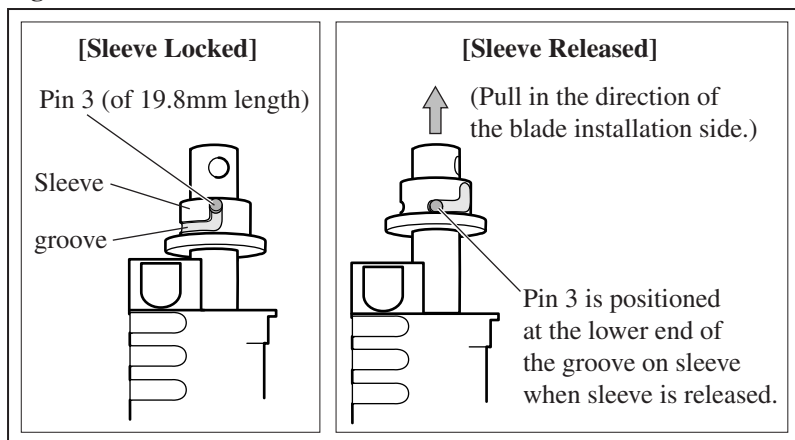

Fig. 3



- 3) Because sleeve is locked, release it by pulling in the direction of the blade installation side. (Fig. 4)

Fig. 4



- 4) While putting your finger on the top of slider to close the slit of slider, remove pin 3 (of 19.8mm length) by pushing with a thin bar. (Fig. 5)

Note: Be sure to put your finger on the top of slider or push plate will pop out from the slit of slider.

- 5) Remove sleeve and torsion spring 17 from slider, then take push plate and compression spring 2 out of the slit of slider. (Fig. 6)

Fig. 5

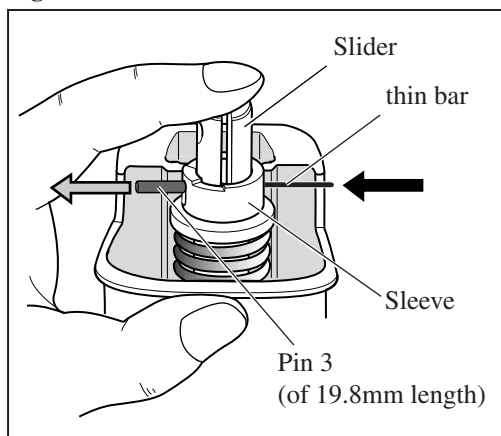
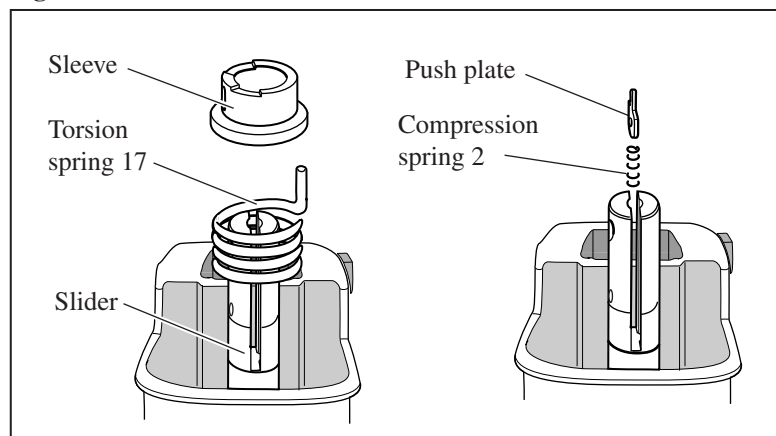

Fig. 6



► Repair

[3] -1. Disassembling/ Assembling Blade Clamp Section (cont.)

ASSEMBLING

1) Assemble torsion spring 17 to slider as illustrated in **Fig. 7**.

Important: Be sure that torsion spring 17 is not reversible when assemble to slider.

Follow the instruction described in **Fig. 7**.

2) Insert compression spring 2 into the slit of slider.

3) Install sleeve on slider and lock pin 3 temporarily by turning sleeve clockwise. (**Fig. 8**)

Fig. 7

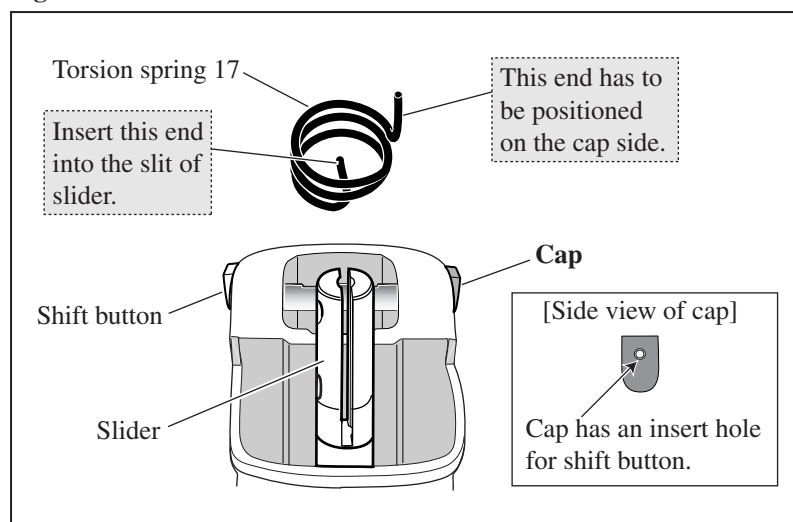
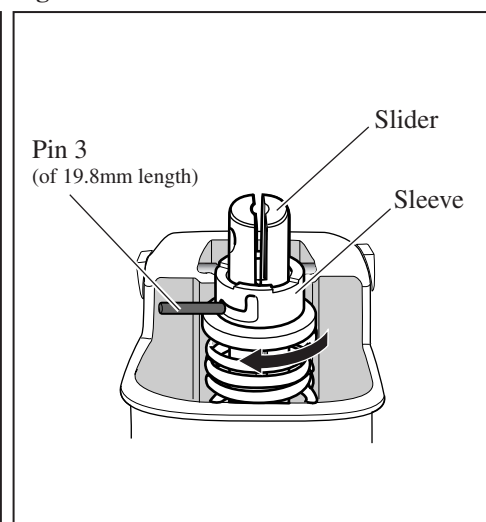

Fig. 8



4) Mount guide sleeve temporarily, and put push plate into the slit of slider as illustrated to left in **Fig. 9**.

Important: Be sure that push plate is not reversible when installed.

While pushing push plate straight into slider with reciprocating saw blade, insert pin 3 (of 19.8mm length) through the hole of push plate as illustrated to right in **Fig. 9**. And then remove guide sleeve.

Note: Guide sleeve is used as a jig, not assembled to slider yet in this step.

Fig. 9

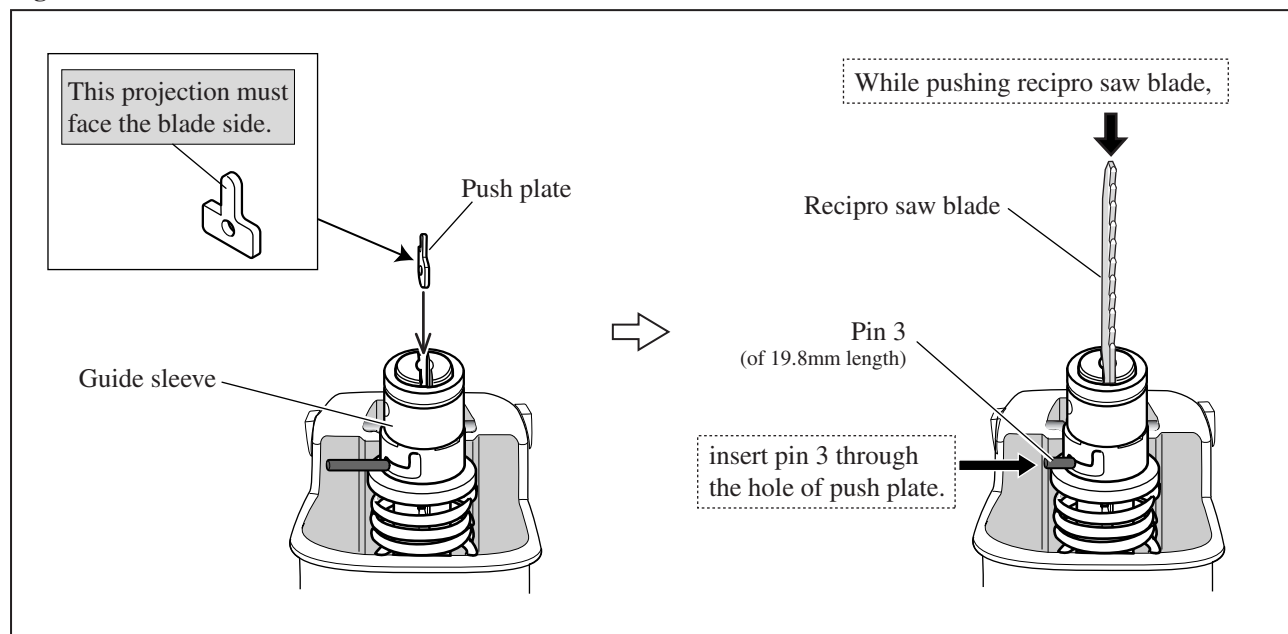

► Repair

[3] -1. Disassembling/ Assembling Blade Clamp Section (cont.)

5) While fitting the two projections of driving sleeve in the concavities of sleeve, push driving sleeve into gear housing housing. At this time, turn driving sleeve clockwise so that the protruding portion of driving sleeve cannot be interfered by gear housing. After driving sleeve is pushed into gear housing to the full, turn driving sleeve clockwise to lock pin 3 in place. (Fig. 10)

Note: Driving sleeve is used as a jig to lock pin 3 in place, not assembled to slider in this step.

6) Remove driving sleeve.

Fig. 10

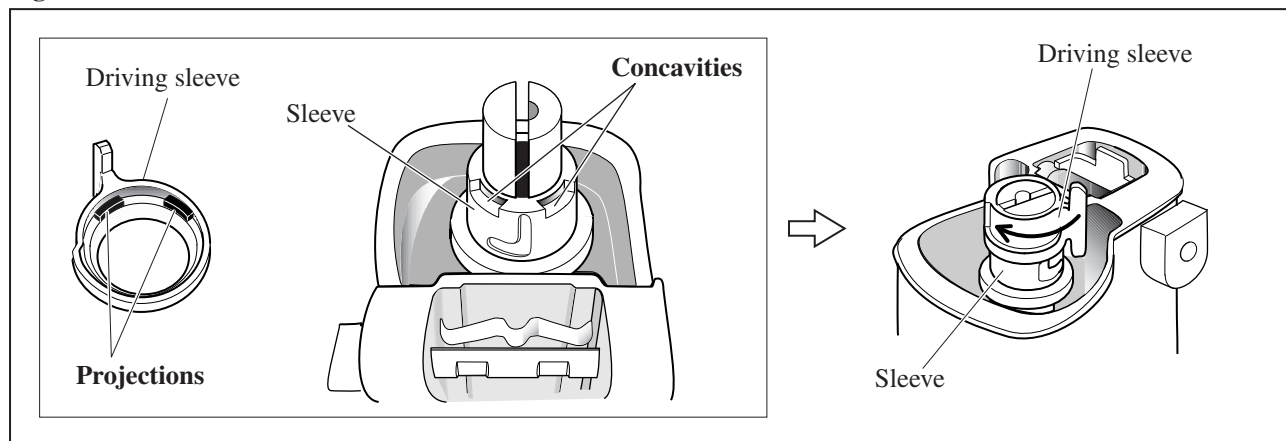

7) Assemble the following parts to slider (Refer to Fig. 3.):

Driving sleeve guide, Guide sleeve, Pin 3 (of 6mm length), Shoulder pin 5, Compression spring 6

8) Put driving sleeve over guide sleeve and secure it with retaining ring S-18 using 1R291. Then cover driving sleeve with protector. (When installing driving sleeve, fit its projections in the concavities of sleeve and driving sleeve guide.)

[3] -2. Replacing Shift Button and Cap

DISASSEMBLING

Shift button can be removed from gear housing cover by inserting a thin bar into the hole of cap and push the bar. (Fig. 11)

Fig. 11

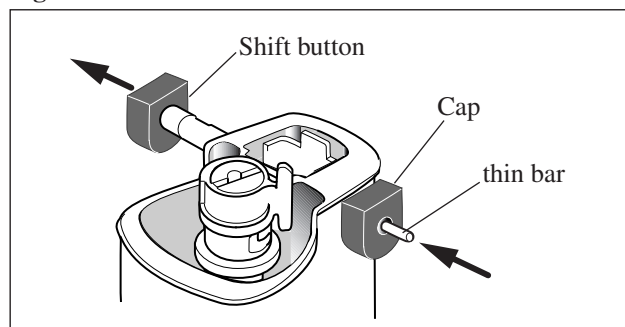

ASSEMBLING

- 1) Replace cap by new one because removal of shift button damages the inside surface of cap.
- 2) From shift button, remove all the plastic dust scraped off the removed cap. Insert shift button through the holes in the both sides of gear housing cover. And then press-fit shift button in the new cap by hand.

Important:

Be sure to assemble shift button to gear housing cover so that the two notches of shift button face the side opposite to slider as illustrated in Fig. 12.

Fig. 12

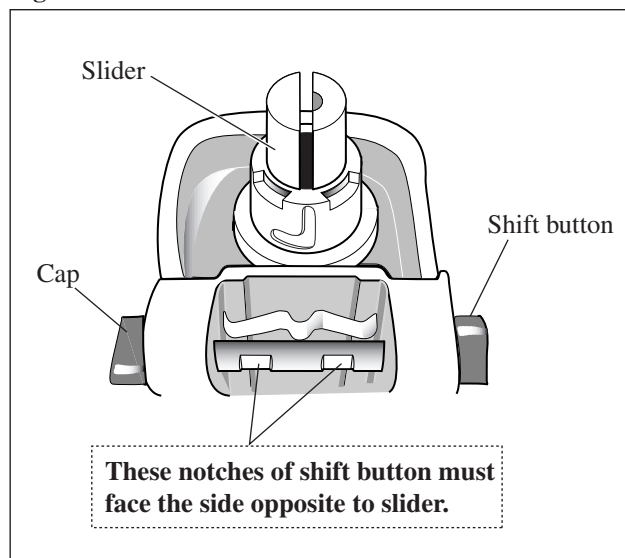

► Repair

[3] -3. Disassembling/ Assembling Slider

DISASSEMBLING

- 1) Remove shoe and insulation cover.
- 2) Remove the blade clamp section. (Refer to [3] -1.)
- 3) Separate gear housing cover from gear housing by removing two M5x25 pan head screws and two M5x35 pan head screws.
- 4) Remove two plates from gear housing cover by unscrewing four M5x16 pan head screws. (**Fig. 13**)
- 5) From slider, remove the plane bearing 14 on the motor housing side.
- 6) Move slider towards the motor housing side. Then remove slider from gear housing cover by pulling in the direction designated by the gray arrow. (**Fig. 14**)

Fig. 13

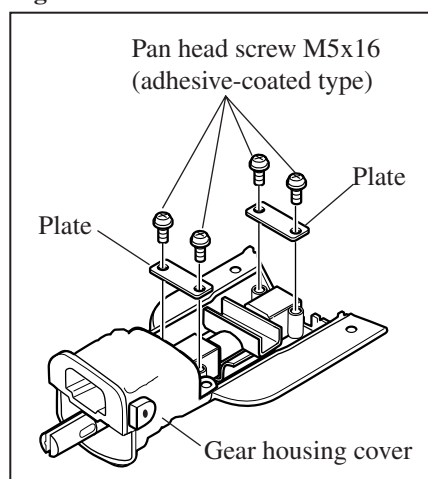
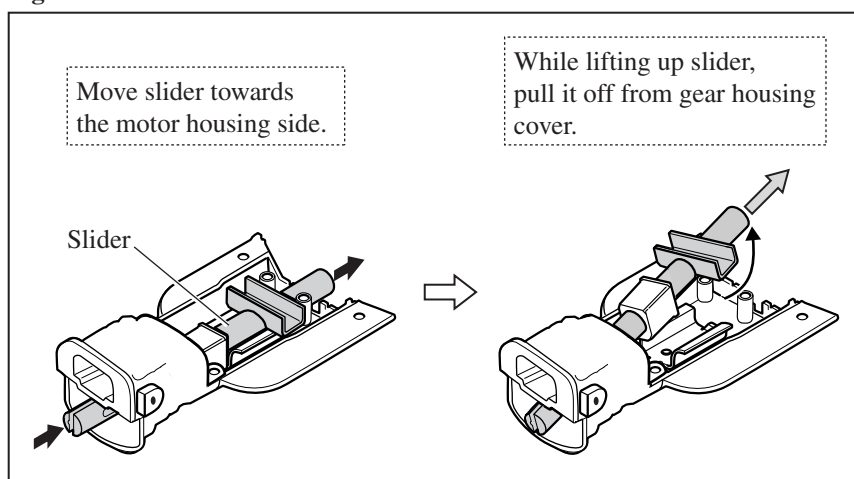

Fig. 14



ASSEMBLING

Do the reverse of the disassembling steps.

Notes:

- 1) Apply Makita grease N No.1 to slider as illustrated in **Fig. 15** in order to lubricate X ring 14 and plane bearings 14.
- 2) Plane bearings 14 are not reversible when assembled to slider. Be sure to install them as illustrated in **Fig. 16**.

Fig. 15

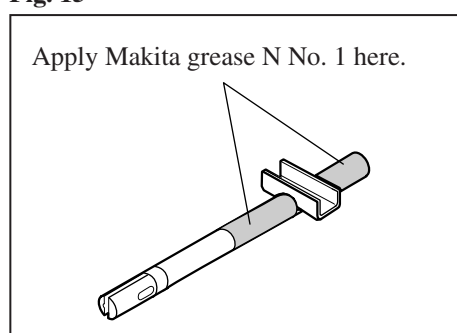
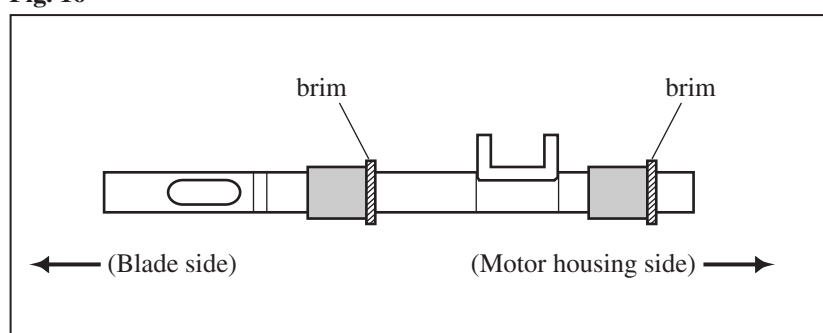

Fig. 16



- 3) Do not forget to install seal ring when assembling gear housing cover to gear housing.

► Repair

[3] -4. Replacing Oil Seal 14 and X Ring 14

DISASSEMBLING

- 1) Separate gear housing cover from gear housing as described in 1) to 3) of [3] -3.
- 2) Remove oil seal 14 by hitting from the motor housing side using slotted screwdriver and plastic hammer. Then remove X ring 14 by pushing with finger. (Fig. 17)

Fig. 17

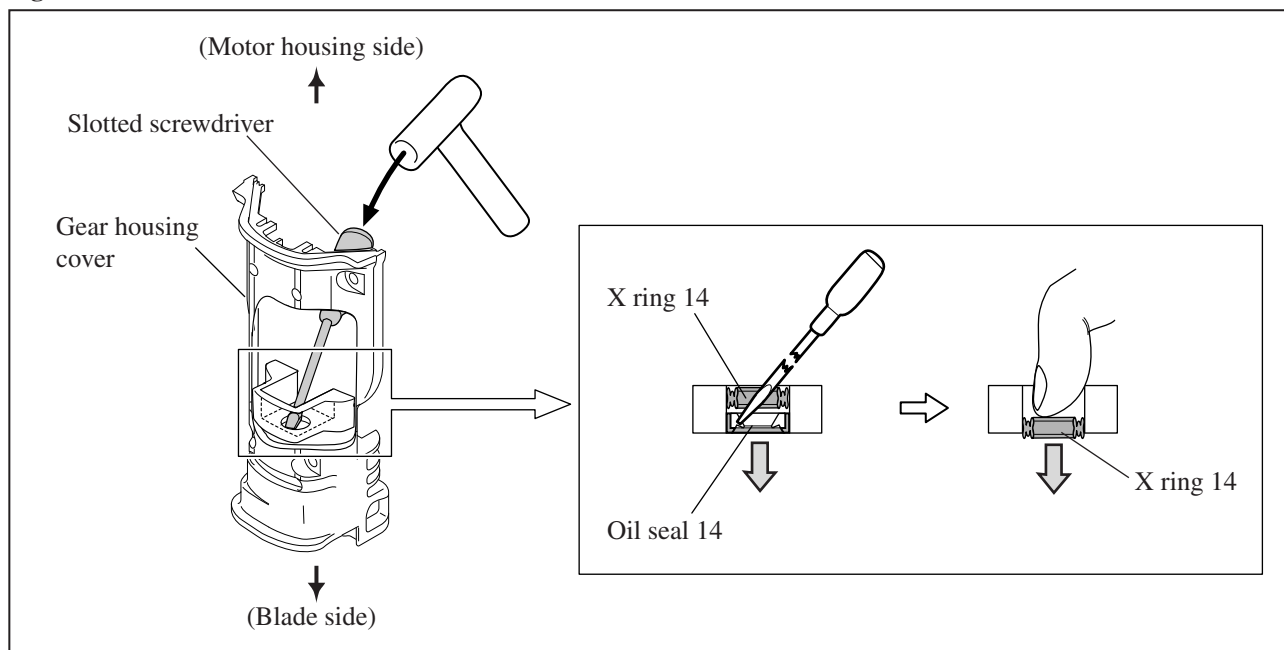

ASSEMBLING

Put X ring 14 in place. And then press-fit oil seal 14 using arbor press and Round bar for arbor 26-100 (No.1R250) as illustrated in Fig. 18.

Important:

1. Oil seal 14 is not reversible when assembled to gear housing cover. Be sure to set it so that the rubber lip faces the blade side as illustrated in Fig. 19.
2. Install oil seal 14 so that it is flush with the surface of gear housing cover. (Fig. 19)
3. Do not reuse the removed oil seal because the rubber lip is damaged when removed from gear housing cover.

Fig. 18

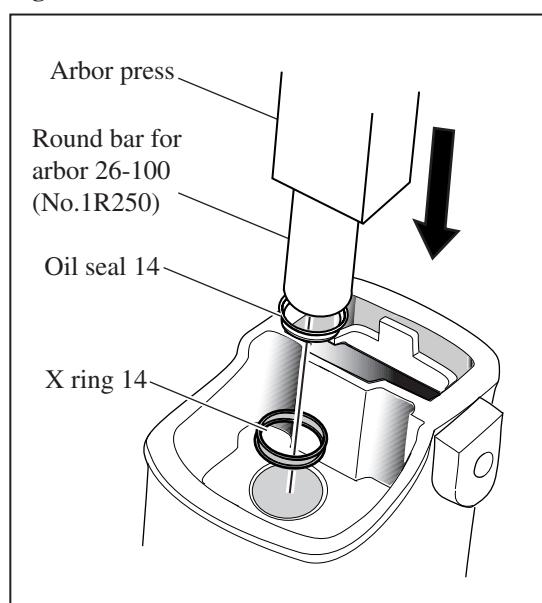
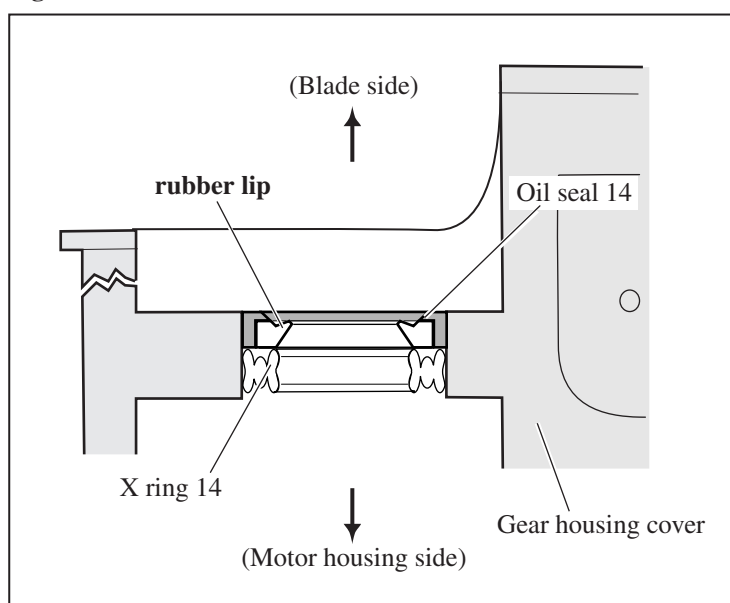

Fig. 19



► Repair

[3] -5. Gear Complete

DISASSEMBLING

- 1) Separate gear housing from gear housing cover as described in 1) to 3) of [3] -3.
- 2) Remove two gear plates from gear housing by unscrewing four M5x14 torx countersunk head screws (adhesive-coated) with Torx bit VT-25 (No.1R314) or Torx screwdriver T25H120 (No.1R327). (**Fig. 20**)
Then remove gear complete from gear housing. (**Fig. 21**)

Fig. 20

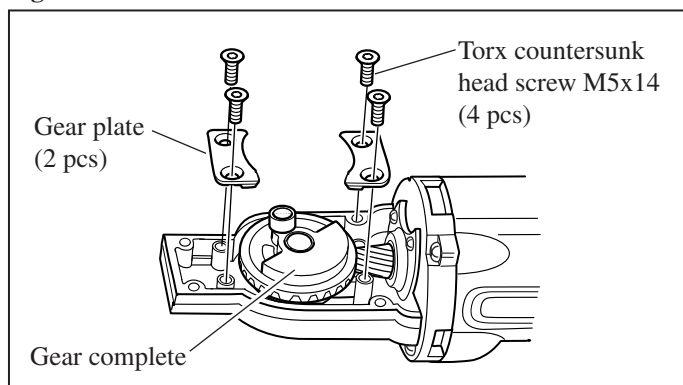
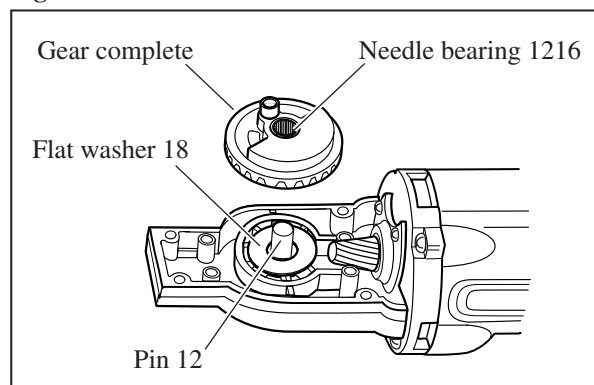

Fig. 21



- 3) Put gear complete on Pipe 30 (No.1R232), and place Round bar for arbor 16-100 (No.1R245) on needle bearing 1216. And press out needle bearing 1216 as illustrated in **Fig. 22**.

ASSEMBLING

Do the reverse of the disassembling steps.

Note:

1. Before assembling gear complete to gear housing, apply about 1g of Makita grease N No.1 to flat washer 18 and pin 12 respectively. (Refer to **Fig. 20**.)
2. Apply adhesive to four M5x14 torx countersunk head screws.

Fig. 22

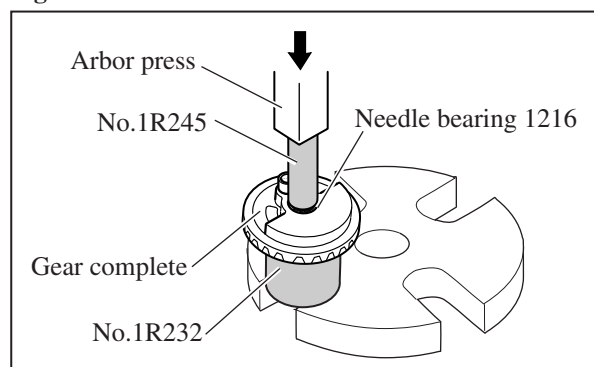

[3] -6. Replacing Armature

- 1) Remove carbon brushes, shoe and insulation cover.
- 2) Remove gear housing cover from gear housing as described in 1) to 3) of [3] -3.
- 3) Separate gear housing from motor housing by unscrewing four M5x35 tapping screws.
- 4) Remove baffle plate from gear housing. then remove armature from gear housing by removing three M5x10 pan head screws (adhesive-coated) with impact driver. (**Fig. 23**)
In this step, ball bearing 6001DDW and bearing retainer are still assembled to armature.

Note: Apply adhesive to three M5x10 pan head screws when assembling.

Fig. 23

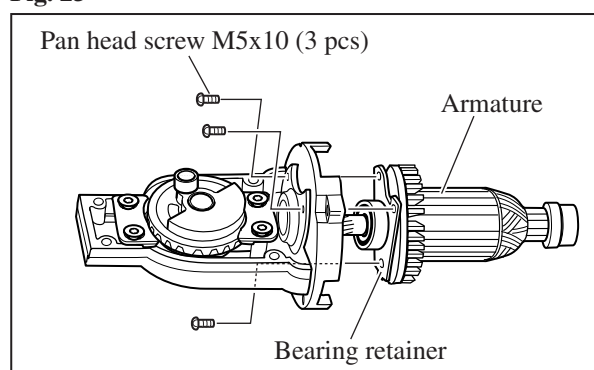

- 5) Remove retaining ring S-12 from armature using Retaining ring S and R pliers (No.1R291), then ball bearing 6001DDW using Bearing extractor (No.1R269). Now bearing retainer can be removed from armature. (**Fig. 24**)

Fig. 24

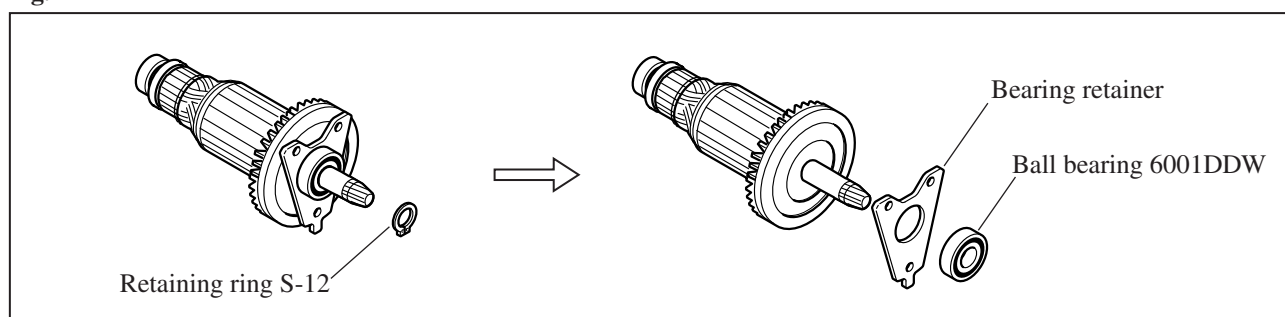

► Circuit diagram

Taiwan, and low voltage of Great Britain

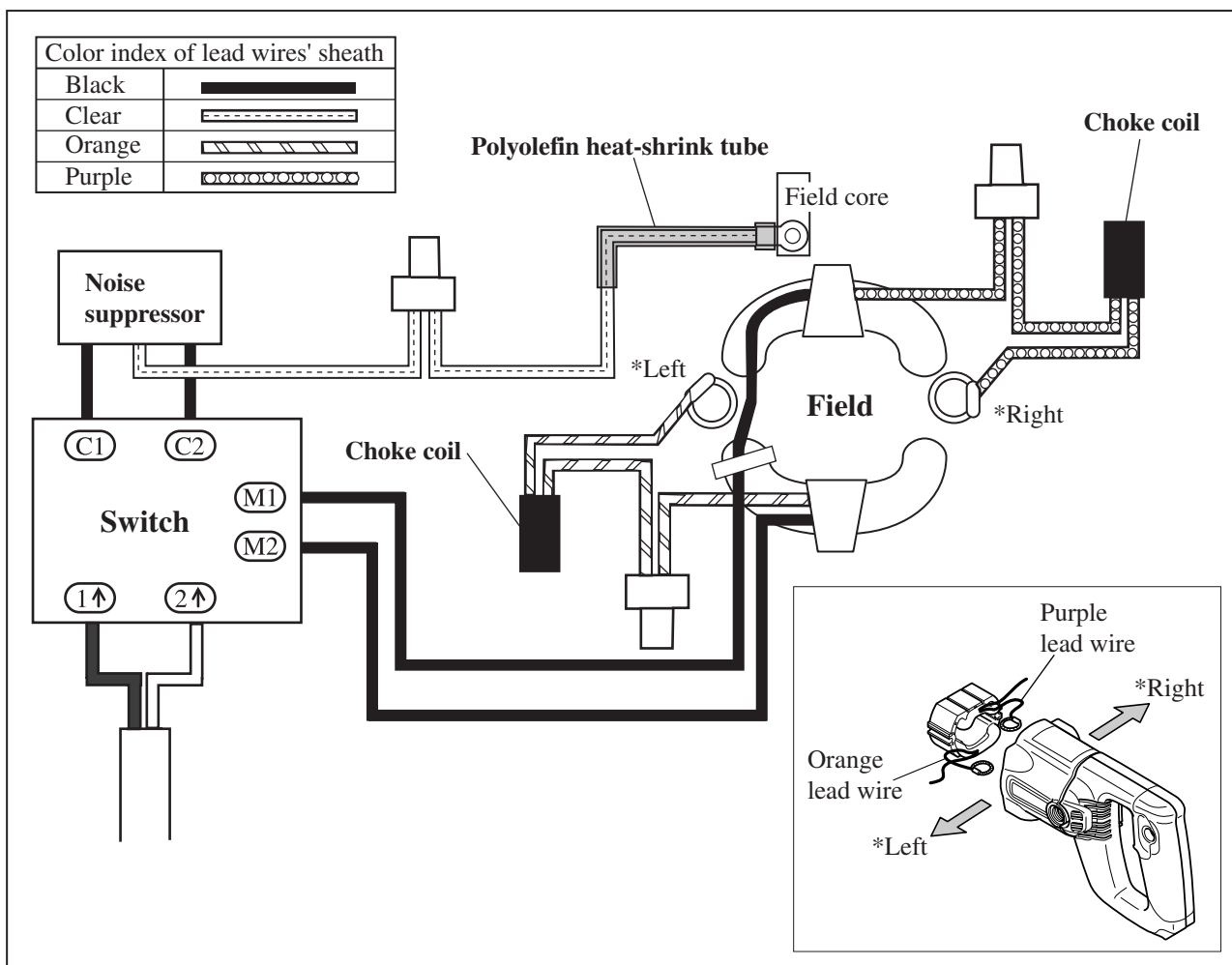

All other countries and areas

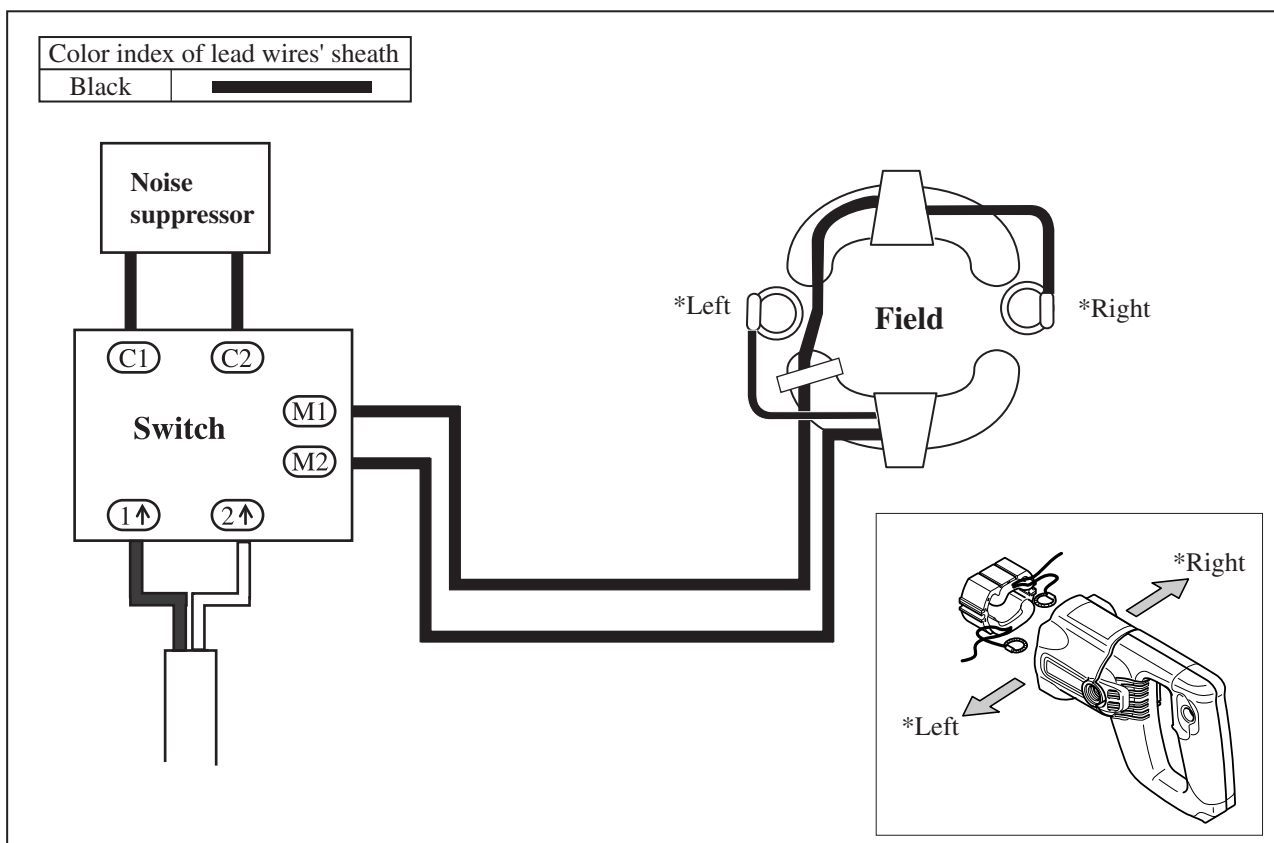

▶ Wiring diagram

[1] Protecting the Interconnecting Lead Wire with Heat-Shrink Tube

In case that noise suppressor is used, protect the lead wire that interconnects between noise suppressor and field core using polyolefin heat-shrink tube. Be sure to cover the crimped portion as illustrated in **Fig. 25**.

Fig. 25

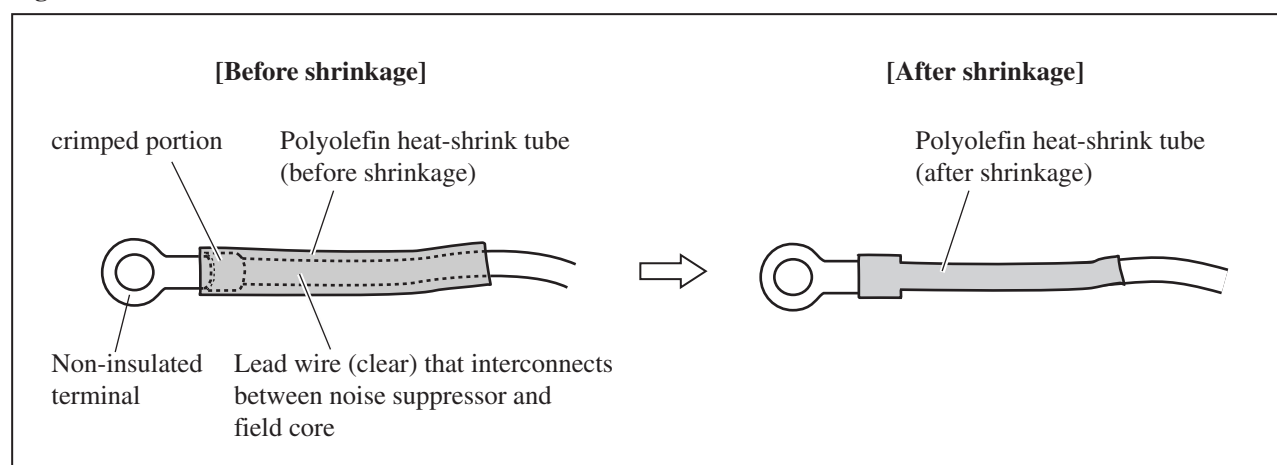

[2] Wiring in Motor Housing

[2] -1. Front Side; Routing the Lead Wire Interconnecting Between Noise Suppressor and Field Core

Fig. 26

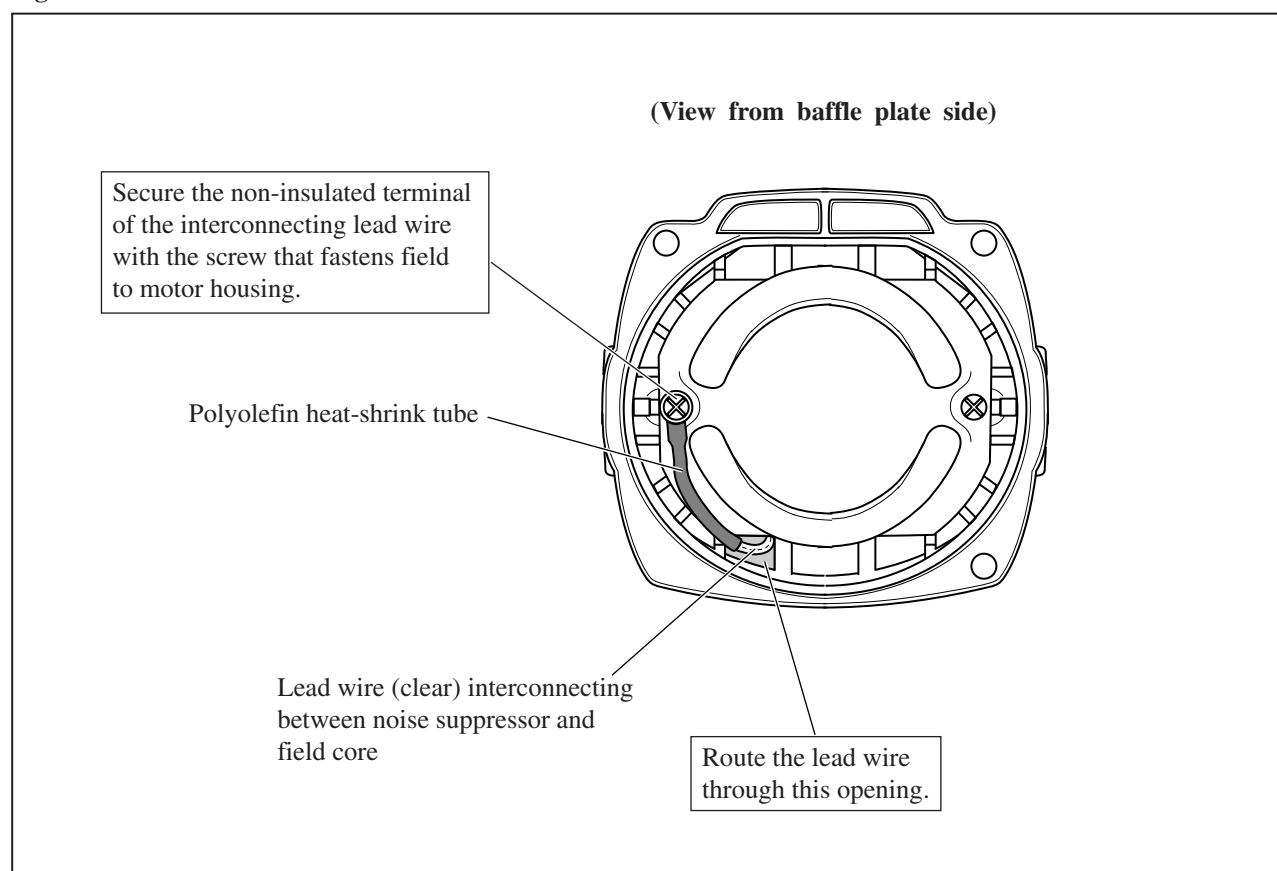

► **Wiring diagram**

[2] Wiring in Motor Housing (cont.)

[2] -2. Rear side

Note: Choke coils are not used except for the following countries:
Taiwan, low voltage of Great Britain

Fig. 27

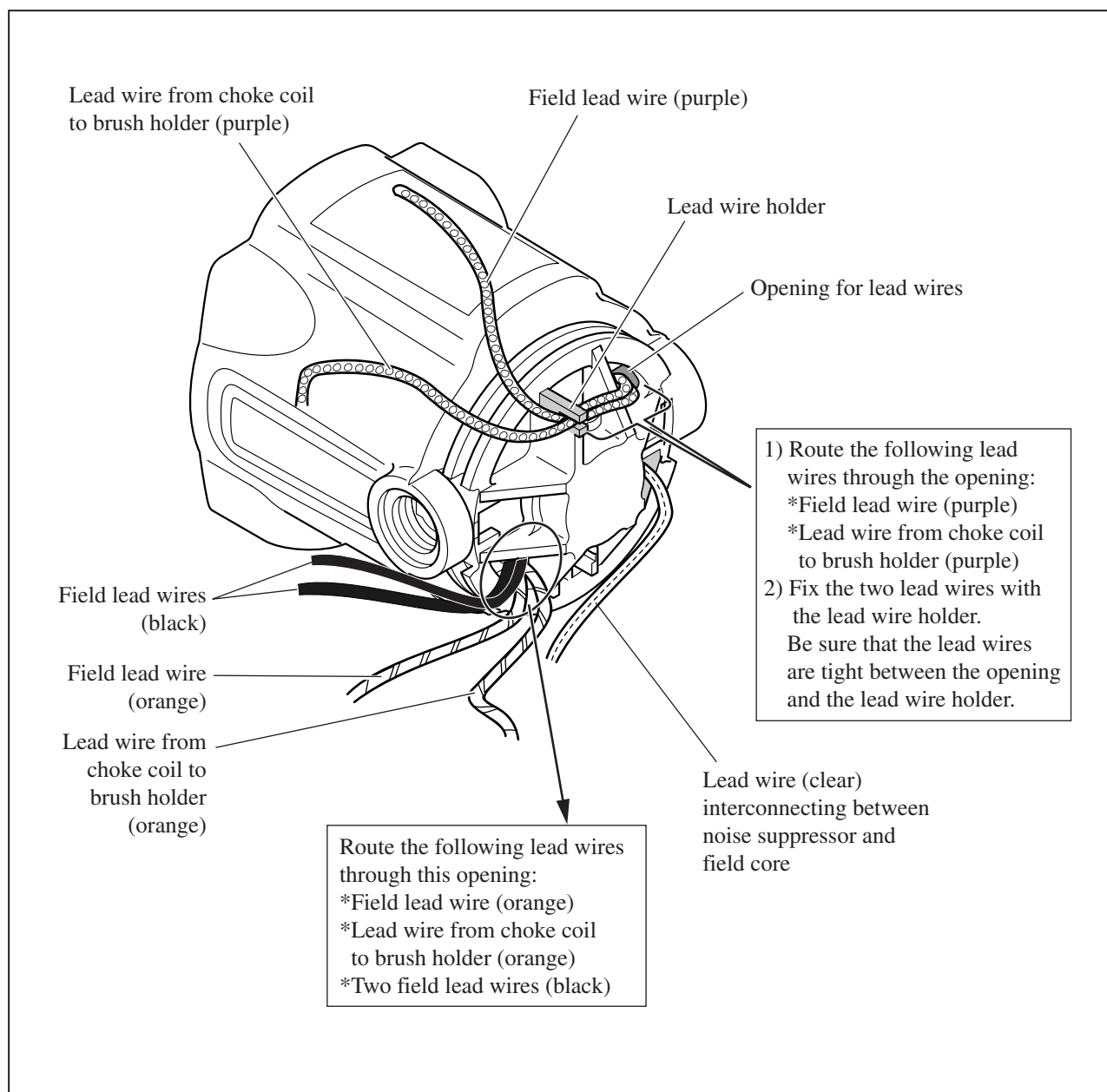

▶ Wiring diagram

[3] Wiring in Handle

Note: Choke coils are not used except for the following countries:
Taiwan, low voltage of Great Britain

