

TECHNICAL INFORMATION



PRODUCT

P 1 / 21

Model No. ▶ HR2230, HR2460, HR2460F
HR2470, HR2470F, HR2470T, HR2470FT

Description ▶ Rotary Hammers 22mm (7/8"), 24mm (15/16")

CONCEPT AND MAIN APPLICATIONS

The subject models are successors to the current models called "2kg Rotary hammer". HR2230, HR2460 and HR2460F have two operation modes (Rotation only / Rotation with hammering).

HR2470, HR2470F, HR2470T and HR2470FT have three operation modes (Rotation only / Rotation with hammering / Hammering only).

The letters of the model name show the features as follows;
HR22 or 24: Capable of drilling 22 or 24 mm diameter hole to concrete

F: Equipped with LED to illuminate the hammering spot
T: Changeable between a chuck for SDS-plus and keyless three-jaw drill chuck quickly without any tool

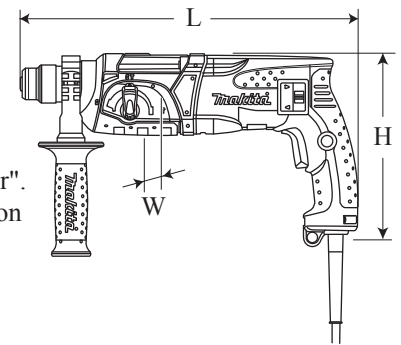

Dimensions: mm (")				
	HR2230	HR2460 HR2460F	HR2470 HR2470F	HR2470T HR2470FT
Length (L)	357 (14)	362 (14-1/4)	370 (14-1/2)	394 (15-1/2)
Width (W)	84 (3-5/16)			
Height (H)	214 (8-3/8)			

Specification

Voltage (V)	Current (A)		Cycle (Hz)	Continuous Rating (W)				Max. Output(W)	
	HR2230	Except HR2230		Input		Output		HR2230	Except HR2230
				HR2230	Except HR2230	HR2230	Except HR2230		
110	6.8	7.5	50 / 60	710	780	350	390	500	550
120	6.2	6.7	50 / 60	—	—	350	390	500	550
220	3.4	3.7	50 / 60	710	780	350	390	500	550
230	3.3	3.6	50 / 60	710	780	350	390	500	550
240	3.1	3.4	50 / 60	710	780	350	390	500	550

Specification		Model	HR2230	HR2460/ HR2460F	HR2470/ HR2470F	HR2470T/ HR2470FT
Continuous rating input: W			710	780		
No load speed: min. ⁻¹ = rpm			0 - 1,050	0 - 1,100		
Impacts per minute= min. ⁻¹			0 - 4,050	0 - 4,500		
Bit shank			Adapted for SDS-PLUS			SDS-plus [Round shank bit is available by replacing quick change chuck for SDS-plus with quick change drill chuck (keyless)]
Operation mode			2 modes (Rotation only/ Rotation with Hammering)		3 modes (Rotation only/ Rotation with Hammering/ Hammering only)	
Capacity: mm (")	Concrete		22(7/8)	24 (15/16)		
	Steel		13 (1/2)			
	Wood		32 (1-1/4)			
Variable speed control switch			Yes			
Rotation reversing facility			Yes			
Job light			No	Single-light LED ("F" model only)		
Double insulation			Yes			
Power supply cord: m (ft)			Europe: 4.0 (13.1)		Australia: 2.0 (6.6)	Others: 2.5 (8.2)
Net weight: kg (lbs)			2.4 (5.4)	2.5 (5.6)	2.6 (5.9)	2.8 (6.3)

Standard equipment

Depth gauge 1 pc Side handle 1 pc Plastic carrying case1 pc

Note: The standard equipment for the tool shown above may differ from country to country.

Optional accessories

- * T.C.T hammer drill bits 5.5mm - 24mm (7/32" - 15/16") [HR2230: Maximum 22mm (7/8")]
- * Bull point 14mm (9/16")
- * Cold chisel 20mm (13/16")
- * Scaling chisels 38mm and 50mm (1-1/2" and 2")
- * Grooving chisels 8mm and 12mm (5/16" and 1/2")
- * Scraper assembly
- * Core bits

- * Center bits
- * Core bit adaptor
- * Rod 10
- * Core bits (dry type)
- * Taper shank adaptor
- * Taper shank T.C.T.hammer drill bits
- * Drill chuck ass'y
- * Drill chuck S13
- * Chuck key S13

- * Quick change drill chuck (keyless)
- * Quick change chuck for SDS-PLUS
- * Dust cups 5 and 9
- * Safety goggle
- * Bit grease
- * Blow out bulb
- * Dust extractor attachment
- * Hammer service kit

► **Features and benefits**

Capacity	Model	Operation Mode	LED	SDS PLUS only / QC*
22mm	HR2230	2 modes (Rotation only/ Rotation with hammering)	No	SDS-PLUS only
24mm	HR2460		No	
	HR2460F		Yes	
	HR2470	No		
	HR2470F	Yes		
	HR2470T	No	QC*	
HR2470FT	Yes			

* Changeable between Quick Change chuck for SDS-plus and Quick Change drill chuck (keyless)

Increased Durability

About 4 times as tough as the current by;

- 1) modification of impact bolt and its contact parts.
- 2) change in position of interia-air outlet hole and enhancement of sealing to prevent inside grease from leaking.
- 3) zigzag varnish to Armature.

40 Different Bit-angle Setting (exclusively for HR2470, HR2470F, HR2470T and HR2470FT)

Chisel adapter is not required.

Rotation Reversing System Using Brush Holder Unit

Features the following advantages:

- Service life of carbon brush is about 2.7 times as long as that of HR2450 series.
- Maintenance is easy because of the simple wiring structure compared with HR2450 series.
- Reverse rotation speed is as fast as forward rotation speed.

The above system enables the machine to meet electromagnetic compatibility-requirement without the stroke limiter of trigger in reverse rotation.

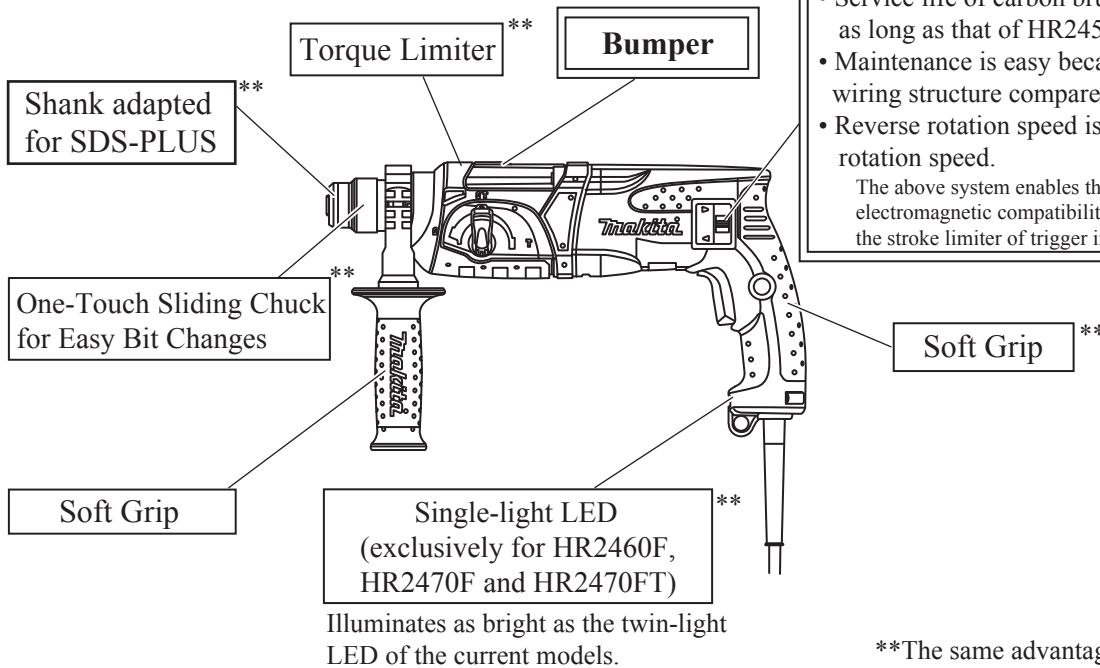

illuminates as bright as the twin-light LED of the current models.

**The same advantages as HR2450 series

Easy-to-change Chuck (Exclusively for HR2470T and HR2470FT)

Quick change chuck for SDS-PLUS

Change cover
Change cover line

Spindle

Quick change drill chuck (keyless)

Change cover
Change cover line

- 1) Grasp the change cover of the quick change chuck for SDS-plus and turn in the direction of the arrow until the change cover line moves from the symbol to the .
- 2) Pull the quick change chuck in the direction of the arrow.
- 3) Grasp the change cover of the quick change drill chuck and set the line to the symbol until a click can clearly be heard .

► Repair for 3 mode Rotary Hammers HR2470, HR2470F, HR2470T and HR2470FT

Note: Regarding the repair for 2 mode Rotary hammers, refer to the data as follows;
HR2230-NP.pdf, HR2460-NP.pdf, HR2460F-NP.pdf

CAUTION: Remove the Bit from the machine for safety before repair/ maintenance in accordance with the instruction manual!

[1] NECESSARY REPAIRING TOOLS

Code No.	Description	Use for
1R003	Retaining ring S pliers ST-2N	removing Ring spring 19
1R212	Tip for Retaining ring pliers	attachment of 1R003
1R004	Retaining ring S pliers ST-2	removing Ring spring 21 and Ring spring 29
1R022	Bearing plate (for arbor press)	attachment of 1R306 / Removing Ring 8 and Helical gear 26
1R023	Pipe ring (for arbor press)	removing Ring 8 and Helical gear 26
1R032	Bearing setting plate 8.2	assembling Swash bearing 10
1R033	Bearing setting plate 10.2	assembling Helical gear 26
1R038	Armature holder 32 set for use with vise	holding Tool holder when removing Ring spring 28 from Tool holder
1R164	Ring spring setting tool A	assembling Oil seal 25 and Needle bearing complete to Gear housing complete
1R165	Ring spring setting tool B	assembling Needle bearing complete into Gear housing complete
1R232	Pipe 30	assembling Oil seal 25 to Gear housing complete
1R252	Round bar for arbor 30-100	removing Oil seal 25 from Gear housing complete
1R269	Bearing extractor	removing Ball bearing 608ZZ from Swash bearing section
1R281	Round bar for arbor 7-50	removing Tool holder section, Ring 8 and Helical gear 26
1R291	Retaining ring S and R pliers	removing Retaining Ring S-7 from Cam shaft
1R306	Ring spring removing jig	removing Ring spring 29 from Tool holder
318132-2	Piston cylinder	assembling Ring spring 28 to Tool holder

[2] LUBRICATION

Apply the following grease to protect parts and product from unusual abrasion.

* Makita grease RB No.00 to the portions marked with black triangle

* Molybdenum disulfide lubricant to the portions marked with gray triangle

Item No.	Description	Portion to lubricate
35	O ring 16	Whole portion
36	Piston cylinder	(f) Inside where Striker moves
		(g) Hole for accepting Piston joint
		(h) Apply Molybdenum disulfide lubricant to the surface where (25) Tool holder contacts. (Refer to Fig. 2.)
44	Clutch cam	(i) Apply Molybdenum disulfide lubricant to the groove.
		(j) Side where (46) Swash bearing 10 engages
45	Cam shaft	Surface where (44) Clutch cam and (90) Spur gear 10 contact
46	Swash bearing 10	Pole portion which is inserted into Piston joint
47	Helical gear 26	Teeth portion
56	Inner housing complete	Space where Armature's drive end and (47) Helical gear 26 engages
90	Spur gear 10	Teeth portion where (23) Spur gear 51 engages (Refer to Fig. 2)

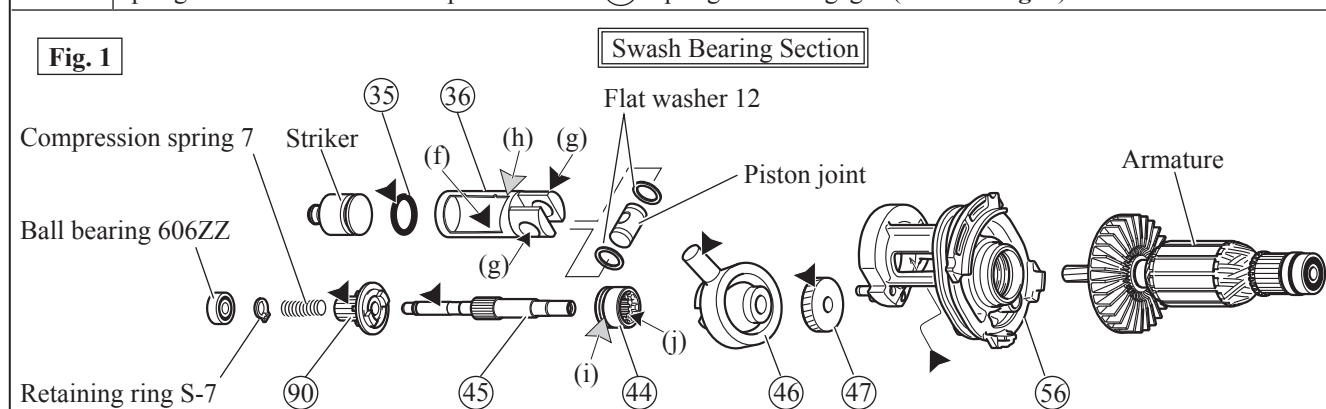

► **Repair for 3 mode Rotary Hammers HR2470, HR2470F, HR2470T and HR2470FT**

[2] LUBRICATION

Apply Makita grease RB. No.00 to the following portions designated with the black triangle to protect parts and product from unusual abrasion.

Item No.	Description	Portion to lubricate
1	Cap 35	Lip portion where Bit is inserted
13	Change lever	Pin portion
16	O ring 17	Whole portion
17	Gear housing complete	Inside where Swash bearing section rotates
23	Spur gear 51	(a) Teeth portion, (b) Surface where Clutch portion of (25) Tool holder contacts
24	Steel ball 7	Whole portion
25	Tool holder complete	(c) Surface where Needle bearing complete contacts
		(d) Surface where Plane bearing 28 of (56) Inner housing contacts
		(e) Inside where (36) Piston cylinder reciprocates
25a	Tool holder guide complete	(f) Surface to which Tool holder is joined
		(g) Inside where (36) Piston cylinder reciprocates
		(h) Surface where Plane bearing 28 of (56) Inner housing contacts
29	Ring 10	Surface where Cushion ring 13 contacts
32	O ring 9	Whole portion
99	Steel ball 7	Whole portion
104	Steel ball 6	Whole portion

Fig. 2

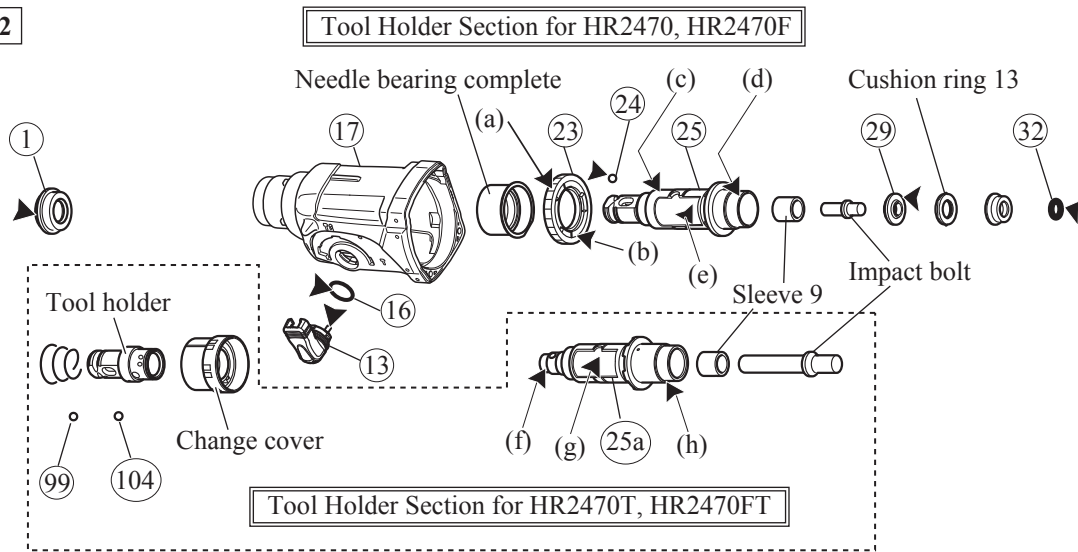

► **Repair for 3 mode Rotary Hammers HR2470, HR2470F, HR2470T and HR2470FT**

[3] DISASSEMBLY/ASSEMBLY

[3] -1. Tool Holder Section

DISASSEMBLING for HR2470, HR2470F

Fig. 3

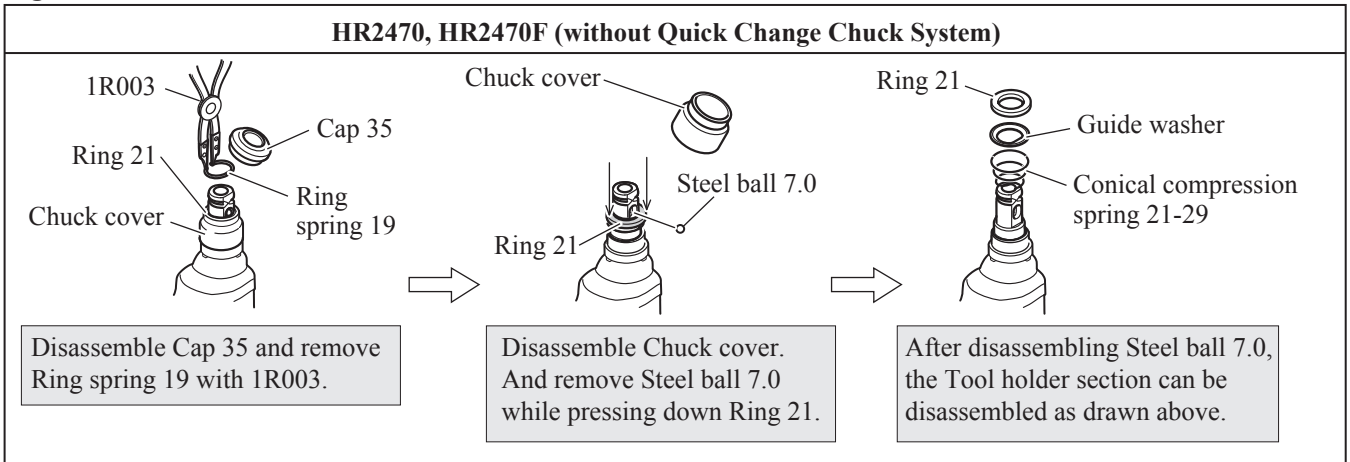

ASSEMBLING for HR2470, HR2470F

(1) Do the reverse of Disassembling steps. Refer to **Fig. 3**.

Note: Be sure to place the flat portion of Ring spring 19 on Steel ball 7.0.

DISASSEMBLING for HR2470T, HR2470FT

Fig. 4

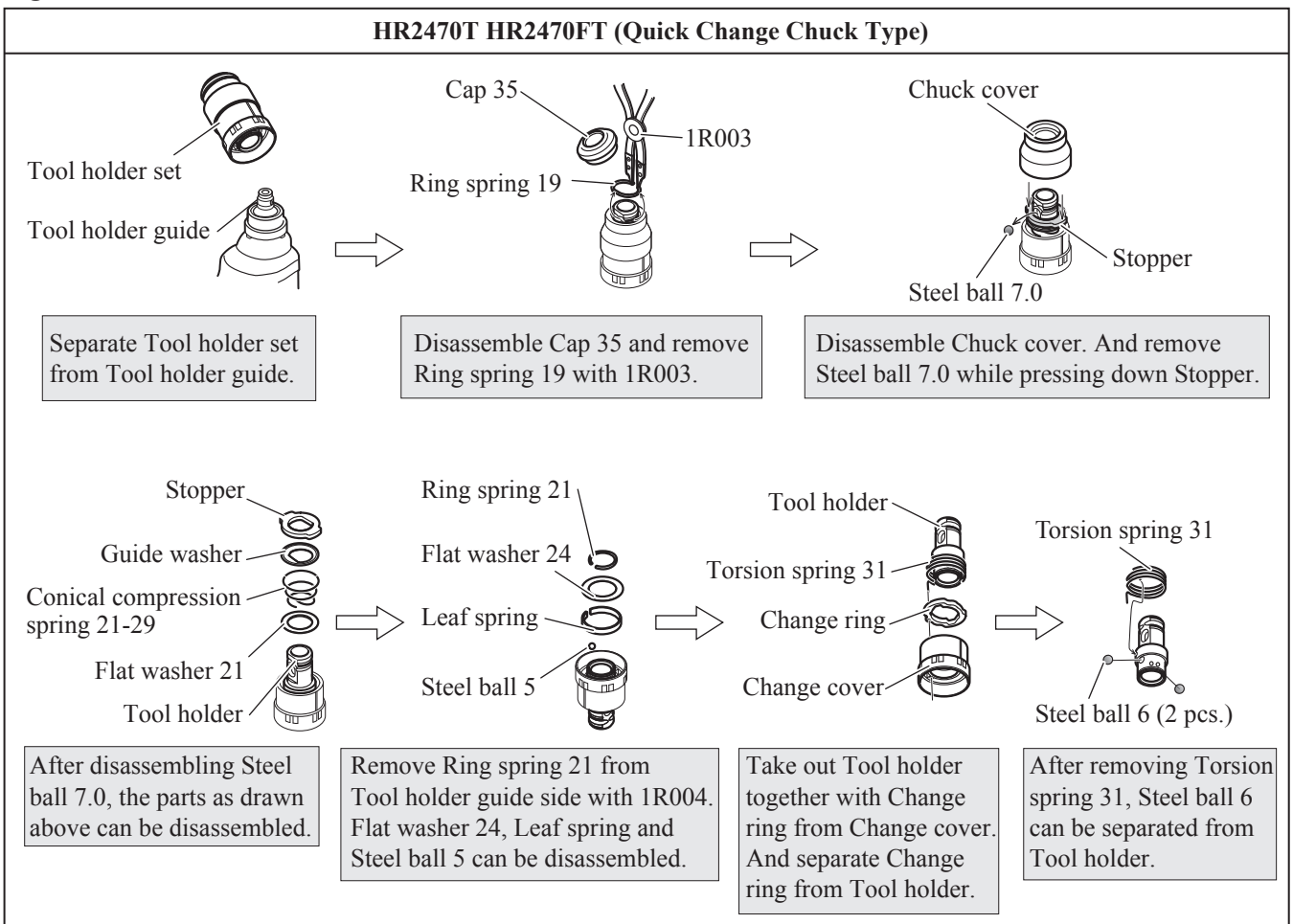

► **Repair for 3 mode Rotary Hammers HR2470, HR2470F, HR2470T and HR2470FT**

[3] DISASSEMBLY/ASSEMBLY

[3] -1. Tool Holder Section

ASSEMBLING for HR2470T, HR2470FT

- (1) Assemble Change ring to Change cover. (Fig. 5)
- (2) Assemble Torsion spring 31 to Tool holder. (Fig. 6)
- (3) Assemble Tool holder to Change cover. (Fig. 7)

Fig. 5

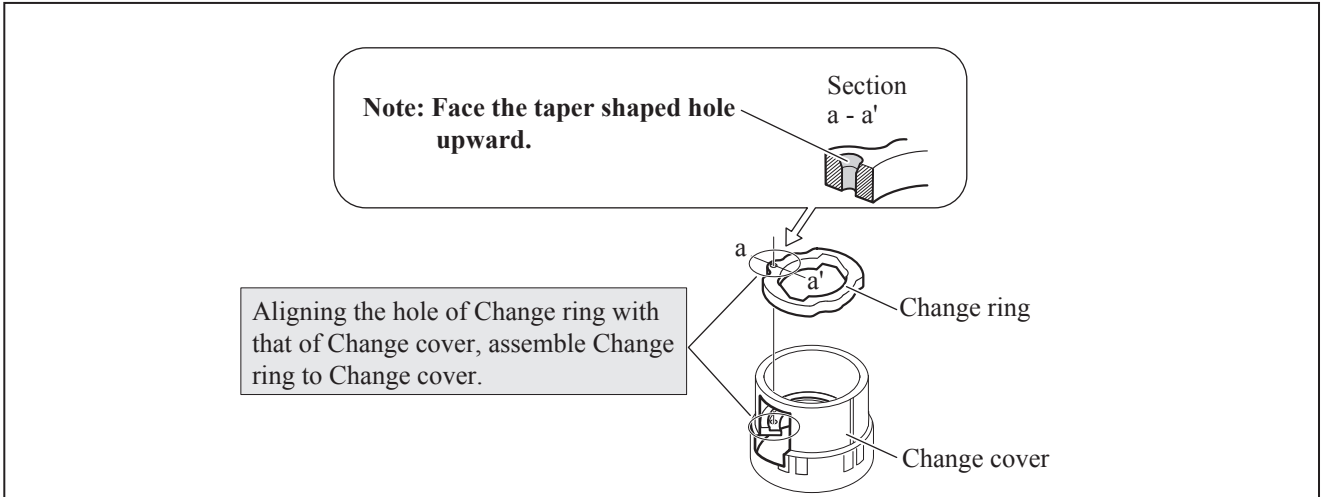

Fig. 6

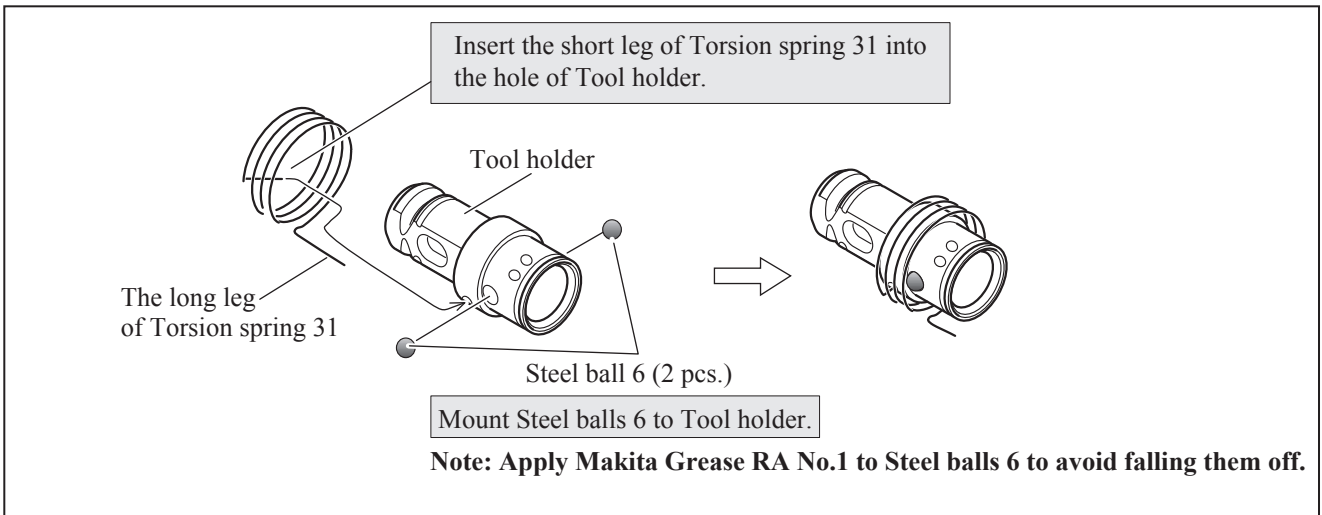
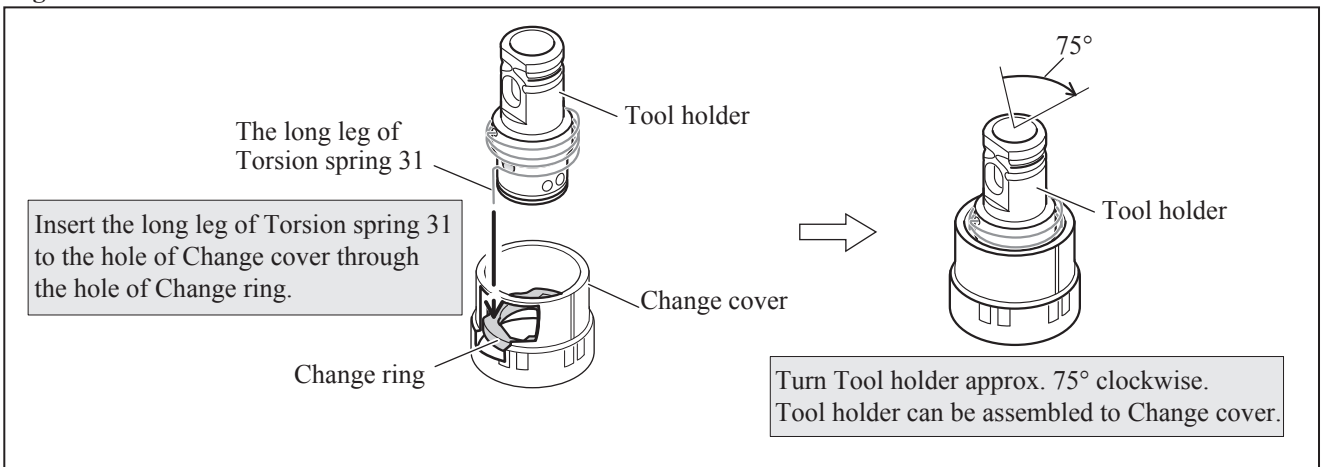

Fig. 7



► **Repair for 3 mode Rotary Hammers HR2470, HR2470F, HR2470T and HR2470FT**

[3] DISASSEMBLY/ASSEMBLY

[3] -1. Tool Holder Section (cont.)

ASSEMBLING for HR2470T, HR2470FT

- (4) Attach Steel ball 5.0 between the ends of Leaf spring, and mount them to the groove between Change lever and Tool holder. (Fig. 8)
- (5) Mount Flat washer 24 on Leaf spring, and secure them with Ring spring 21. (Fig. 8)
- (6) As for the assembling of Cap 35 side, do the reverse of disassembling steps. Refer to Fig. 4.

Fig. 8

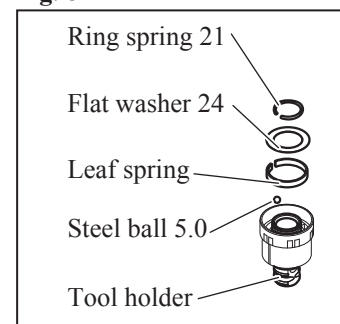

[3] -2. Drill Chuck Assembly (for HR2470T, HR2470 FT)

DISASSEMBLING

Drill chuck assembly can be disassembled as drawn in Figs. 9 to 13.

Fig. 9

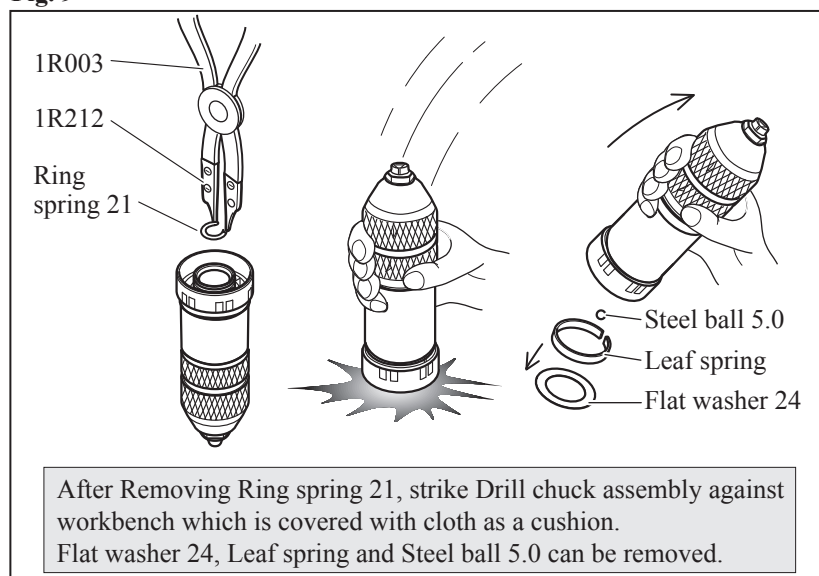

Fig. 10

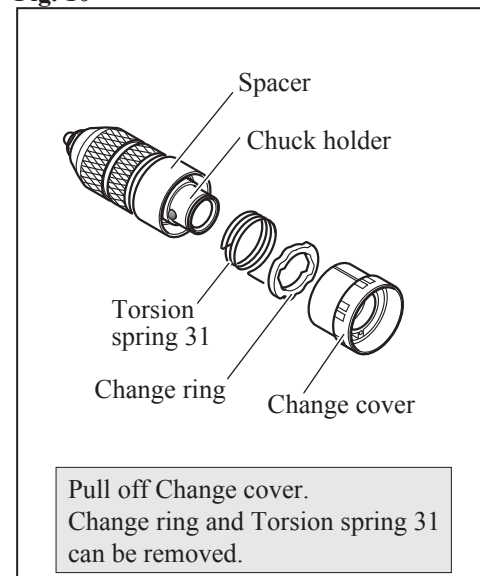

Fig. 11

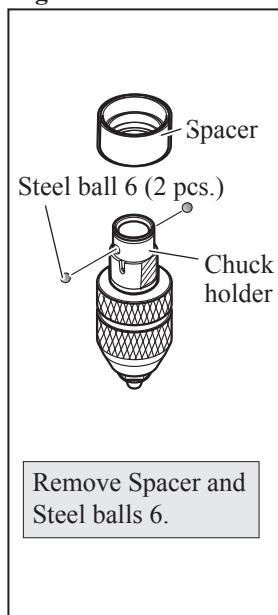

Fig. 12

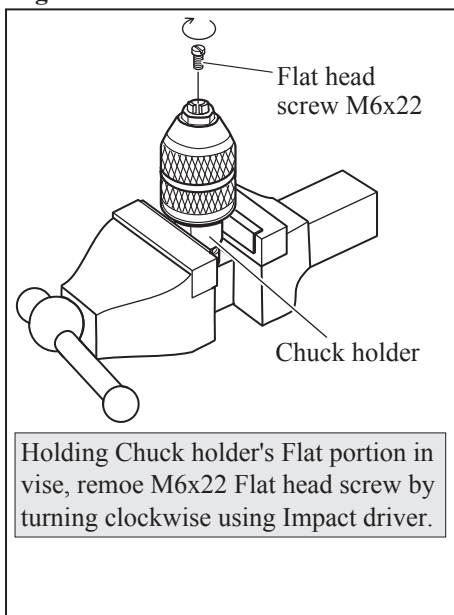
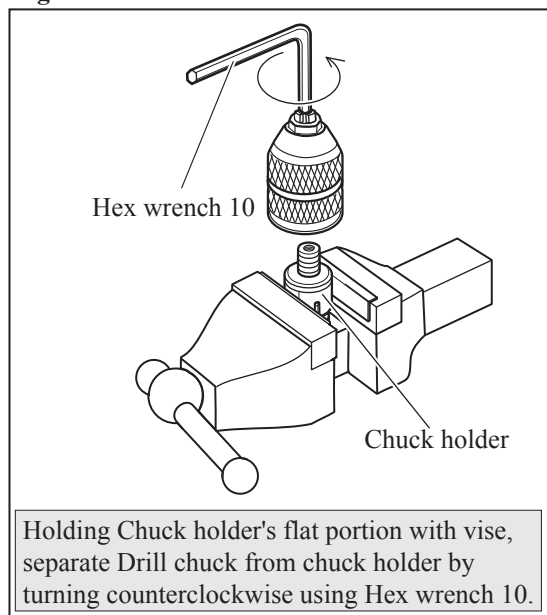

Fig. 13



► **Repair for 3 mode Rotary Hammers HR2470, HR2470F, HR2470T and HR2470FT**

[3] DISASSEMBLY/ASSEMBLY

[3] -2. Drill Chuck Assembly (for HR2470T, HR2470FT) (cont.)

ASSEMBLING

- (1) Holding Chuck holder's Flat portion in vise. Assemble Drill chuck to Chuck holder by turning clockwise using Hex wrench 10. (Fig. 13)
- (2) Secure Drill chuck with M6x22 Flat head screw by turning counterclockwise using Impact driver. Refer to Fig. 12.
- (3) Assemble Drill chuck to Spacer. (Fig. 14) And mount Steel ball 6. (Fig. 15)
- (4) Mount Torsion spring 31. And assemble the Drill chuck to Change cover. (Fig. 16)
- (5) Mount Steel ball 5, Leaf spring and Flat washer 24 to Chuck holder. And secure them with Ring spring 21. (Fig. 17).

Fig. 14

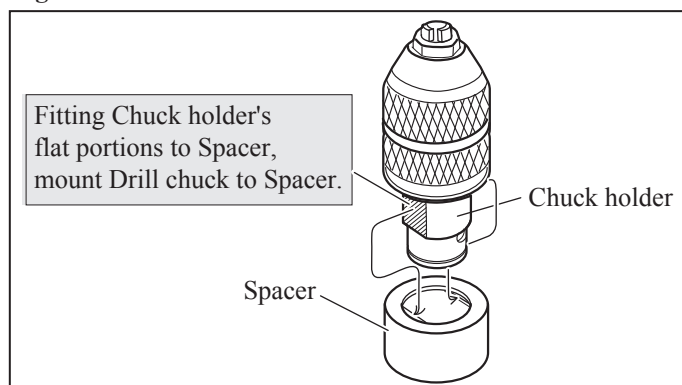

Fig. 15

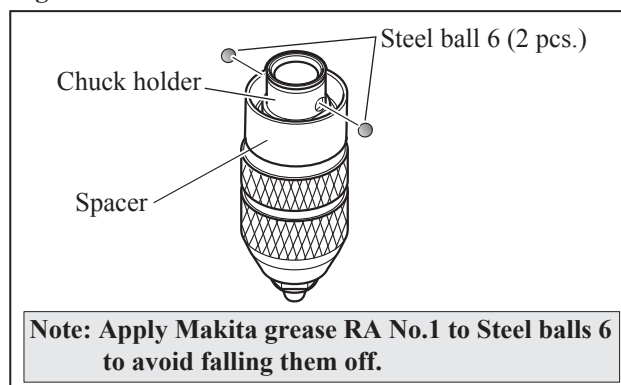

Fig. 16

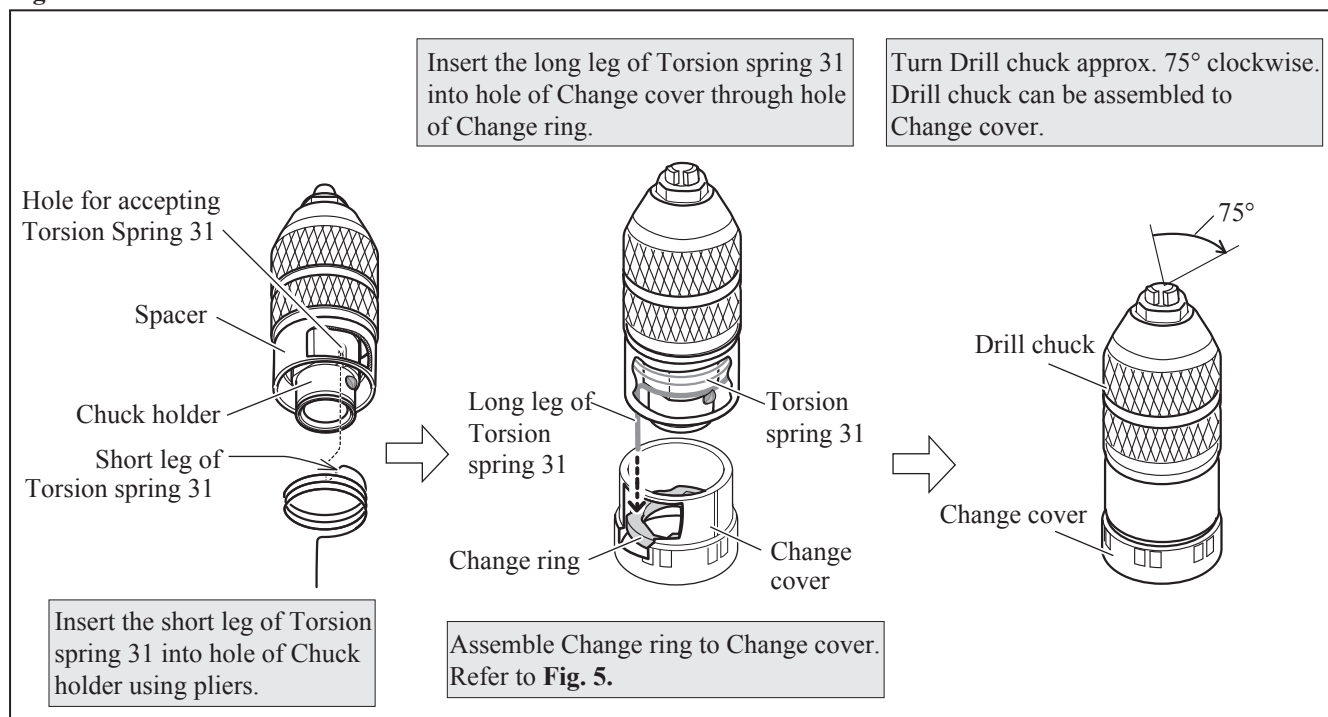
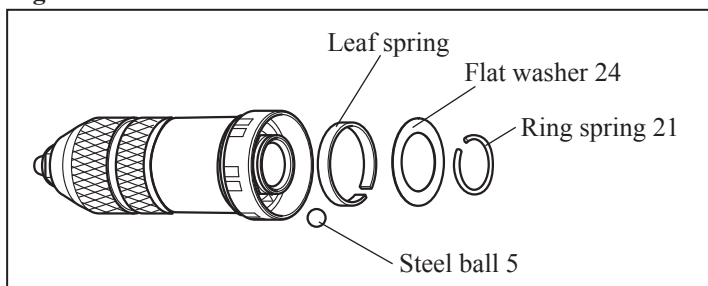

Fig. 17



► **Repair for 3 mode Rotary Hammers HR2470, HR2470F, HR2470T and HR2470FT**

[3] DISASSEMBLY/ASSEMBLY

[3] -3. Change Lever

DISASSEMBLING

- (1) Remove dust and dirt from Change lever and the grooved area on the Motor housing circled in **Fig. 18**.
- (2) Set Change lever to drill mode while pushing Lock button. (**Fig. 19**)
- (3) Push Lock button further into the inner bottom of Change lever (**Fig. 20**) and turn Change lever to the left fully.
- (4) Lift up the hinge position of Change lever (**Fig. 21**) Now, change lever is removed.

When Change lever is difficult to remove, lever up the hinge portion with a slotted screwdriver.

Fig. 18

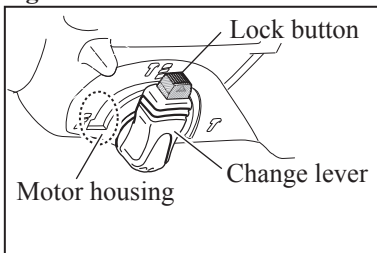

Fig. 19

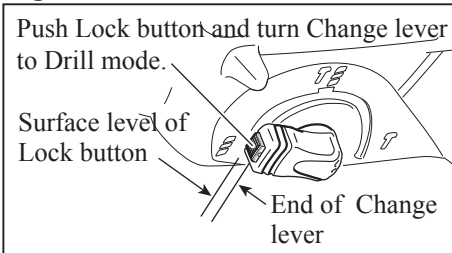

Fig. 21

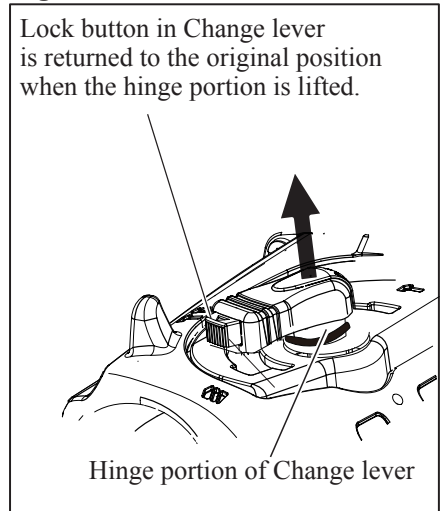
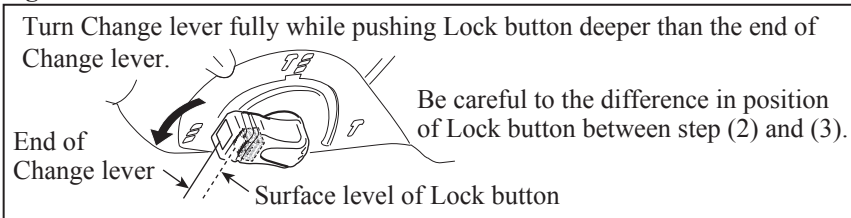

Fig. 20



ASSEMBLING

- (1) Assemble Motor housing to Gear housing.
- (2) Align the direction of Change lever with hammer mode position and insert Change lever into Gear housing. (**Fig. 22**).
Note: Change lever is not completely fit into Motor housing at this time.
- (3) While pushing Lock button deeply into the inner bottom of Change lever, turn Change lever to the left further than drill mode position as drawn in **Fig. 23**.
- (4) Keep pushing Lock lever deeply and tap Change lever with a plastic hammer to fit the hinge portion into Motor housing completely. (**Fig. 24**)
- (5) Make sure to check if Change lever is smoothly set to drill mode, hammer drill mode and hammer mode after assembling.

Fig. 22

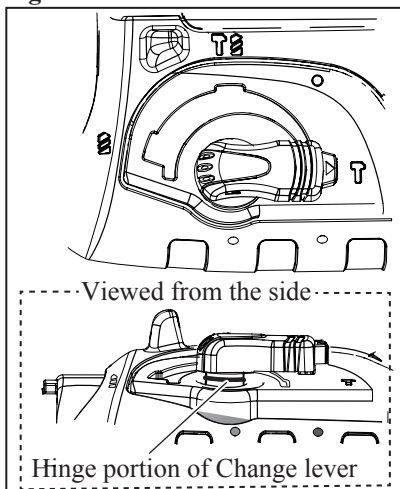

Fig. 23

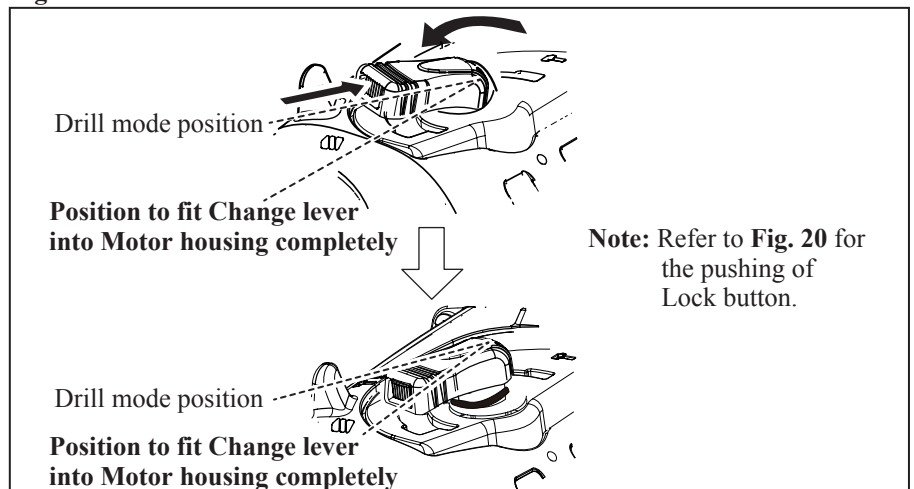
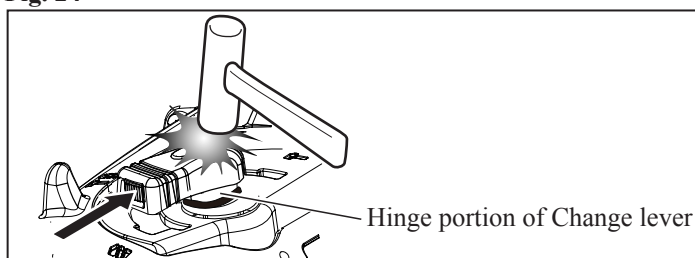

Fig. 24



► **Repair for 3 mode Rotary Hammers HR2470, HR2470F, HR2470T and HR2470FT**

[3] DISASSEMBLY/ASSEMBLY

[3] -4. Armature

DISASSEMBLING

(1) Remove Handle cover, and disconnect Carbon brush from Armature's commutator. (Figs. 25 and 26)

Fig. 25

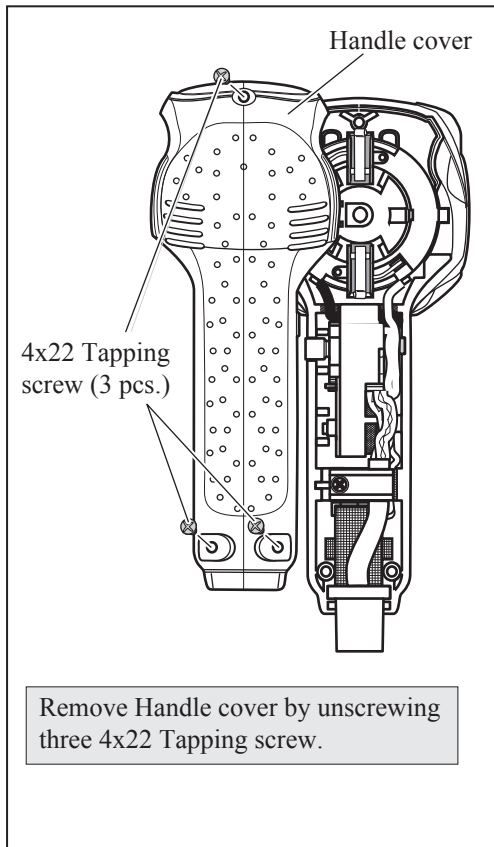
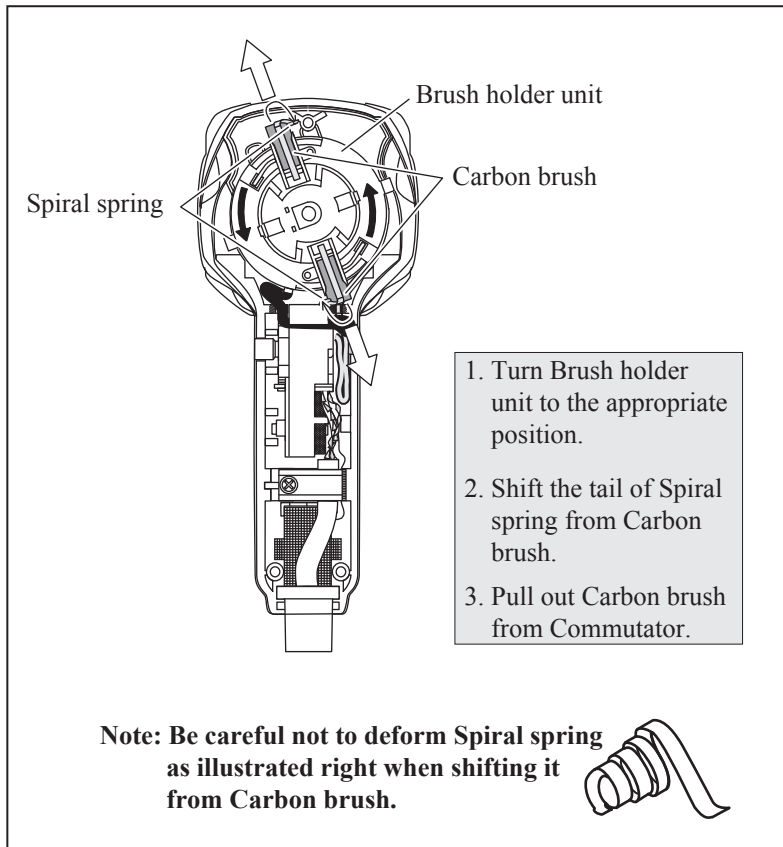

Fig. 26



(2) Separate Gear housing complete from Motor housing. And disassemble Armature from Gear housing complete. (Figs. 27 and 28)

Fig. 27

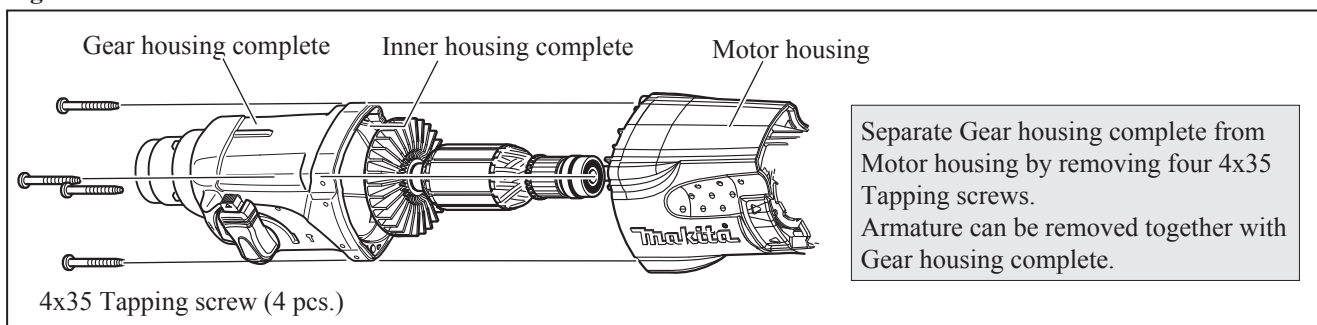
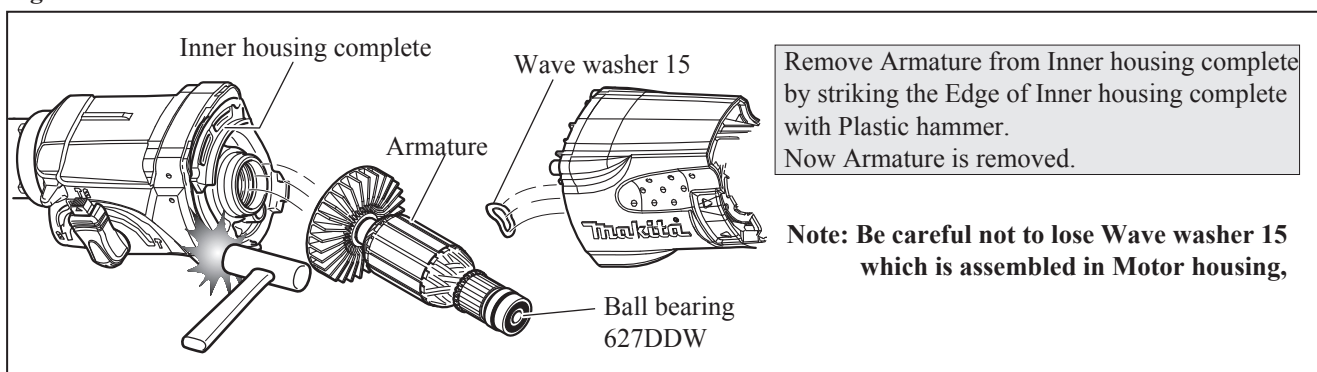

Fig. 28



► **Repair for 3 mode Rotary Hammers HR2470, HR2470F, HR2470T and HR2470FT**

[3] DISASSEMBLY/ ASSEMBLY

[3] -4. Armature (cont.)

ASSEMBLING

Do the reverse of disassembling steps.

Note: Do not forget to assemble Wave washer 15 to Bearing box portion of Motor housing. Refer to Fig. 28.

[3] -5. Torque Limiter Section

DISASSEMBLING

- (1) As for **HR2470** and **HR2470F**, disassemble Tool holder section as illustrated in **Fig. 3**.
As for **HR2470T** and **HR2470FT**, remove Tool holder set as per the left top illustration in **Fig. 4**.
- (2) Disassemble Change lever as illustrated in **Figs.18 and 19**.
- (3) Separate Gear housing complete from Motor housing. And then, remove Armature from Gear housing complete. (**Figs. 22 to 25**)
- (4) Disassemble Torque limiter section as illustrated in **Figs. 29 and 30**.
- (5) Washer 31, Compression spring 32 and Spur gear 51 are secured to Tool holder (guide) complete with Ring spring 29. Remove the Ring spring 29 as illustrated in **Figs. 31 and 32**.

Fig. 29

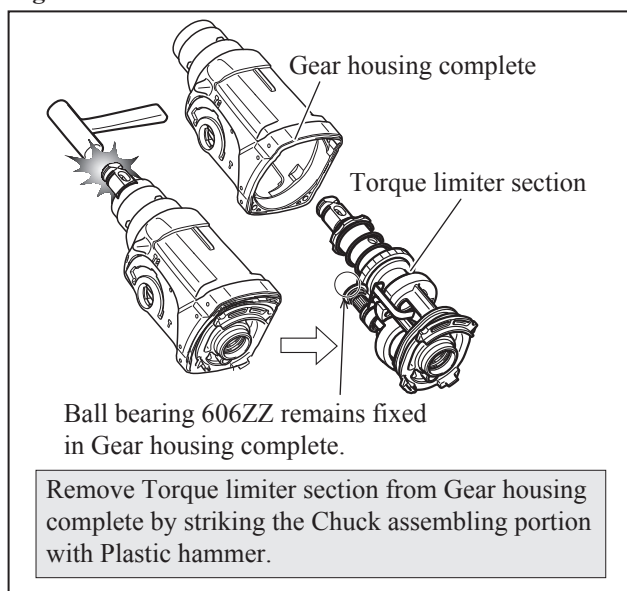

Fig. 30

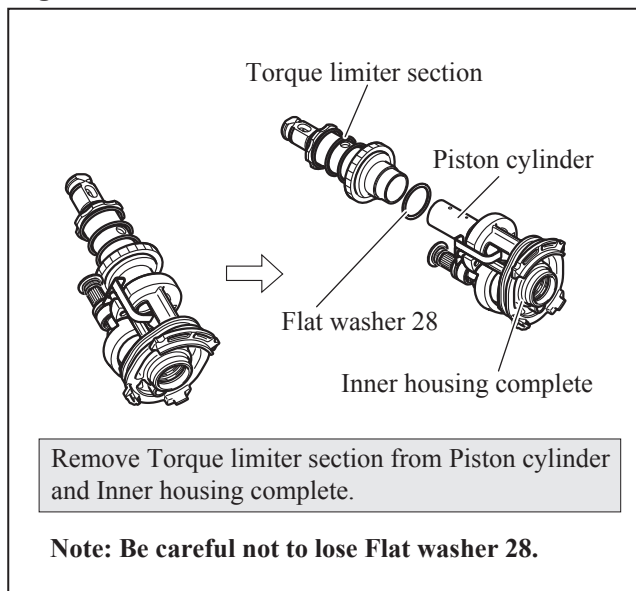

Fig. 31

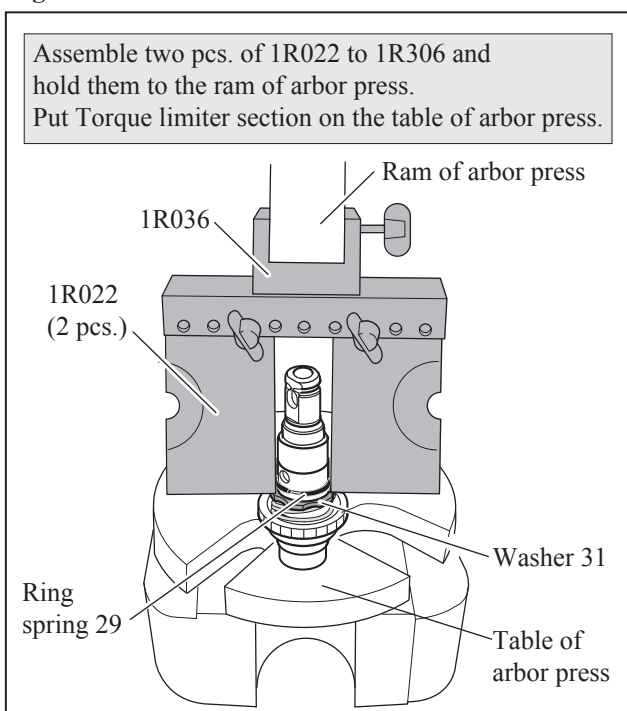
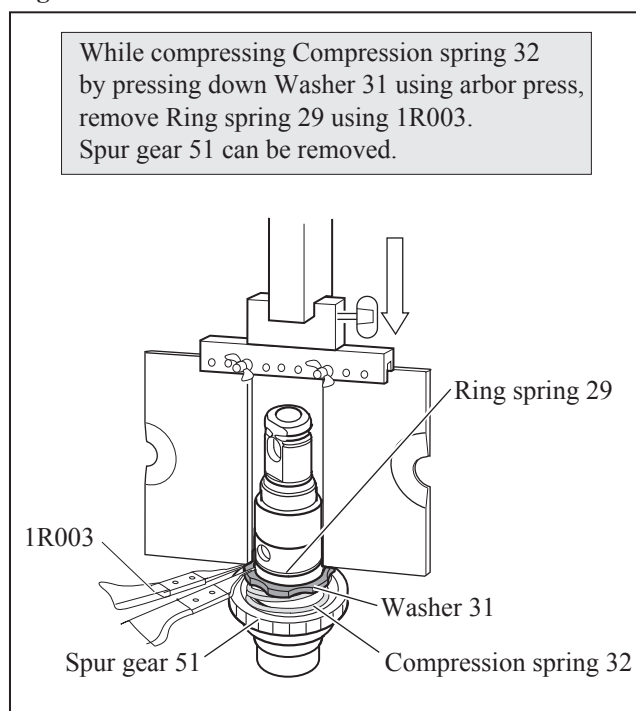

Fig. 32



► Repair for 3 mode Rotary Hammers HR2470, HR2470F, HR2470T and HR2470FT

[3] DISASSEMBLY/ ASSEMBLY

[3] -5. Torque Limiter Section (cont.)

DISASSEMBLING

(6) Now the Torque limiter section can be disassembled as illustrated in **Fig. 33**.

Fig. 33

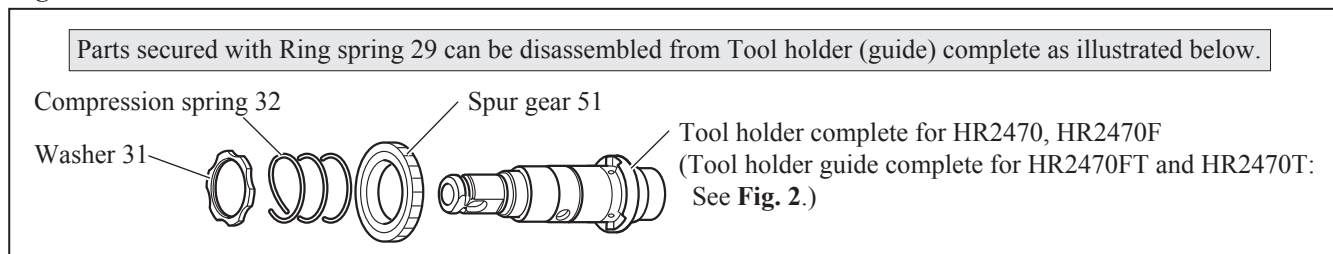

ASSEMBLING

Do the reverse of disassembling steps.

Note: Do not forget to assemble Flat washer 28 between Torque limiter section and Inner housing complete.

Refer to Fig. 33.

[3] DISASSEMBLY/ ASSEMBLY

[3] -6. Needle Bearing Complete and Oil Seal 25

DISASSEMBLING

(1) Disassemble Torque limiter section and Inner housing complete from Gear housing complete.

See Disassembly of [3] -5. **Torque Limiter Section.**

(2) Insert Inner housing complete into Gear housing complete. (**Fig. 34**)

(3) Remove Needle bearing complete and Oil seal 25. (**Fig. 35**)

Fig. 34

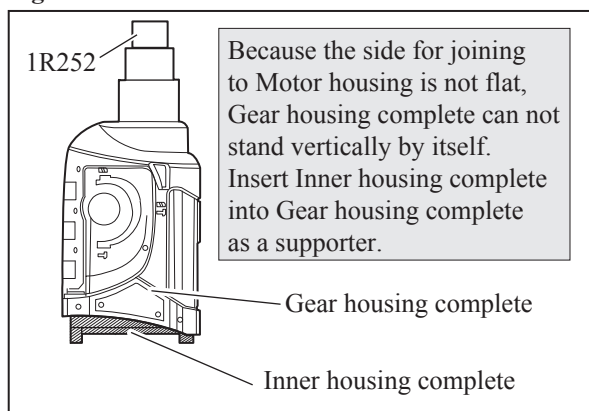
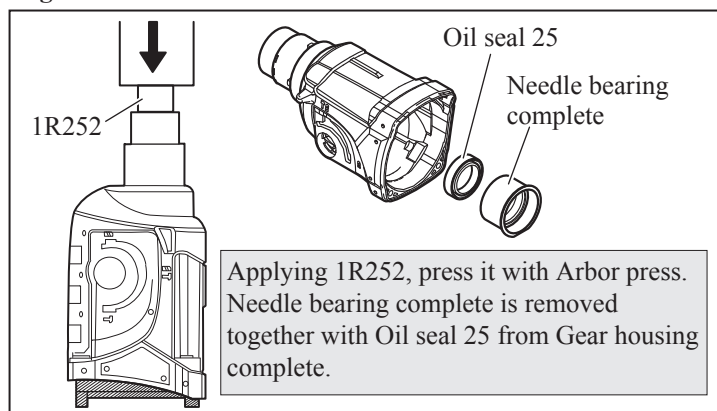

Fig. 35



► **Repair for 3 mode Rotary Hammers HR2470, HR2470F, HR2470T and HR2470FT**

[3] DISASSEMBLY/ ASSEMBLY

[3] -6. Needle Bearing Complete and Oil Seal 25

ASSEMBLING

- (1) Assemble Oil seal 25 to Gear housing complete in the order of **Figs. 36 and 37**.
- (2) Assemble Needle bearing complete as illustrated in **Figs. 38 and 39**.

Fig. 36

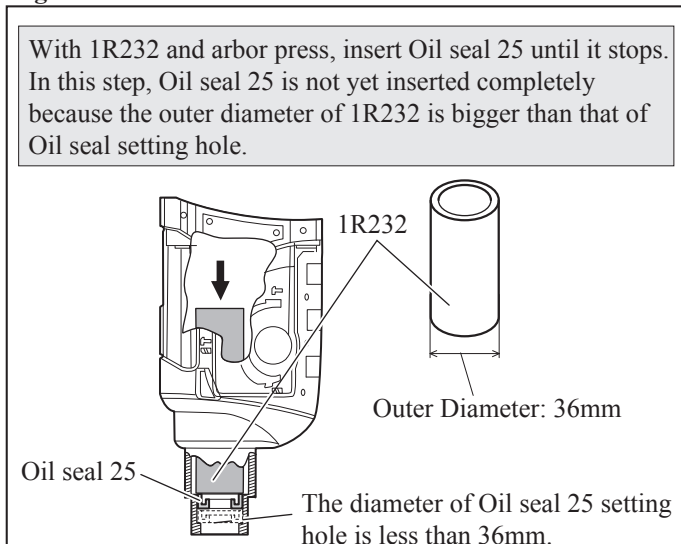

Fig. 37

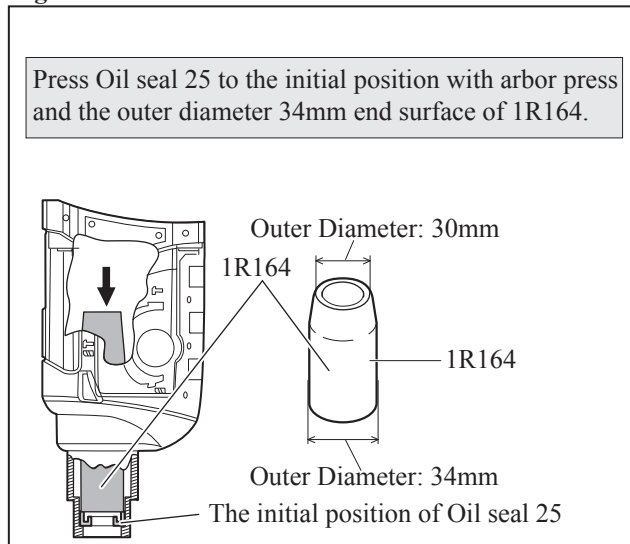

Fig. 38

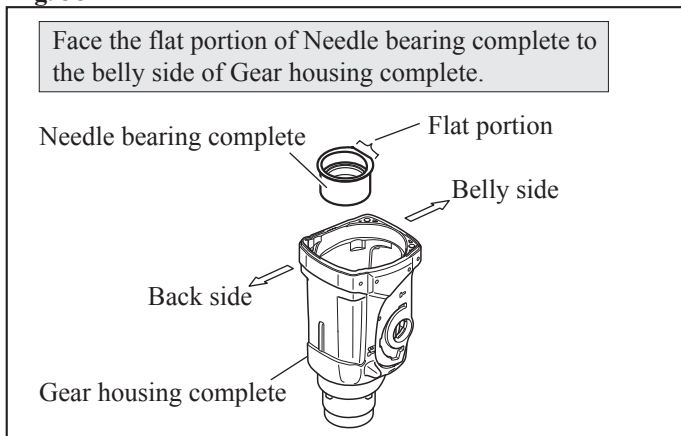
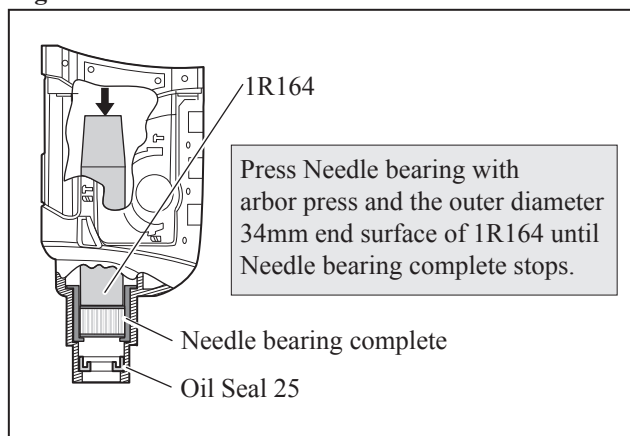

Fig. 39



[3] DISASSEMBLY/ ASSEMBLY

[3] -6A. The other way to remove/ assemble Needle Bearing Complete

DISASSEMBLING

Fig. A

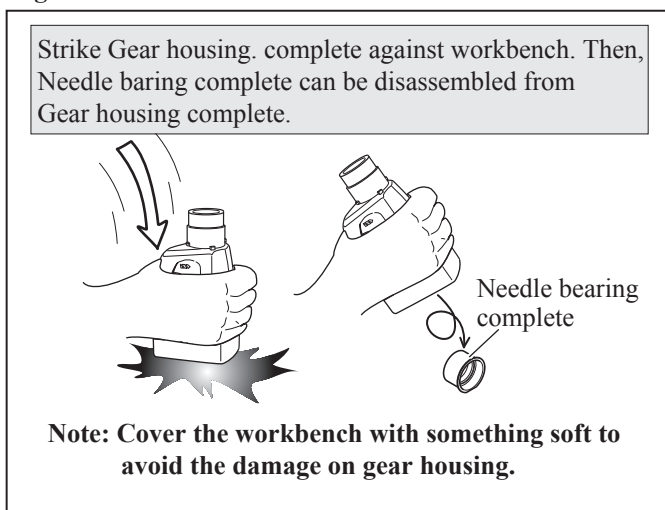

ASSEMBLING

Fig. B

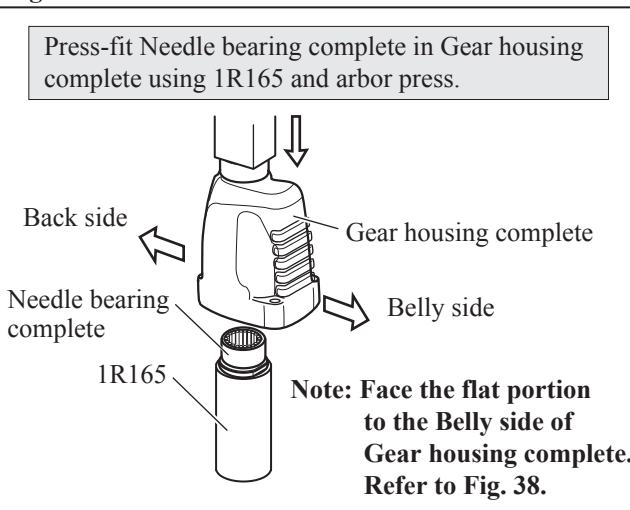

► **Repair for 3 mode Rotary Hammers HR2470, HR2470F, HR2470T and HR2470FT**

[3] DISASSEMBLY/ ASSEMBLY

[3] -7. Impact Bolt Section

DISASSEMBLING

- (1) Referring to "[3] -5. Torque Limiter Section", disassemble Ring spring 29, Washer 31, Compression spring 32 and Spur gear 51 from Tool holder (guide) complete. Refer to **Figs. 29 to 33**.
- (2) Holding Gear housing complete in vise and 1R038, Tap the other Ring spring 28 in Tool holder complete as illustrated in **Figs. 40 and 41**.
- (3) Remove Ring spring 28 from Tool holder complete and disassemble Impact bolt section. (**Figs. 42 to 43**)

Fig. 40

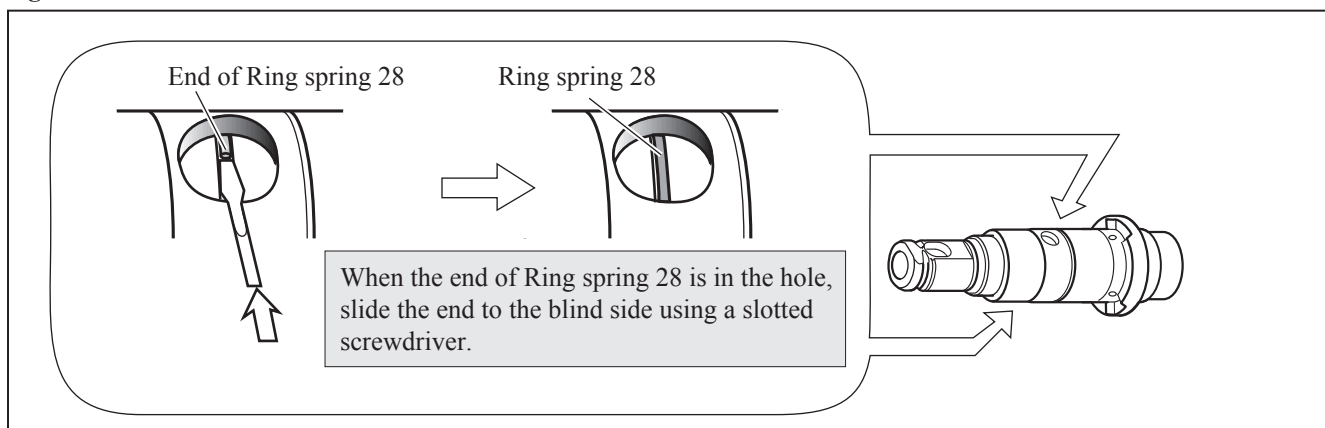

Fig. 41

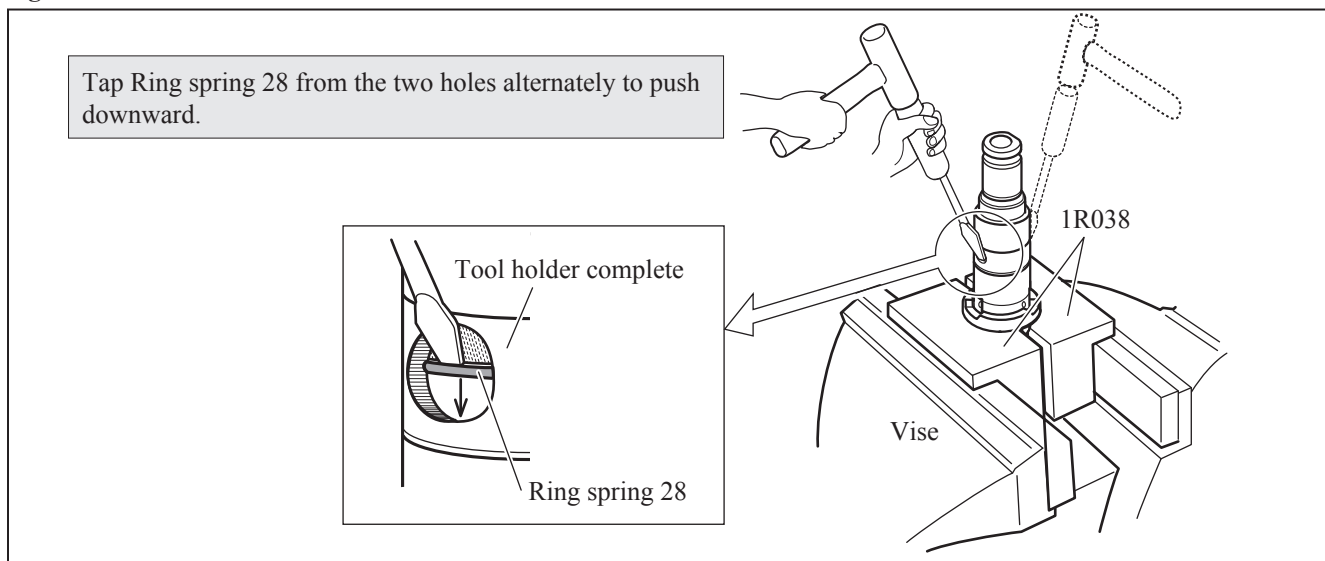

Fig. 42

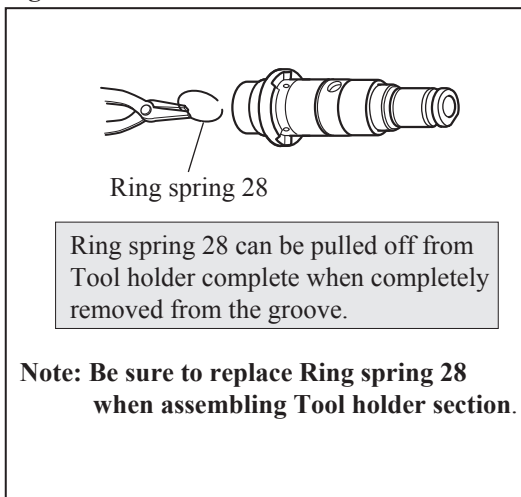
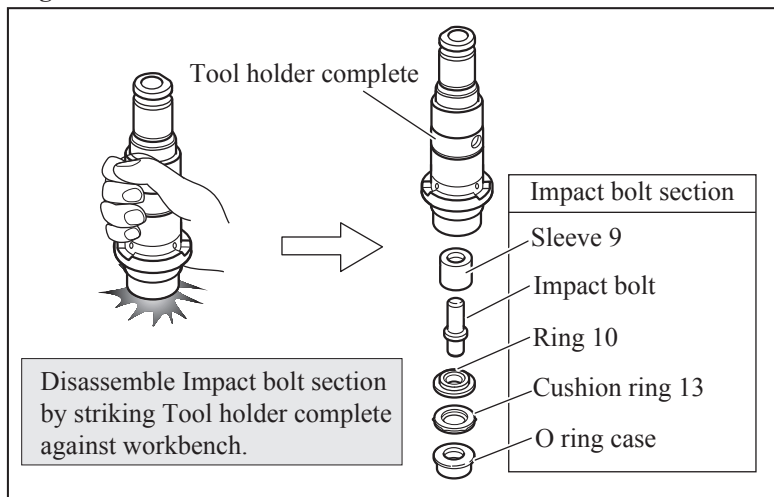

Fig. 43



► **Repair for 3 mode Rotary Hammers HR2470, HR2470F, HR2470T and HR2470FT**

[3] DISASSEMBLY/ ASSEMBLY

[3] -7. Impact Bolt Section

ASSEMBLING

(1) Referring to **Figs. 44, 45/A and 46**, assemble the Impact bolt section to Tool holder complete as illustrated in **Fig. 47**.

Fig. 44

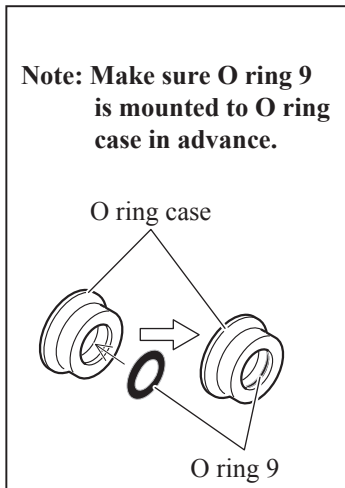

Fig. 45

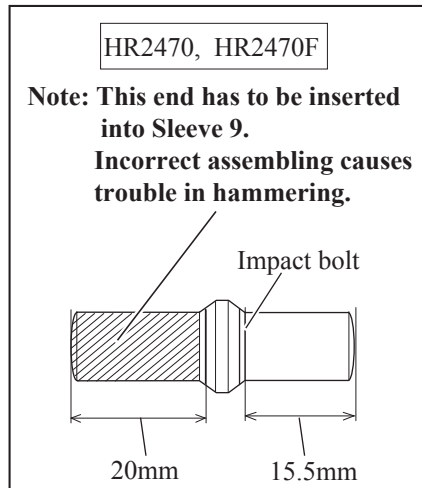

Fig. 45A

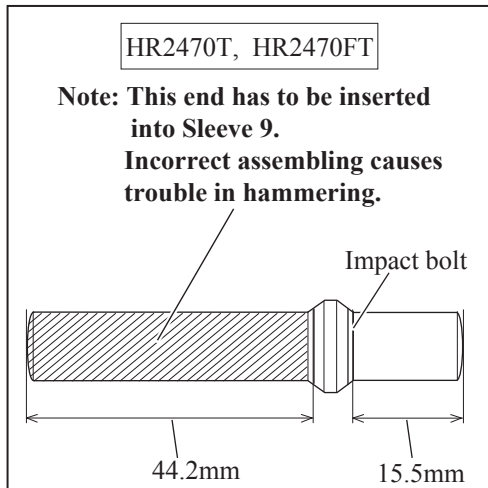

Fig. 46

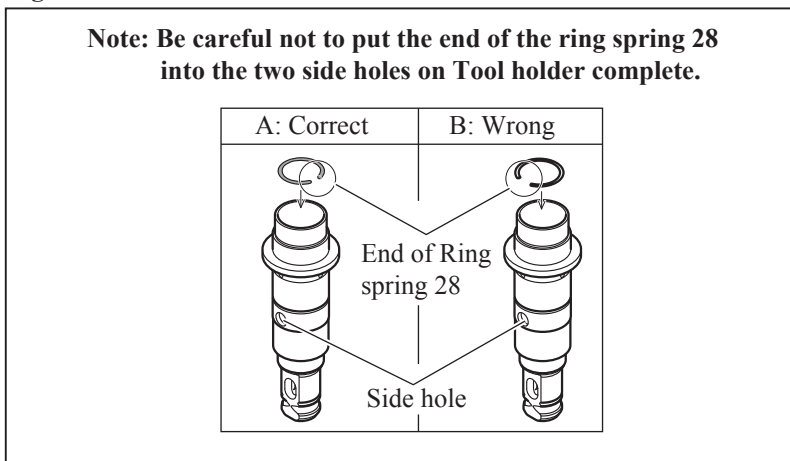
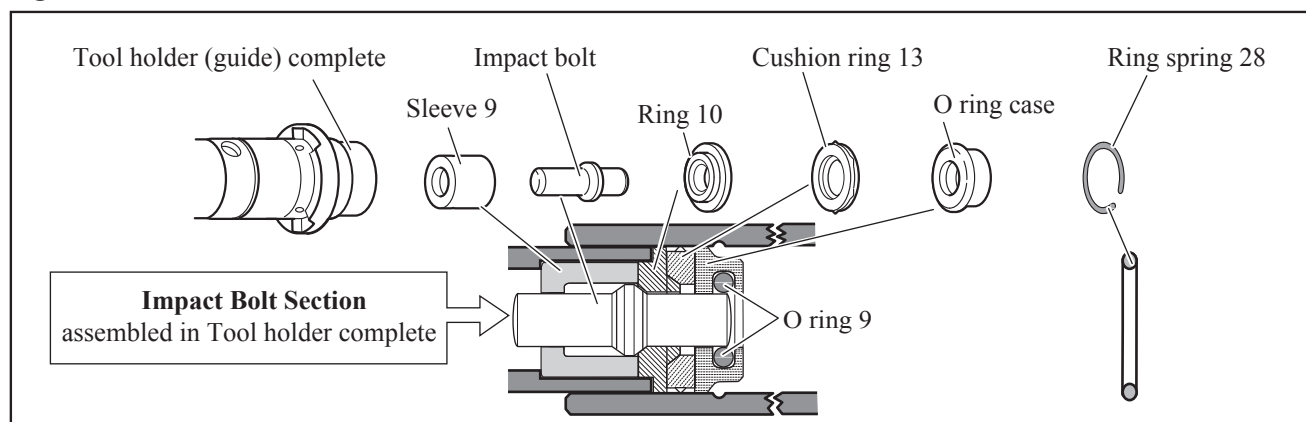

Fig. 47



► Repair for 3 mode Rotary Hammers HR2470, HR2470F, HR2470T and HR2470FT

[3] DISASSEMBLY/ ASSEMBLY

[3] -7. Impact Bolt Section (cont.)

ASSEMBLING

(2) Push Ring spring 28 with Piston cylinder until it fits to the inner groove of Tool holder complete. (Fig. 48)

Fig. 48

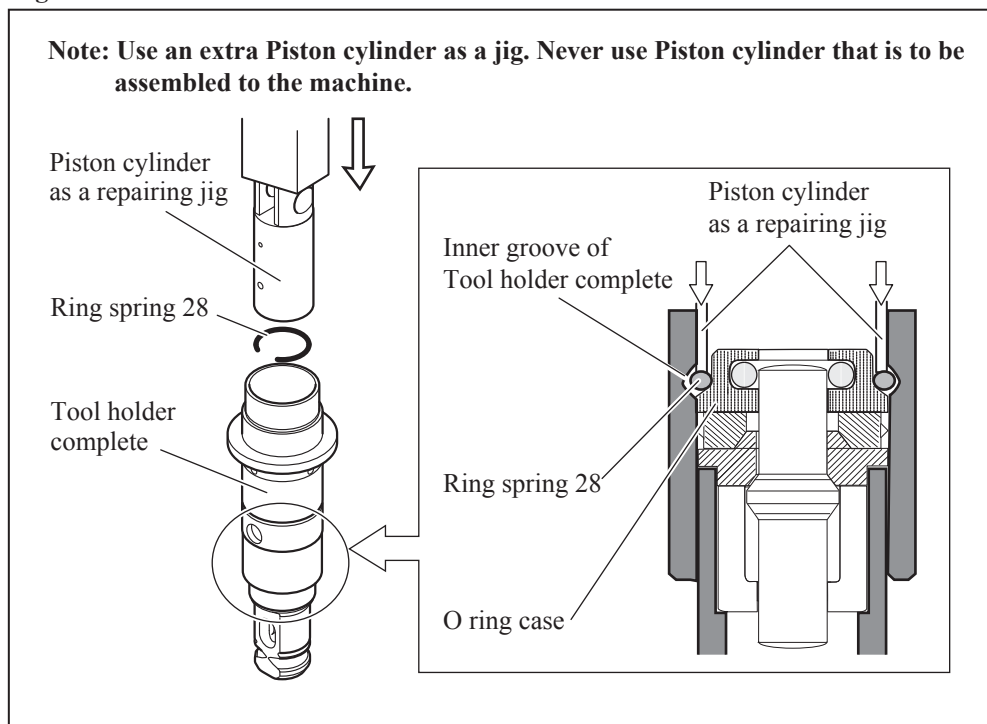

[3] -8. Swash Bearing Section

DISASSEMBLING

(1) As for **HR2470** and **HR2470F**, disassemble Tool holder section as illustrated in **Fig. 3**.

As for **HR2470T** and **HR2470FT**, remove Tool holder set as per the left top illustration in **Fig. 4**.

(2) Disassemble Change lever as illustrated in **Figs.18 and 21**.

(3) Separate Gear housing complete from Motor housing. And then, remove Armature from Gear housing complete. (Refer to **Figs. 25 to 28**.)

(4) Remove Stop ring E-4, Flat washer 5 and Compression spring 6 from pin of Inner housing complete. (Fig. 49)

(5) Remove two M4x12 Hex socket head bolts that fasten Bearing retainer to Inner housing complete. (Fig. 50)

Fig. 49

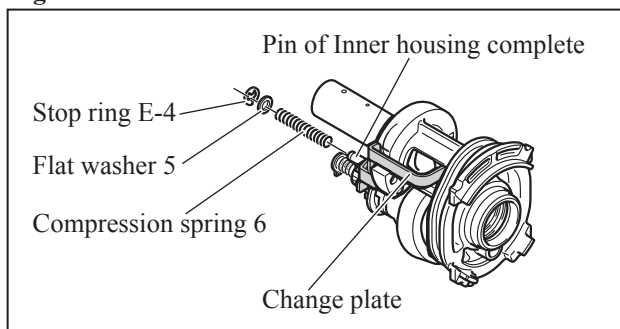
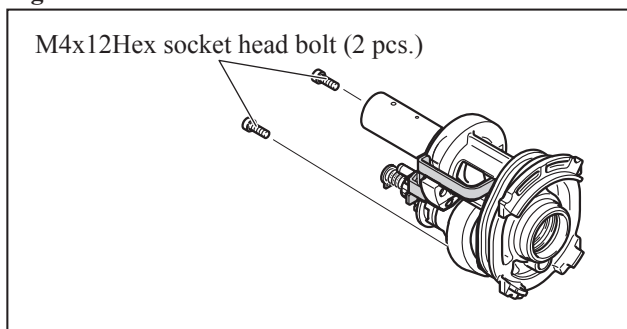

Fig. 50



► **Repair for 3 mode Rotary Hammers HR2470, HR2470F, HR2470T and HR2470FT**

[3] DISASSEMBLY/ ASSEMBLY

[3] -8. Swash Bearing Section (cont.)

DISASSEMBLING

(6) Move Piston cylinder to the rear dead center position (**Fig. 51**).

(7) Remove Swash bearing section from Inner housing by pulling in the direction of the arrow. Then, remove Change plate from the groove of Clutch cam. (**Fig. 52**).

Fig. 51

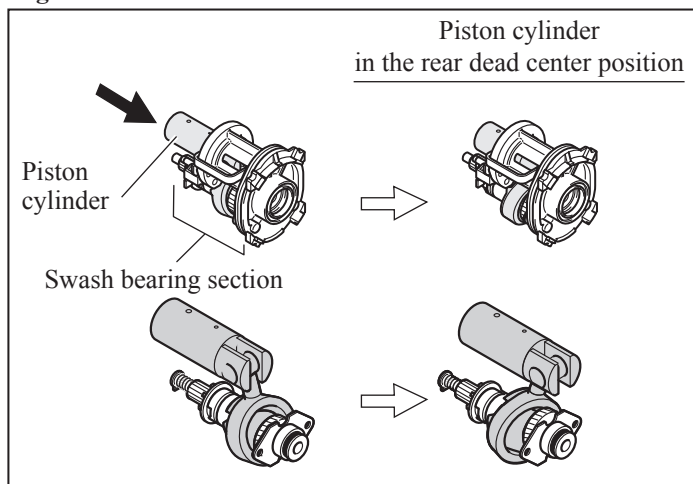
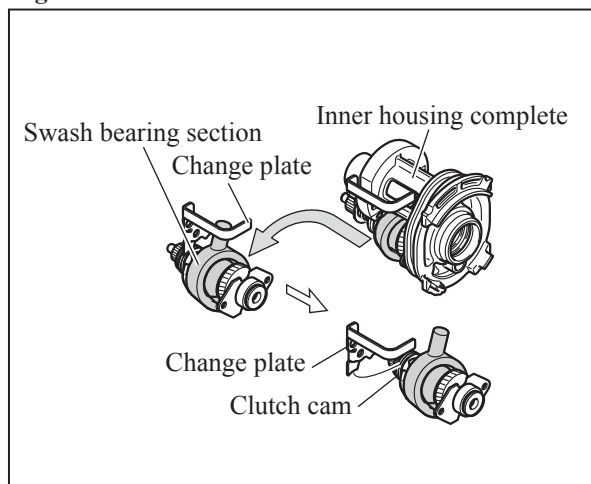

Fig. 52



(8) Remove Ball bearing 606ZZ from Gear housing complete using the removed Swash bearing section as a jig as follows;

- * Insert Cam shaft of Swash bearing section into the Ball bearing again.
- * Tilt the Ball bearing a little bit by moving Swash bearing section as illustrated to **left in Fig. 53**.
- * Ball bearing 606ZZ can now be removed by lightly tapping the edge of Gear housing complete with plastic hammer as illustrated to **right in Fig. 53**.

Fig. 53

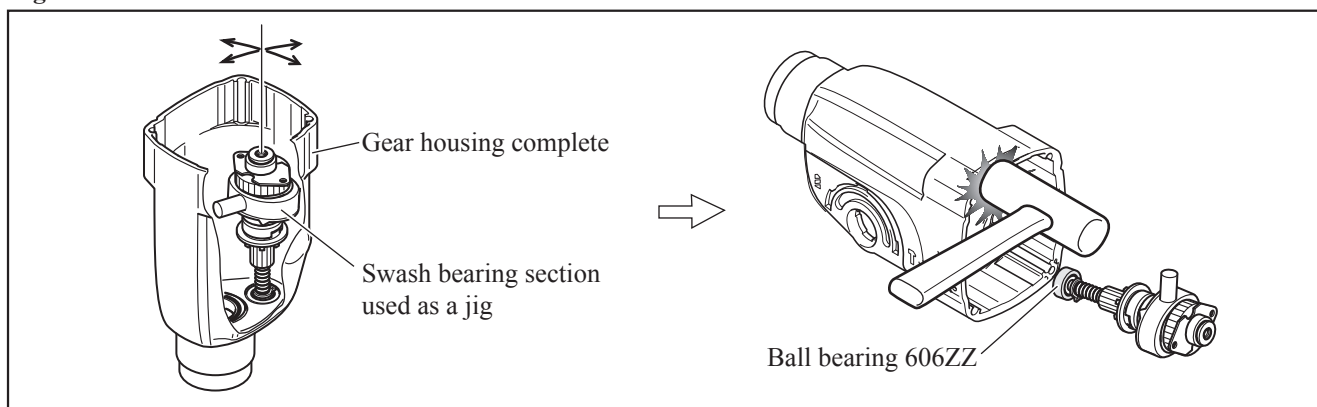

(9) Remove Ring 8 using 1R022, 1R023, 1R281 and arbor press as illustrated in **Fig. 54**.

(10) Remove Ball bearing 608ZZ using 1R269. Flat washer 8 and Bearing retainer can now be removed by hand. (**Fig.55**)

Fig. 54

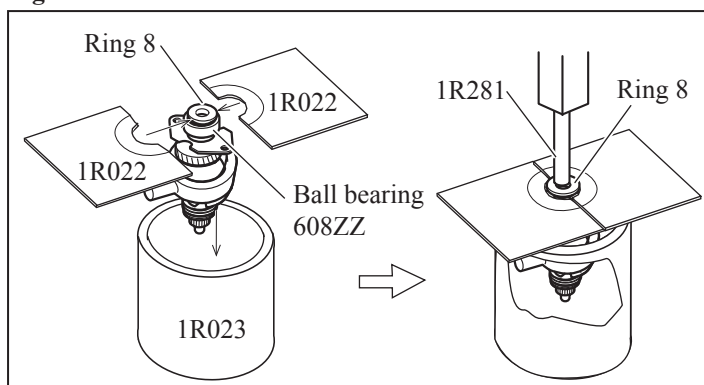
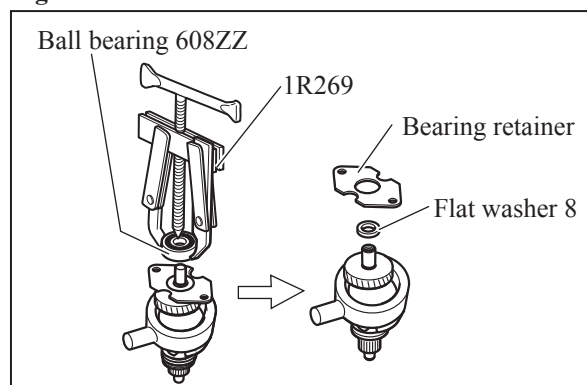

Fig. 55



► **Repair for 3 mode Rotary Hammers HR2470, HR2470F, HR2470T and HR2470FT**

[3] DISASSEMBLY/ ASSEMBLY

[3] -8. Swash Bearing Section (cont.)

DISASSEMBLING

- (11) Remove Helical gear 26 using 1R022, 1R023 and 1R281 as illustrated to left in **Fig. 56**.
Swash bearing 10 and Clutch cam can now be removed by hand (**right in Fig. 57**).
- (12) Remove Retaining ring S-7 using 1R291 (**left in Fig. 57**). Compression spring 7 and Spur gear 10 can now be removed by hand. (**right in Fig. 57**).

Fig. 56

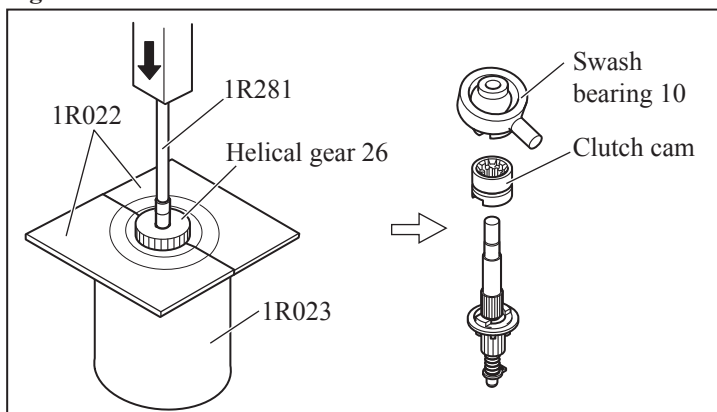
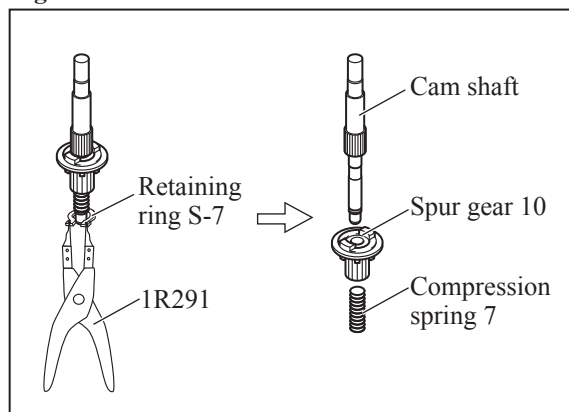

Fig. 57



ASSEMBLING

- (1) Assemble Swash bearing section using 1R032, 1R033, 1R291 and arbor press as illustrated in **Fig. 58**.
Note: Be sure to put Flat washer 8 in place, or else Bearing retainer will be clamped between Ball bearing 608ZZ and Helical gear 26.

Fig. 58

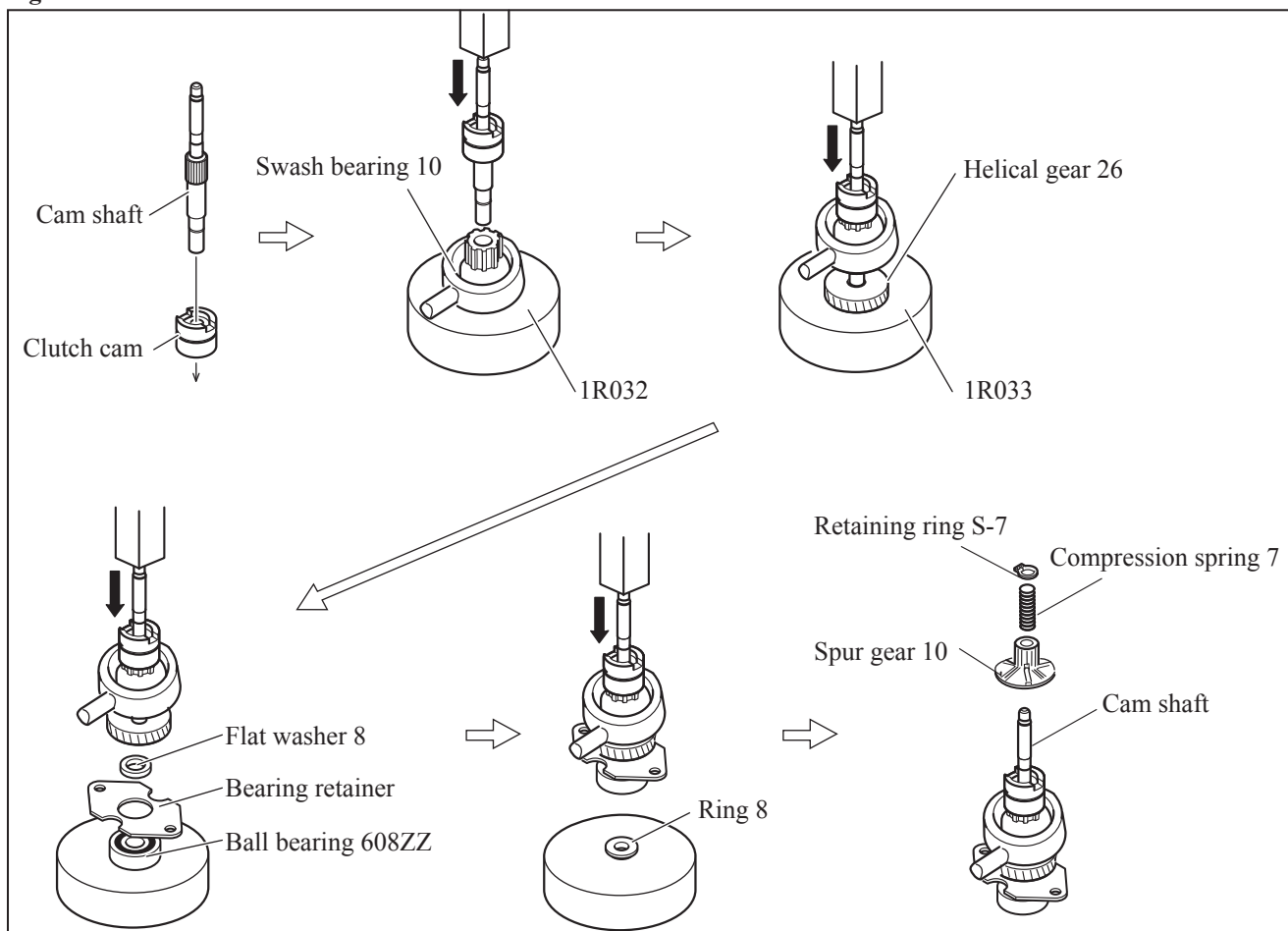

► **Repair for 3 mode Rotary Hammers HR2470, HR2470F, HR2470T and HR2470FT**

[3] DISASSEMBLY/ ASSEMBLY

[3] -8. Swash Bearing Section (cont.)

ASSEMBLING

(2) Assemble Piston joint and two Flat washers 12 to Piston cylinder as illustrated in **Fig. 59**.

Note: Do not forget to apply Makita grease RB No. 00.

(3) Insert Piston cylinder into Inner housing complete. (**Fig. 60**).

Fig. 59

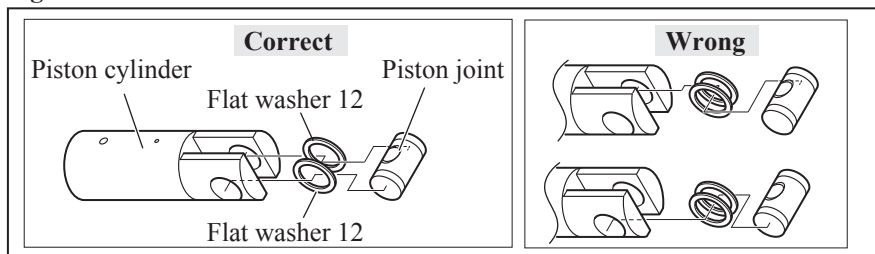
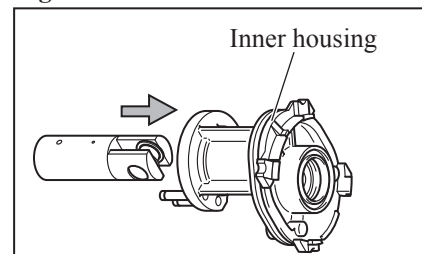

Fig. 60



(4) Move Piston cylinder to the rear dead center position. (**Fig. 61**)

(5) Insert the pole of Swash bearing 10 into the hole of Piston joint as illustrated in **Fig. 62**.

Fig. 61

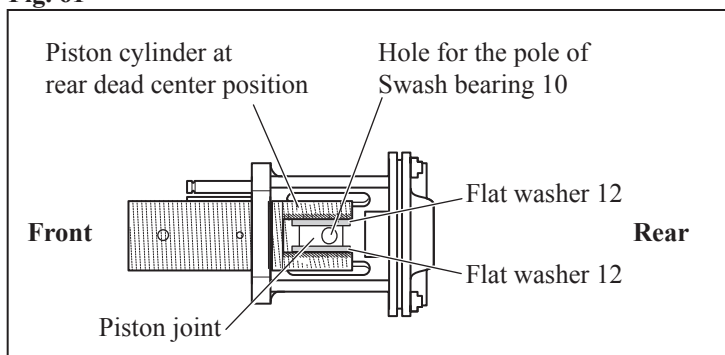
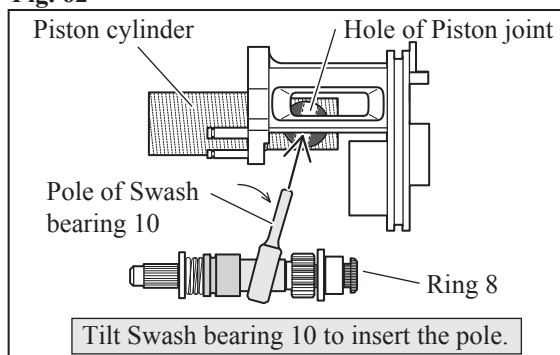

Fig. 62



(6) Insert Ring 8 (the end of Swash bearing section) into Inner housing complete. (**Fig. 63**)

(7) Fitting the tip of Change plate in the groove on Clutch cam, insert Change plate over the pins of Inner housing complete. (**Fig. 64**)

Note: In this step, Ball bearing 608ZZ of Swash bearing section is not yet inserted into Inner housing complete.

Fig. 63

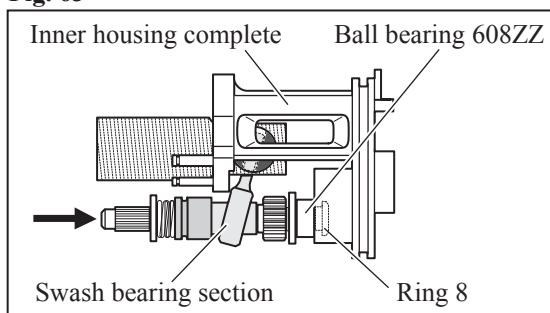
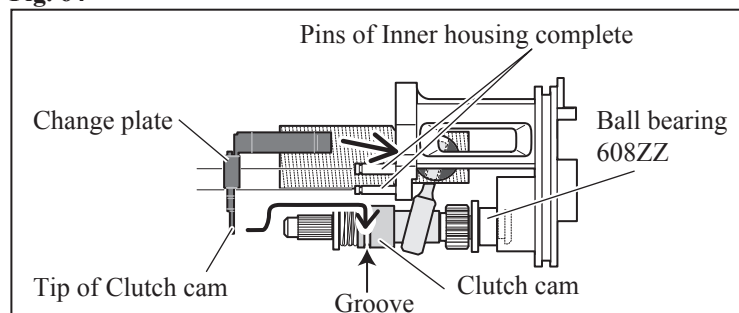
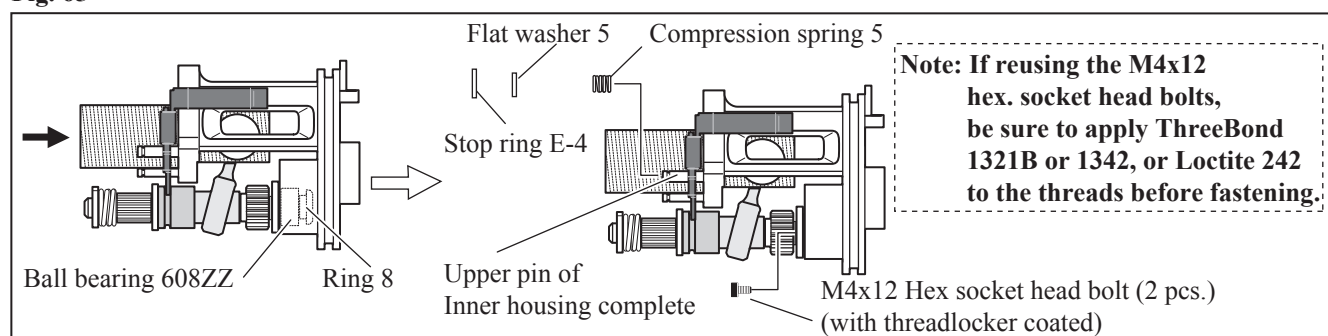

Fig. 64



(8) Insert Ball bearing 608ZZ of Swash bearing section into Inner housing complete, and fasten Swash bearing section to Inner housing complete with two M4x12 hex socket head bolts. Then, put Compression spring 6 and Flat washer 5 through the upper pin of Inner housing complete, and secure them with Stop ring E-4 (**Fig. 65**)

Fig. 65



► **Repair for 3 mode Rotary Hammers HR2470, HR2470F, HR2470T and HR2470FT**

[4] Maintenance Program

When replacing carbon brush, it is recommended to replace the parts listed in the table below at the same time for longer service life of the machine. (Fig. 72)

Fig. 72

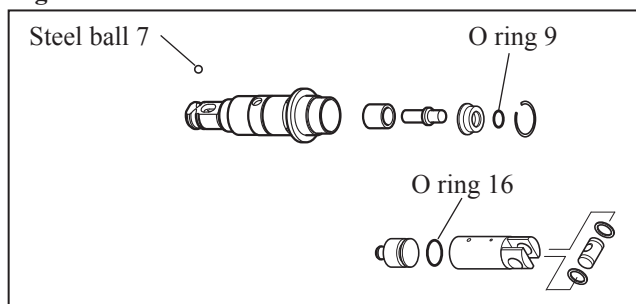

► **Circuit diagram for 3 mode Rotary Hammers HR2470, HR2470F, HR2470T and HR2470FT**

Fig. D-1

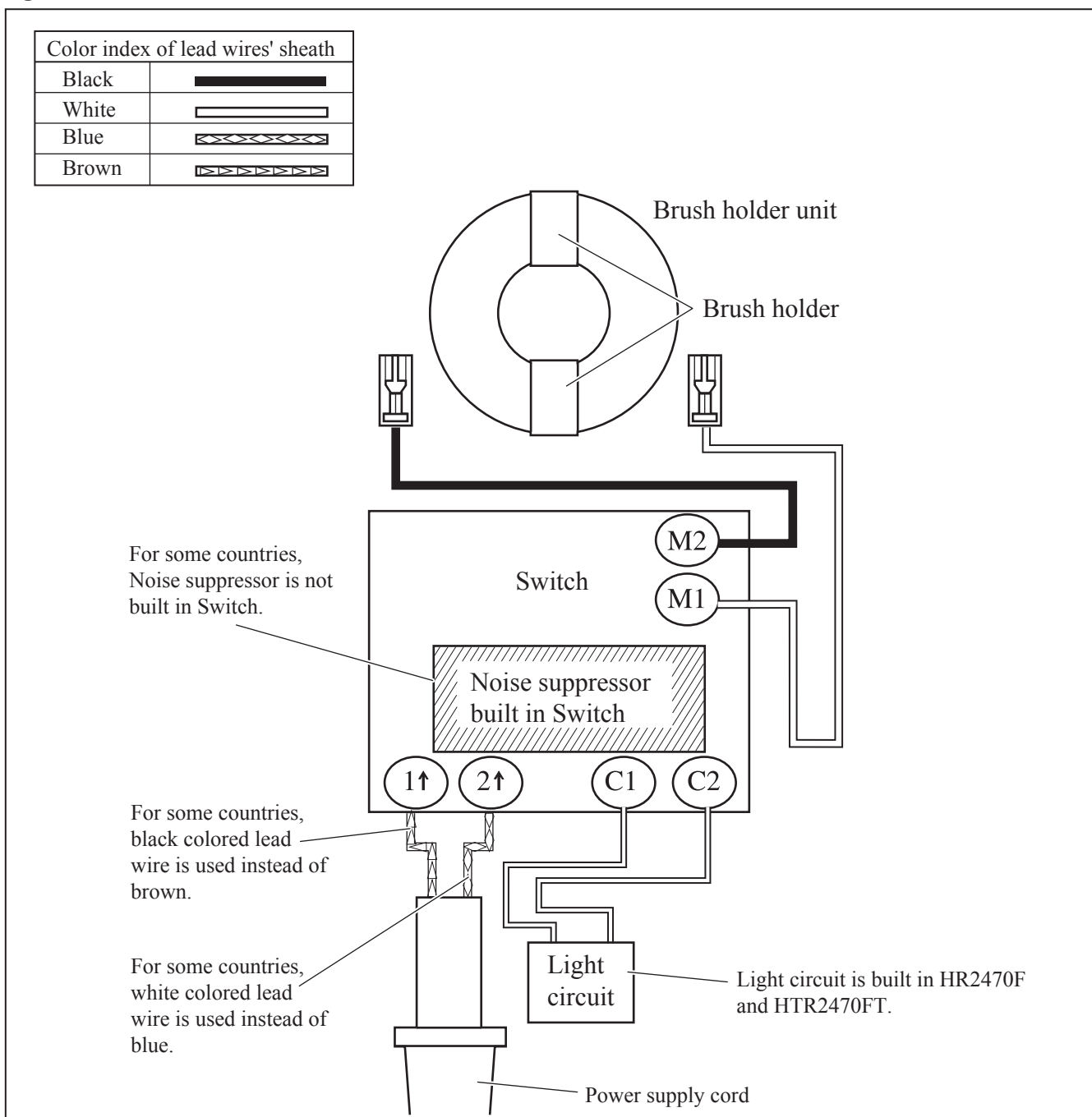

► **Wiring diagram for 3 mode Rotary Hammers HR2470, HR2470F, HR2470T and HR2470FT**

Fig. D-2

