

T ECHNICAL INFORMATION



Models No. ▶ HR2430, HR2431

Description ▶ Rotary Hammer 24mm

CONCEPTION AND MAIN APPLICATIONS

These models are designed mainly for use in dust sensitive environments.

With all the benefits of our existing Model HR2410/HR2420, they feature efficient built-in Dust Extraction System, which is especially convenient in overhead applications.

Model HR2431 is the "D"-handle version of HR2430.

Dimensions : mm (")		
Model No.	HR2430	HR2431
Length (L)	416 (16-3/8)	477 (18-3/4)
Width (W)	70 (2-3/4)	70 (2-3/4)
Height (H)	197 (7-3/4)	156 (6-1/8)
Center Height(CH)	34 (1-5/16)	34 (1-5/16)

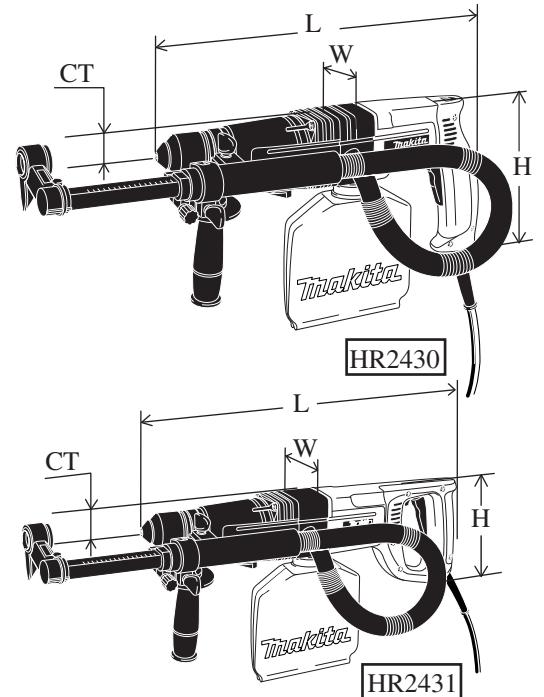

► Specification

Voltage (V)	Current (A)	Cycle (Hz)	Continuous Rating (W)		Max. Output(W)
			Input	Output	
100	7.5(only HR2430)	50 / 60	710	150	550
110	6.8(only HR2430)	50 / 60	710	150	550
120	6.2	50 / 60	710	150	550
230	3.2	50 / 60	710	200	600

No load speed	: (min -1= rpm)	0 - 1,050
Blows per min.	: (min -1= bpm)	0 - 4,900
Bit type		SDS-plus 10mm (3/8") in dia.
Drilling capacity : mm (")	in Steel	13 (1/2)
	in Wood	32 (1-1/4)
	in Concrete	24 (15/16) HR2430 for Canada : 25 (1) HR2431 for U.S.A. : 25 (1)
Reversible switch		Available
Net weight : Kg (lbs)		HR2430 : 2.6 (5.7) HR2431: 2.8 (6.2)
Cord length : m (ft)		2.5 (8.2)

► Standard equipment

Plastic carrying case	1 pc.	Dust extraction fixture.....	1 pc.
Grease for bit	1 pack.	Hose	1 pc.
Cap	1 pc.	Dust bag	1 pc.

< Note > The standard equipment for the tool shown may be differ from country to country.

► Optional accessories

T.C.T. drill bit 4.0 - 24 mm (5/32" - 15/16")	Grease vessel
Drill chuck assembly	Blow out bulb
Chuck key S13	Depth gauge
Anchor setting tool	Cuff 19-25
Anchor setting rod No.2, No.2.5, No.3, No.4	

► Repair

<1> Removing chuck section

- 1) Pull down chuck cover and remove cap 31. And then, remove chuck cover and compression spring 38 as illustrated in Fig.1.

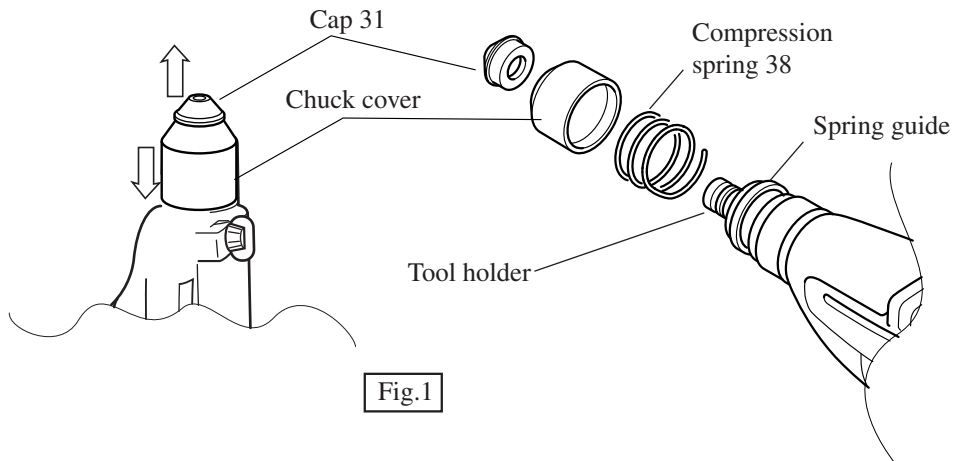

- 2) Remove ring spring 17. (See Fig.2.)
- 3) Remove ring spring 30.5 from chuck ring, and then, remove spring guide and compression spring 35. (See Fig.2)
- 4) Take off leaf spring 26. And then, remove pin 8 from chuck ring. (See Fig.2)
Leaf spring 26 can be removed easily by expanding it with retaining ring plier for shaft .
- 5) Remove chuck ring , guide washer and steel ball 7.0 from tool holder. (See Fig.2)

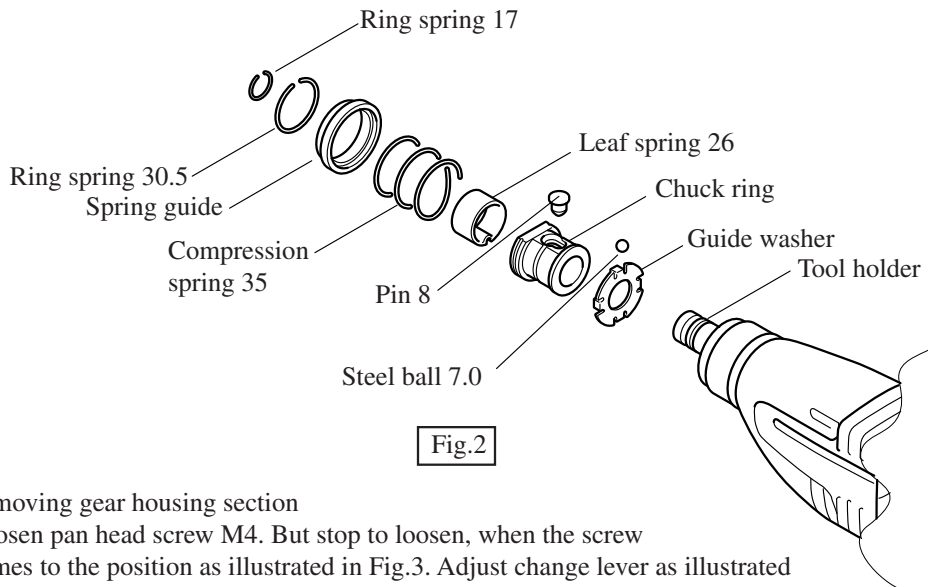

<2> Removing gear housing section

Loosen pan head screw M4. But stop to loosen, when the screw comes to the position as illustrated in Fig.3. Adjust change lever as illustrated in Fig.3A and pull out it from gear housing.

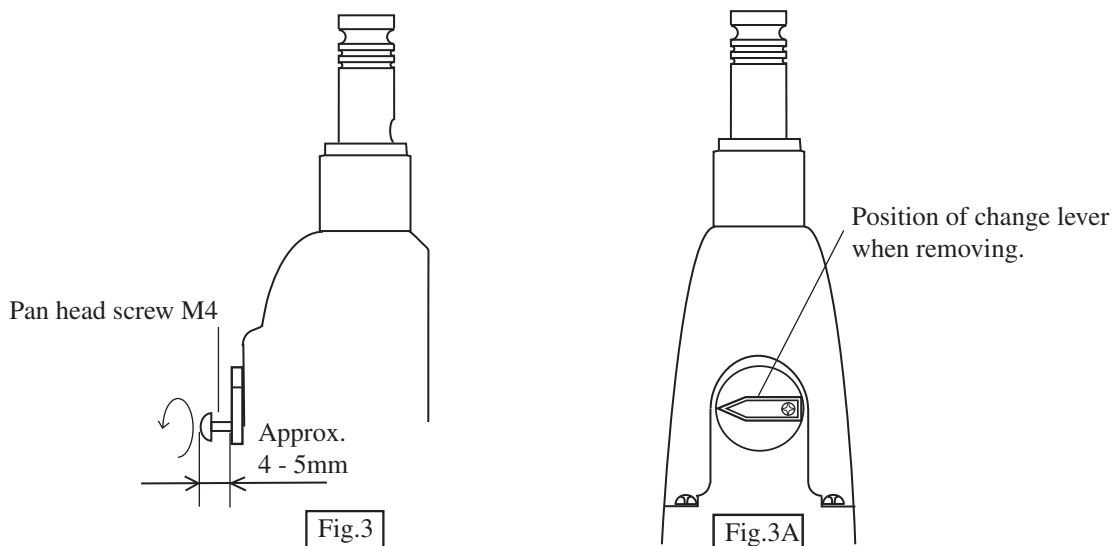

► Repair

Remove tool holder with arbor press as illustrated in Fig.4.

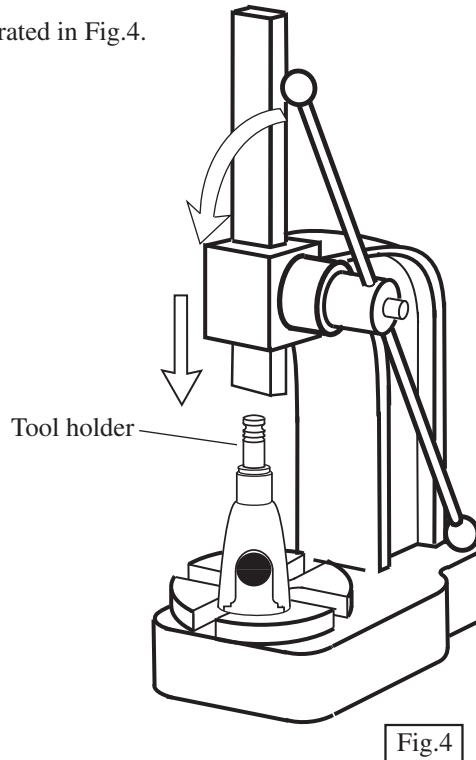

<3> Removing impact bolt

1. Push impact bolt ahead with screwdriver as illustrated in Fig.5.

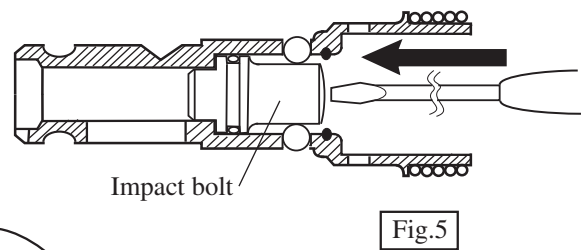

2. Take off steel ball 5.6 by striking stool holder with plastic hammer slightly as illustrated in Fig.5A

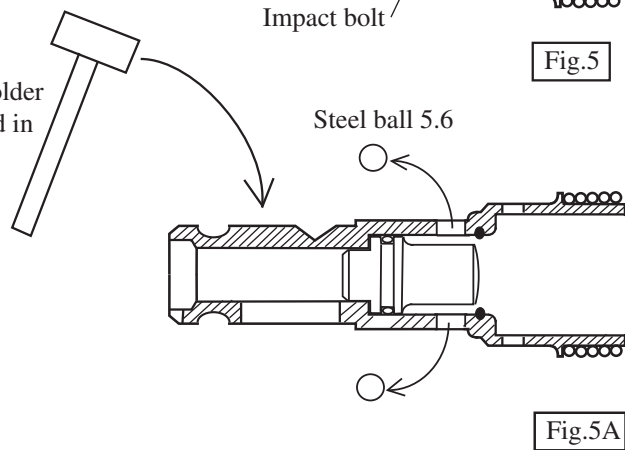

3. Take off O ring 11 with a bodkin as illustrated in Fig.5B.

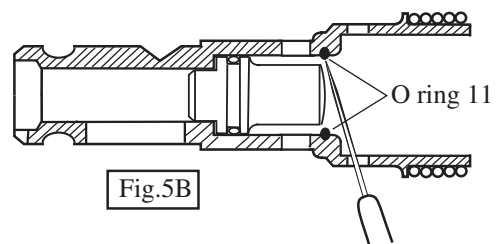

4. Remove impact bolt by pushing it with screwdriver as illustrated in Fig.5C.

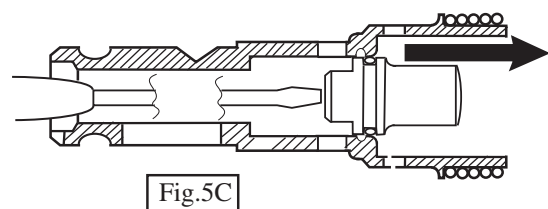

► Repair

<4> Removing crank section

A. Removing piston cylinder

Shift piston cylinder to tool holder side by turning crank shaft as illustrated in Fig. 6. Take off pin 6 with screwdriver from piston cylinder.

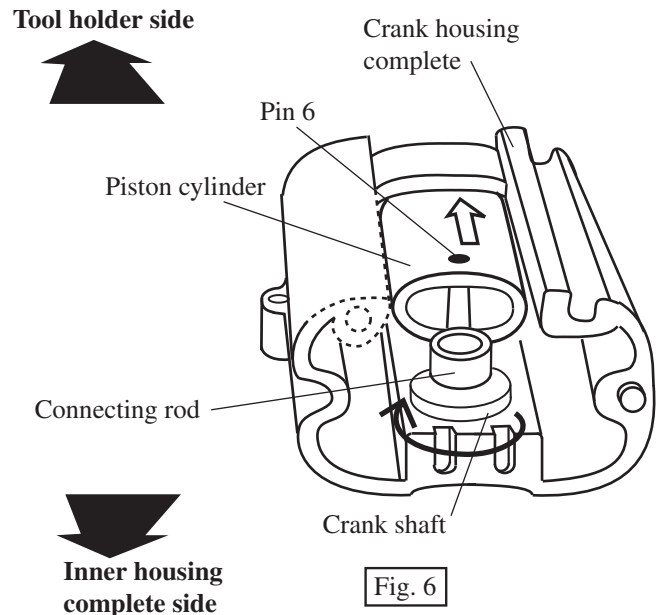

Fig. 6

B. Removing connecting rod

Remove inner housing complete from crank housing complete by taking off pan head screw M4x50 (3 pcs.).

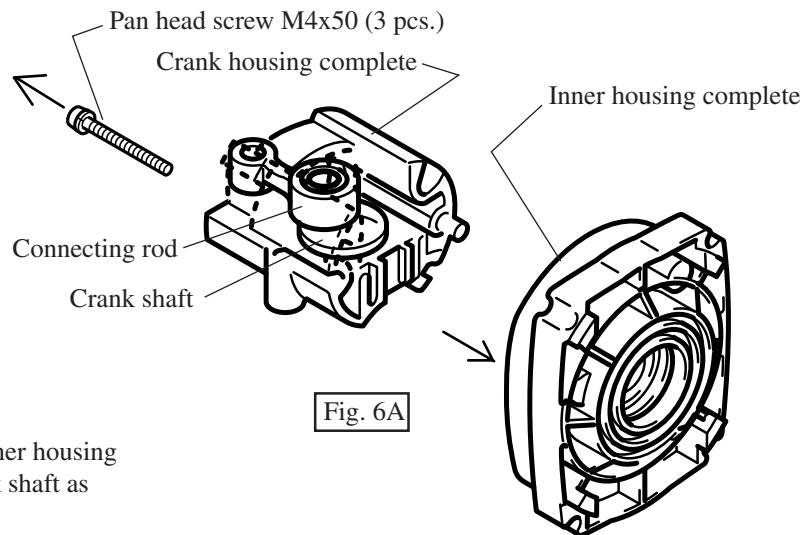

Fig. 6A

Bring connecting rod to the inner housing complete side by turning crank shaft as illustrated in Fig. 6B.

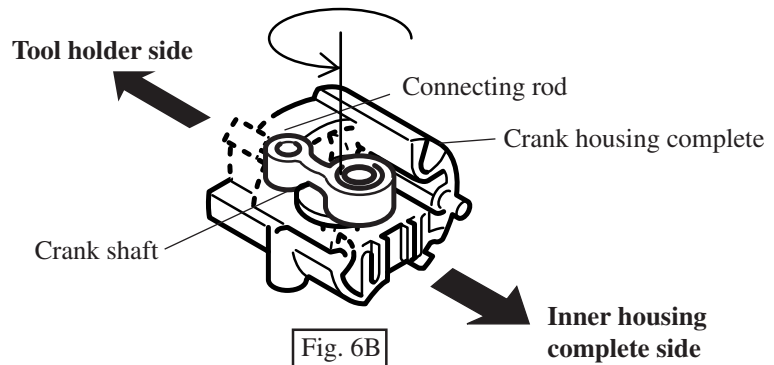

Fig. 6B

Hold the inner housing complete side of connecting rod. And take off connecting rod by lifting its tool holder side as illustrated in Fig. 6C.

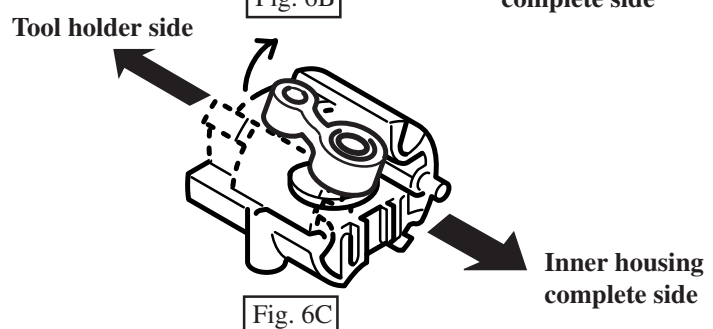

Fig. 6C

► Repair

C. Removing helical gear 31, straight bevel gear 14 and clutch cam

Take off pan head screw M4x16 (2 pcs.) from crank housing complete. And then, remove gear cover and the unit of spur gear 10 as illustrated in Fig.6D.

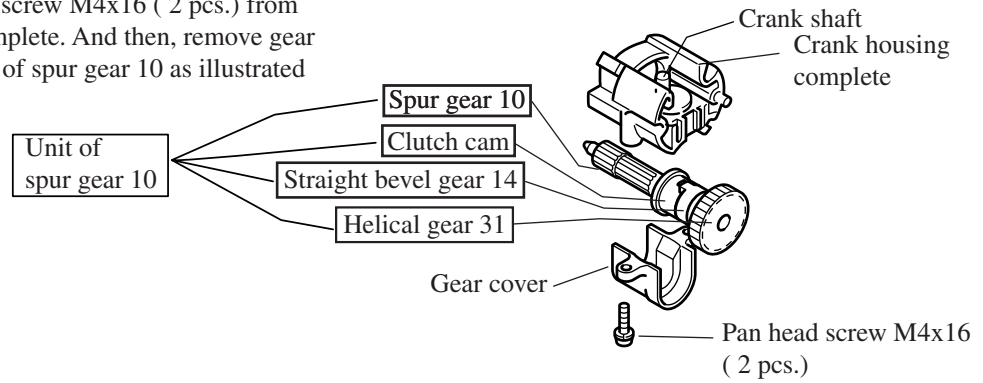

Fig.6D

Remove helical gear 31 by pressing it with arbor press.

And then, the spare parts on spur gear 10 can be removed as illustrated in Fig.6E.

(It is recommended to use round bar for arbor No.1R235 6mm in dia., when removing with arbor press.)

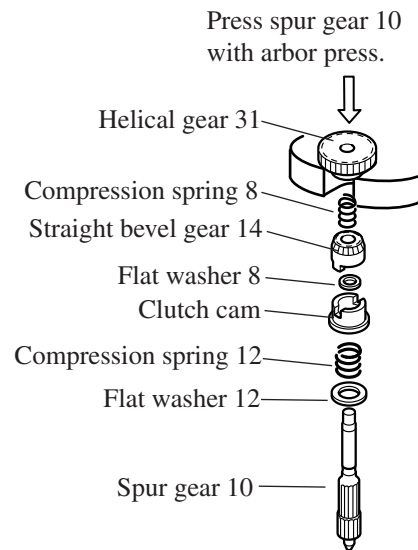

Fig.6E

D. Removing crank shaft

Set crank housing complete on No.1R215: block A for crank housing and set No.1R234:round bar for arbor 5mm in dia. on crank shaft.

Remove crank shaft by pressing the round bar for arbor with arbor press.

< Note > No.1R215 block A has to be set, paying attention to the position of its wide surface as illustrated in Fig.6F.

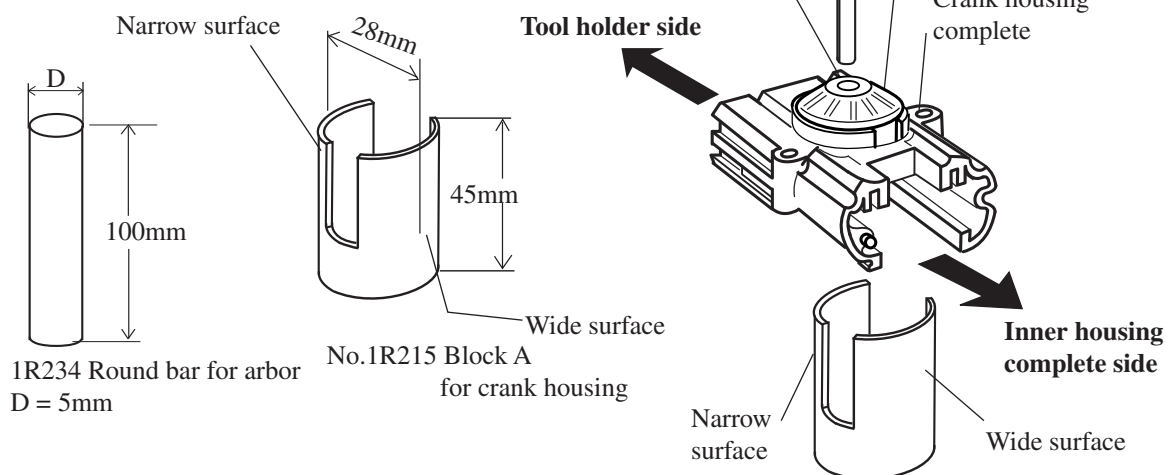

Fig.6F

► Repair

<5> Removing armature section

- 1) Remove brush holder from motor housing after taking off handle cover as illustrated in Fig 7.
- 2) Remove fan housing from motor housing as illustrated in Fig 7.

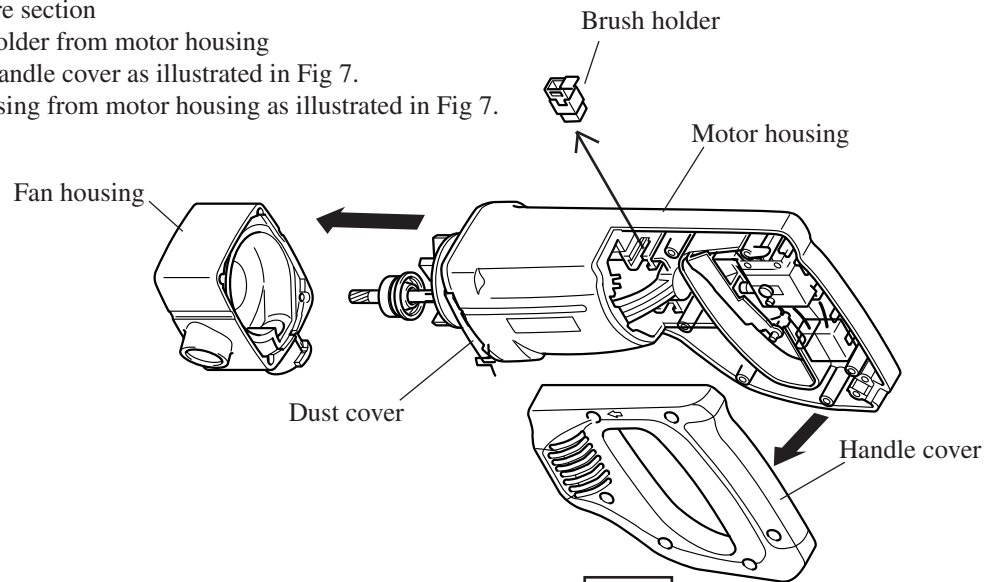

Fig. 7

- 3) Remove armature assembly together with dust cover and fan 56 as illustrated in Fig 7A.

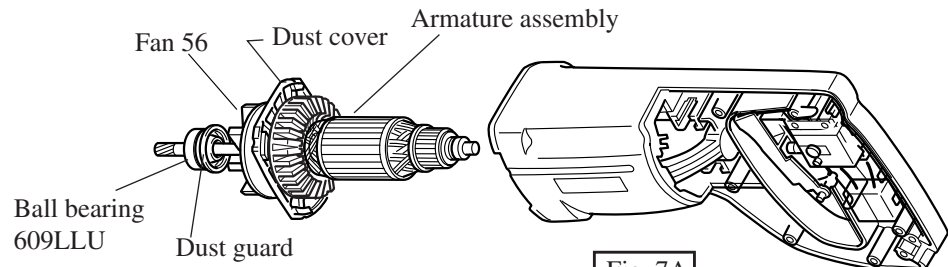

Fig. 7A

- 4) Remove dust guard and ball bearing 609LLU from armature assembly. And then, remove retaining ring S-10 as illustrated in Fig 7B.

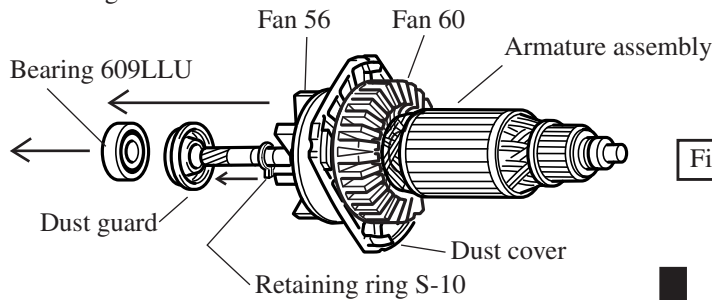

Fig. 7B

- 5) Set armature unit (fan 56, dust cover and fan 60) on the 2 V-blocks. And remove fan 56 (aluminum made) and dust cover by pressing armature shaft. Then armature can be separated together with ball bearing 6000LLU, flat washer 8 and fan 60, from fan 56 and dust cover.

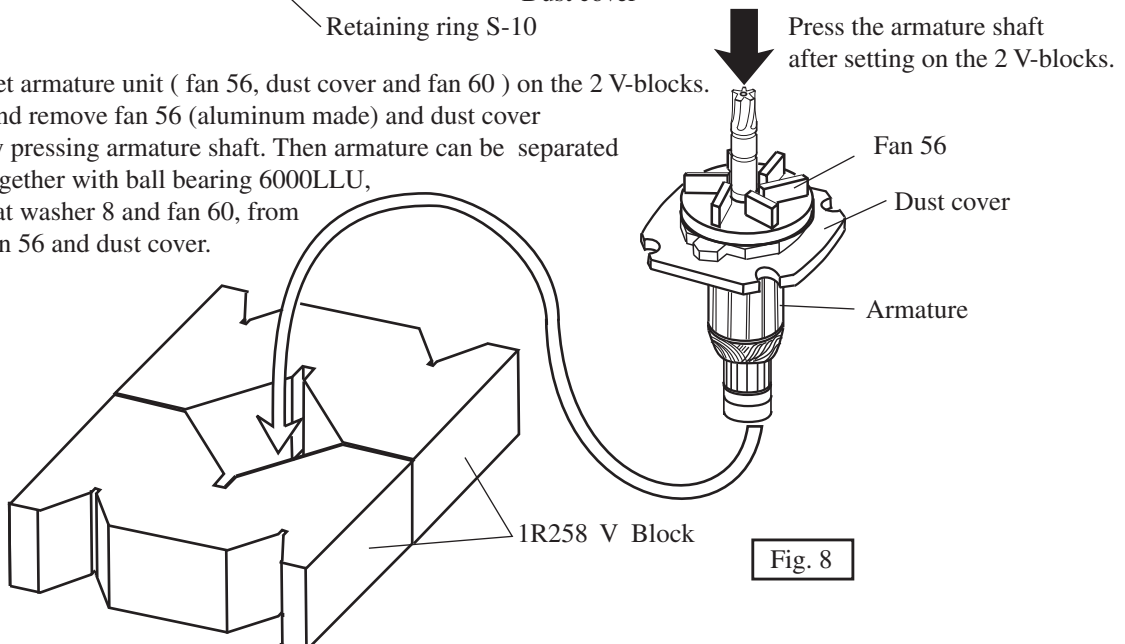

Fig. 8

▶ Repair

- 6) Hold fan 60 with No.1R022 bearing extractor plate, and remove ball bearing 6000LLU, fan 60 and flat washer 10 by pressing armature shaft slowly as illustrated in Fig.9.

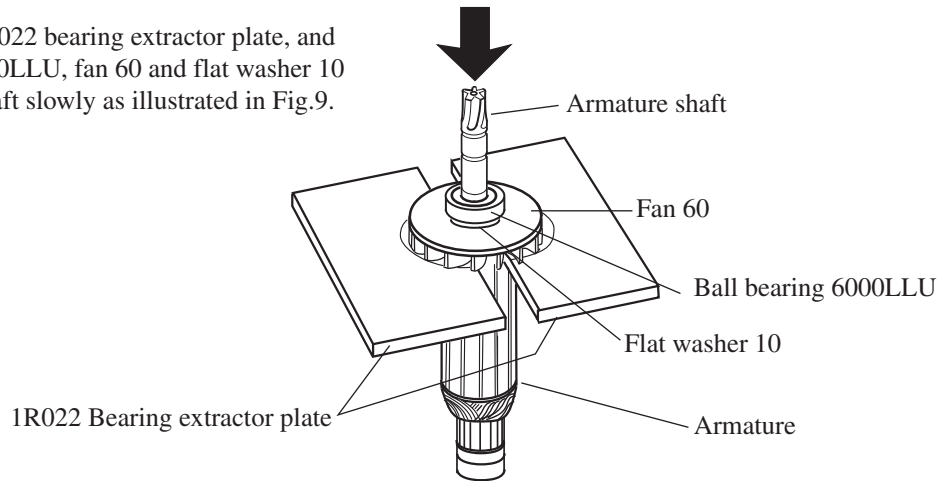
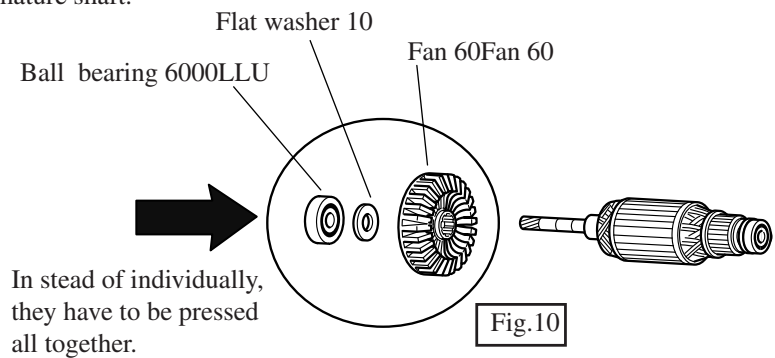

Fig.9

<6> Assembling armature

- (1) Press fan 60, ball bearing 6000LLU and flat washer 10 all together on armature shaft as illustrated in Fig.10. Not press them individually on armature shaft.



In stead of individually, they have to be pressed all together.

Fig.10

- (2) Press dust cover. And then, press flat washer 10 as illustrated in Fig.11. Apply MAKITA grease N No.2 in advance approx. by 1g. on the flat washer's surface which contacts with ball bearing 6000LLU.

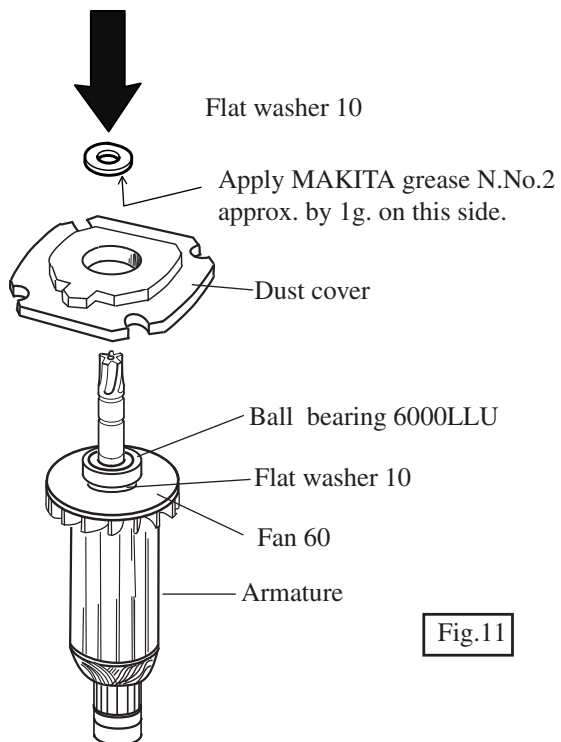

Fig.11

- (3) Press fan 56 as illustrated in Fig.12.

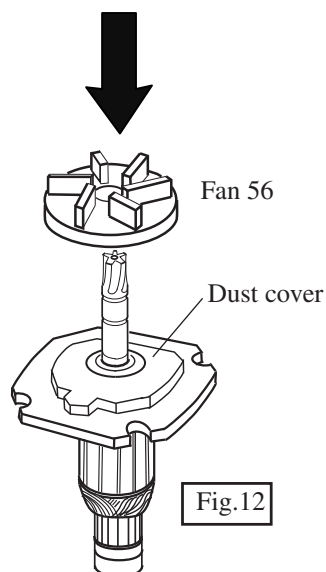

Fig.12

► Repair

- (4) Assemble retaining ring S-10. And then, press dust guard and ball bearing 609LLU as illustrated in Fig.13.

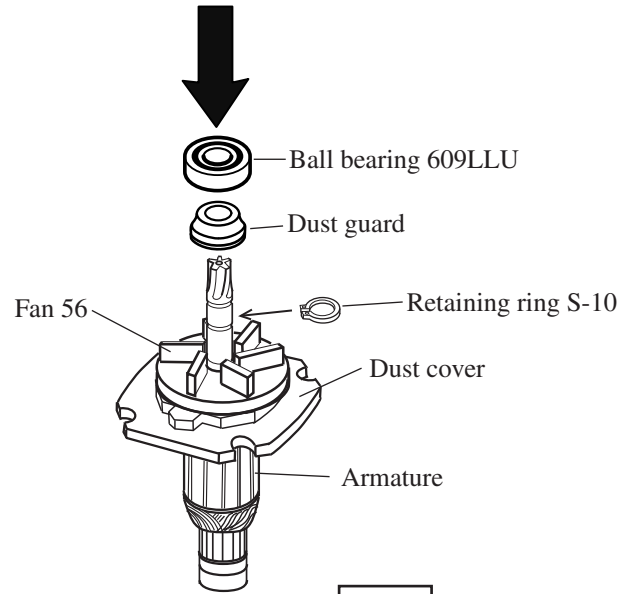

Fig.13

<7> Assembling fan housing section to armature section

- (1) Assemble dust proof sheet to fan housing.
Pay attention to the face of dust proof sheet in order to set it in the groove of fan housing.
- (2) Press plate slightly into the fan housing's groove for assembling plate through dust proof sheet.
- (3) Assemble fan housing section to armature section.

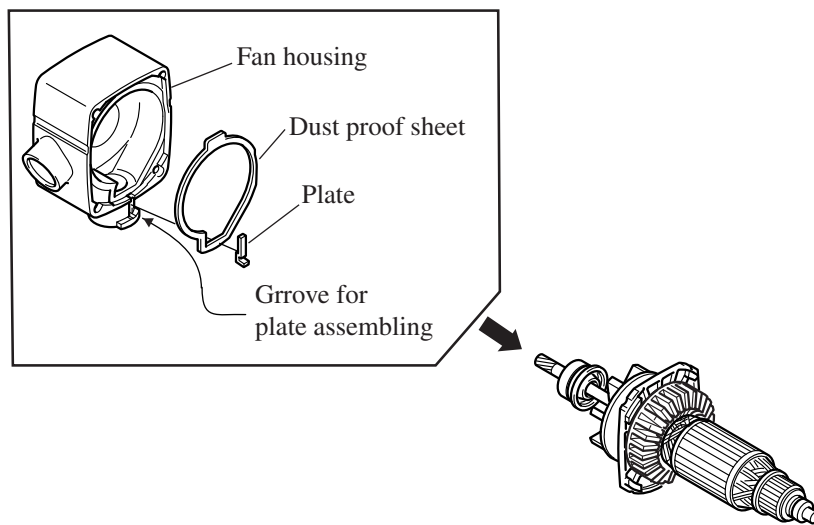
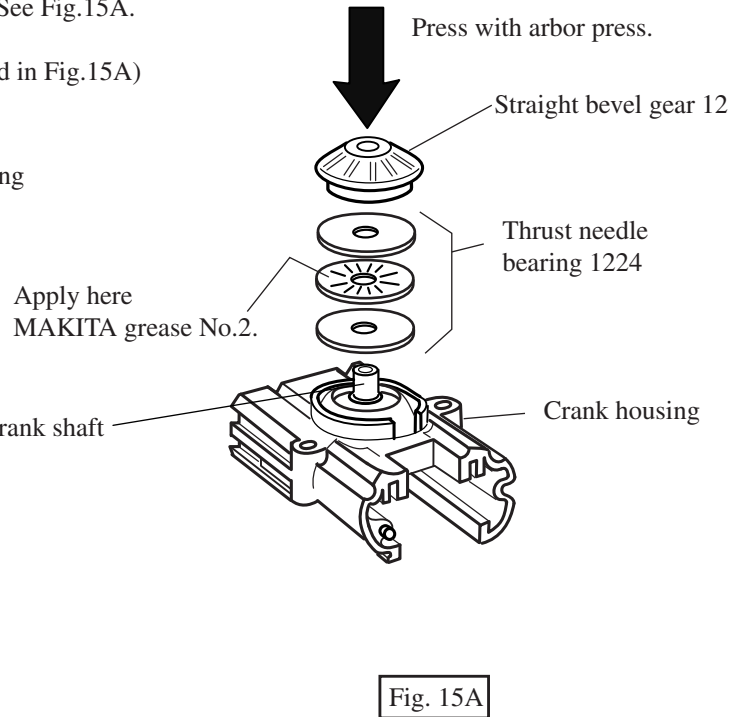
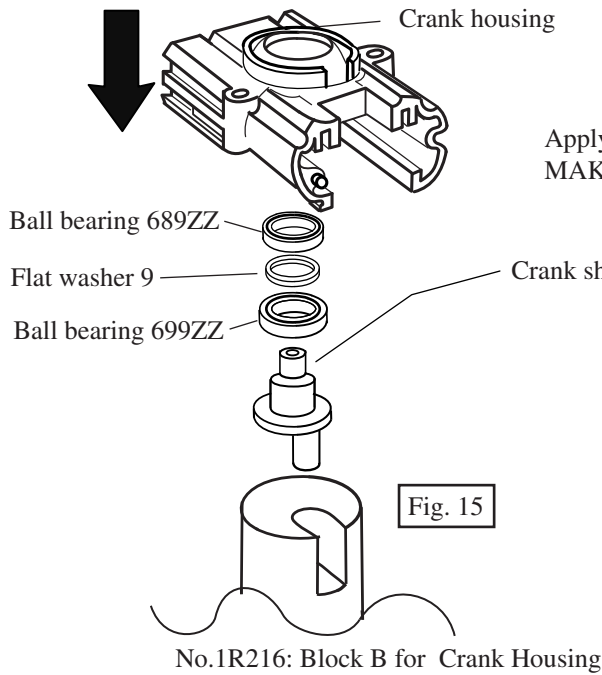

Fig.14

▶ Repair

<8> Assembling crank section

- 1) Assemble the following parts to crank shaft with No.1R216 Block B for crank housing. See Fig.15.
 - * Ball bearing 689ZZ
 - * Flat washer 9
 - * Ball bearing 699ZZ
- 2) Assemble the above crank shaft to crank housing. See Fig.15.
- 3) Assemble the following parts to crank shaft which has been assembled to crank housing. See Fig.15A.
 - * Thrust needle bearing 1224
 - (Apply MAKITA grease No.2 as illustrated in Fig.15A)
 - * Straight bevel gear 12



<9> Assembling impact bolt

- 1) Insert impact bolt into tool holder with screwdriver as illustrated in Fig.16A. When inserting it, the short head side of impact bolt has to be faced to the bit side.

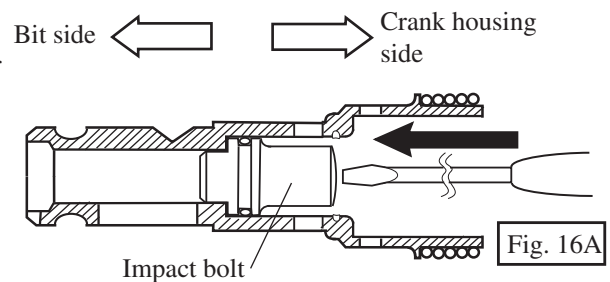

- 2) Assemble O ring 11 into the groove of tool holder with finger as illustrated in Fig.16B.

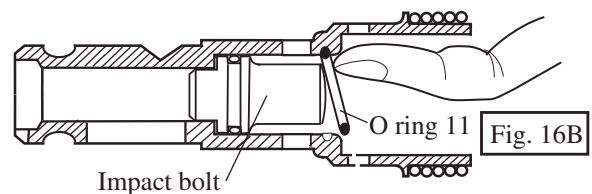

- 3) Assemble steel ball 5.6 to the hole of tool holder with finger as illustrated in Fig.16C. And then, apply grease to steel ball 5.6 and the hole of tool holder for easy assembling tool holder to the machine without losing steel ball 5.6.

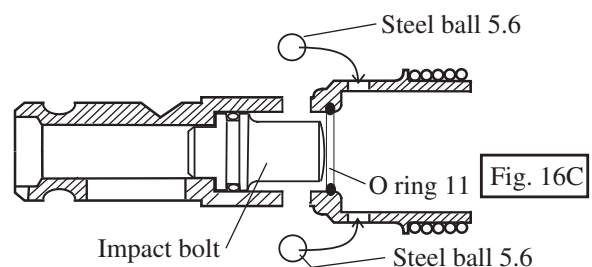

► Repair

<10> Assembling gear housing section

1) Press the tool holder unit into gear housing complete with arbor press as illustrated in Fig.17.

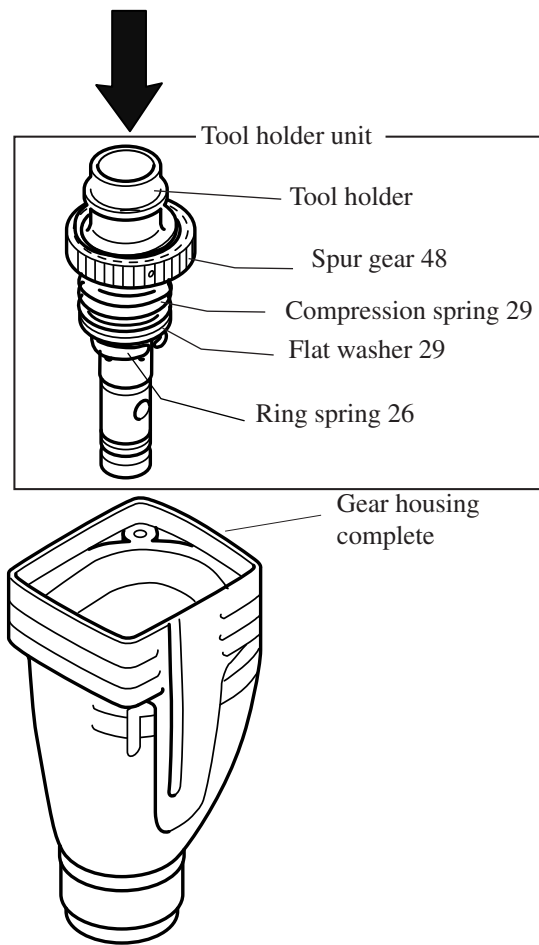

2) Assemble change lever to gear housing complete. Change lever has to be adjusted as illustrated in Fig.18 when assembling.

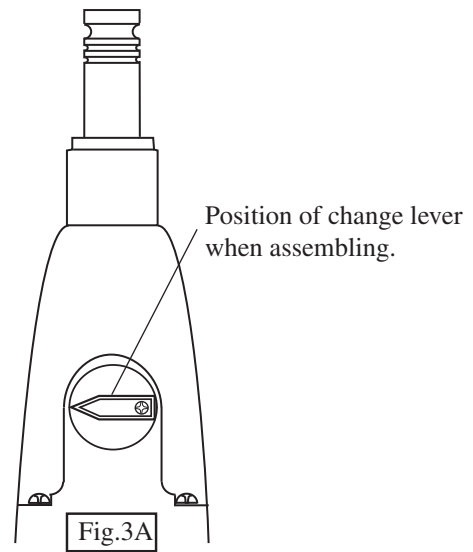

<11> Lubrication

Apply grease on the following places in order to protect parts and machine from usual abrasion and overheating. Recommendable is our genuine grease, MAKITA Grease R No1.

(1) O ring on impact bolt and the groove on impact bolt for O ring assembling

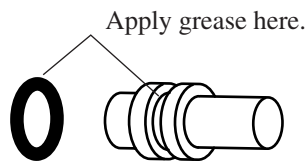

(2) O ring on striker and the groove on striker for O ring assembling

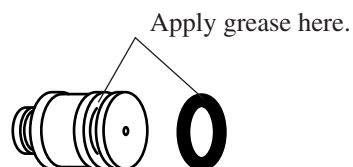

(3) Inner part, surface and groove of piston cylinder, and pin 6's surface

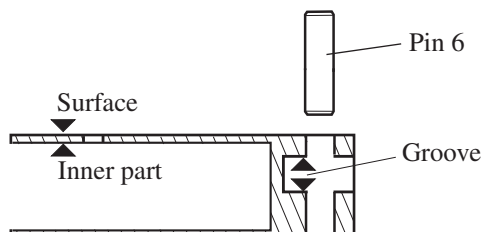

► Repair

(4) Teeth of spur gear 10

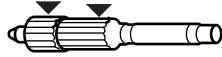

(5) Clutch cam, flat washer 8 and straight bevel gear 14

Clutch cam

Flat washer 8

Straight bevel gear 14

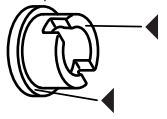

Inner part

(6) Flat washer 27



(7) Oil seal 20

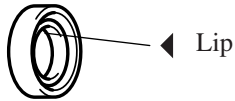

Lip

(8) Gears

Spur gear 48

Straight bevel gear 12

Helical gear 31



(9) Needle bearings

Needle bearing 810
assembled to crank shaft

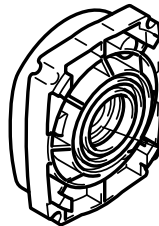

Needle bearing 709 assembled
in inner housing



► Circuit diagram

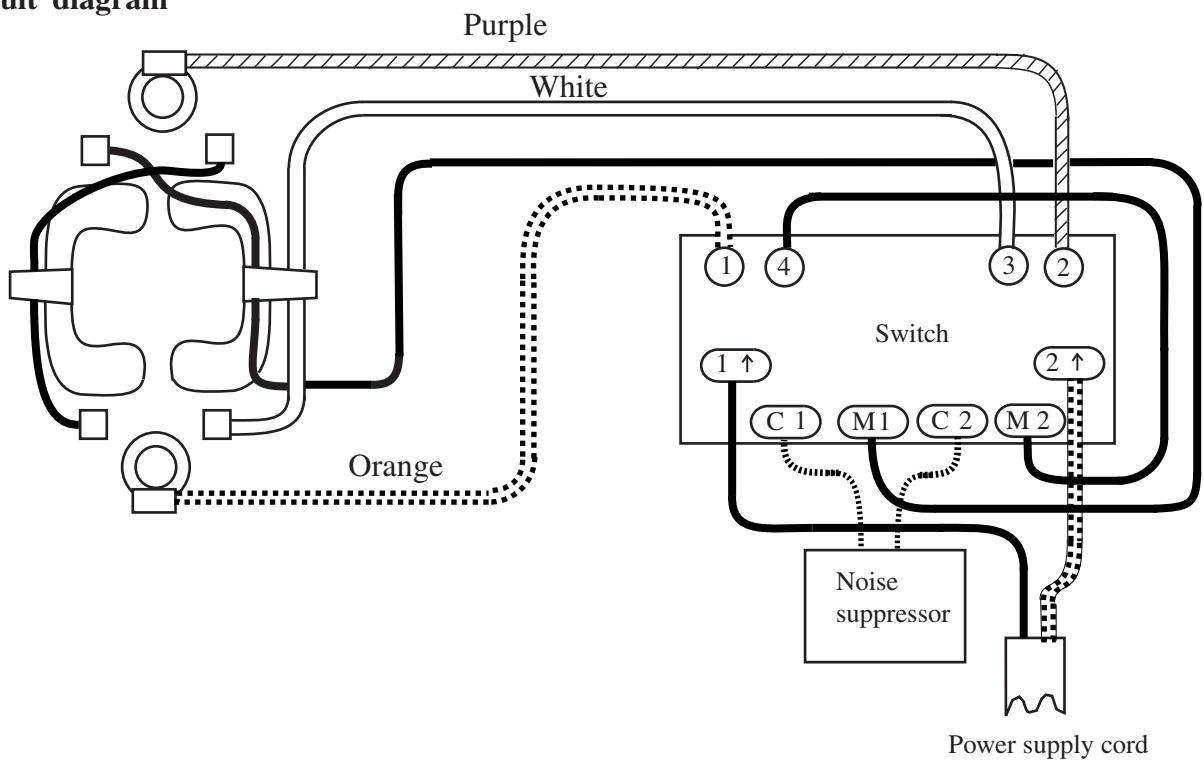

► Wiring diagram

Lead wire (purple) between reversible switch and brush holder has to be passed through the space between rib and inner wall.

Lead wire (black) between reversible switch and main switch (ON - OFF) has to be passed through back of the rib.

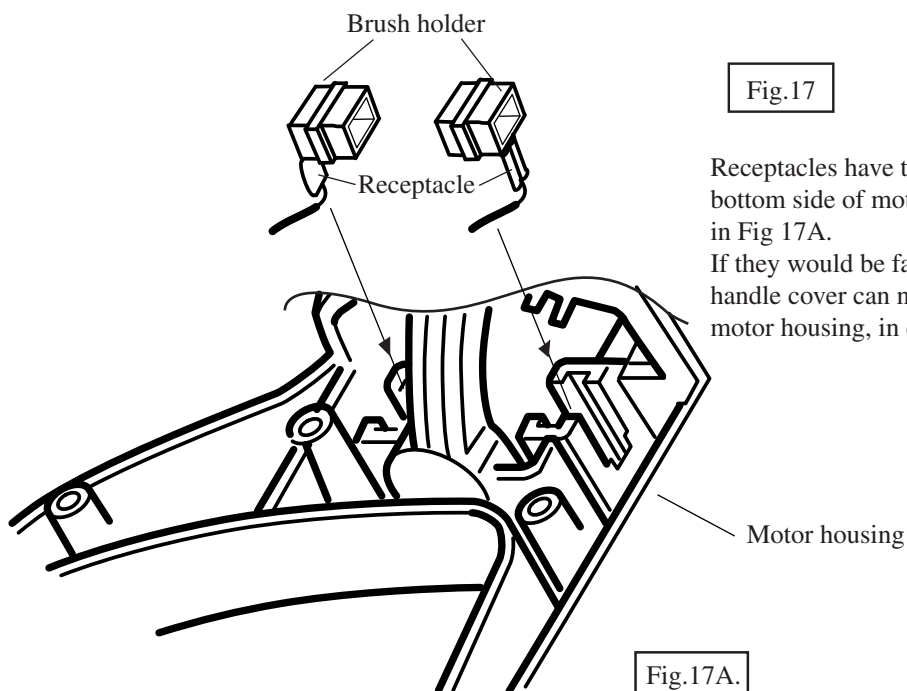
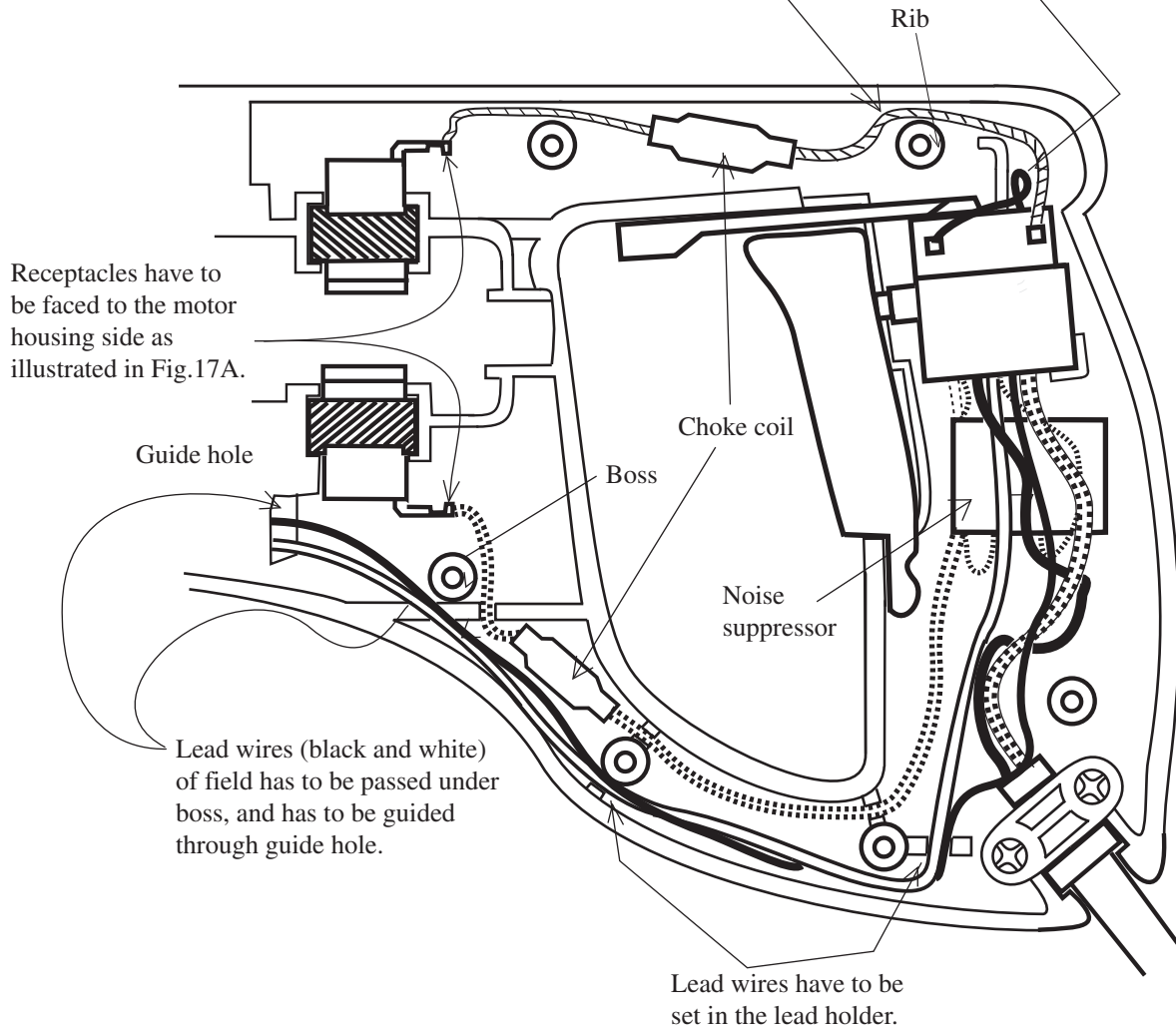

Fig.17

Receptacles have to be faced to the bottom side of motor housing as illustrated in Fig 17A.

If they would be faced to handle cover side, handle cover can not be assembled to motor housing, in case may be.

Fig.17A.