

# TECHNICAL INFORMATION



NEW TOOL

P 1 / 13

**Models No.** ▶ HP2070, HP2070F, HP2071, HP2071F

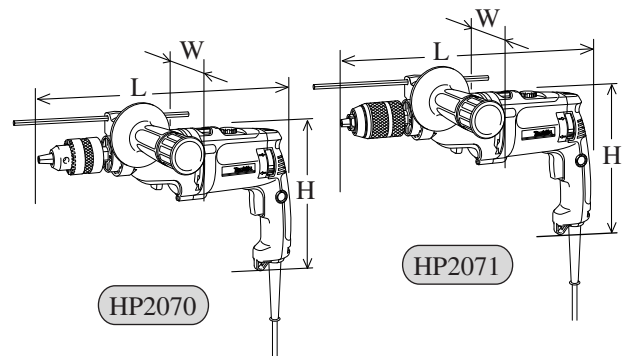
**Description** ▶ 20mm (3/4") 2-Speed Hammer Drill

## CONCEPT AND MAIN APPLICATIONS

These hammer drills have been developed as the highest specification models of Makita hammer drills.

Their features are;

- \* Powerful 1,010W motor
- \* New reversing system prevents the speed reduction of motor in reverse rotation.
- \* Mechanical 2 speed, and electronic speed adjusting dial for presetting maximum speed
- \* LED job light convenient for operations at dimly lit job sites (HP2070F and HP2071F)
- \* Keyless drill chuck (HP2071 and HP2071F)



Dimensions : mm [inch]	
Length ( L )	362 [14-1/4]
Height ( H )	220 [8-5/8]
Width ( W )	70 [2-3/4]

## ► Specification

Voltage (V)	Current (A)	Cycle (Hz)	Continuous Rating (W)		Max. Output (W)
			Input	Output	
110	9.7	50 / 60	1,010	600	1,100
120	8.2	50 / 60	940	600	1,100
220	4.8	50 / 60	1,010	600	1,100
230	4.6	50 / 60	1,010	600	1,100
240	4.4	50 / 60	1,010	600	1,100

Model No.		HP2070	HP2070F	HP2071	HP2071F
No load speed (min -1= rpm)	High	0 - 2,900			
	Low	0 - 1,200			
Blows per min. (min -1= bpm)	High	0 - 58,000			
	Low	0 - 24,000			
Drill chuck		Keyed		Keyless	
Chuck ability (mm [inch])		2.0 - 13 [1/16 - 1/2]			
Drilling capacity (mm [inch])	Concrete		20 [13/16]		
	Steel	High	8 [5/16]		
		Low	16 [5/8]		
	Wood	High	25 [1]		
Low		40 [1-9/16]			
Reverse switch		Yes			
Mechanical speed change		2 speed			
Torque limiter		Yes			
LED Job light		No	Yes	No	Yes
Protection against electric shock		by double insulation			
Cord length (m [ft])		2.5 [8.2]			
Net weight (kg [lbs])		2.4 [5.3]			

## ► Standard equipment

- \* Depth gauge ..... 1 pc.
- \* Side handle set ..... 1 set
- \* Plastic carrying case ..... 1 pc.
- \* Chuck key S13 (HP2070 and HP2070F) .... 1 pc.
- \* Key holder (HP2070 and HP2070F) ..... 1 pc.

< Note >

The standard equipment for the tool may differ from country to country.

## ► Optional accessories

- \* T.C.T. drill bits Ø 5.0 - Ø 19.0
- \* Drill bits for steel Ø 5.0 - Ø 13.0
- \* Drill bits for wood Ø 5.0 - Ø 40.0
- \* Hole saws Ø 16 - Ø 120
- \* Metal borer Ø 14 - Ø 35
- \* Chuck key S13 for HP2070 and HP2070F

- \* Depth gauge
- \* Wrench
- \* Blow out bulb
- \* Keyless drill chuck set
- \* Drill chuck set
- \* Side handle set
- \* Drill stand type 43

## ► Repair

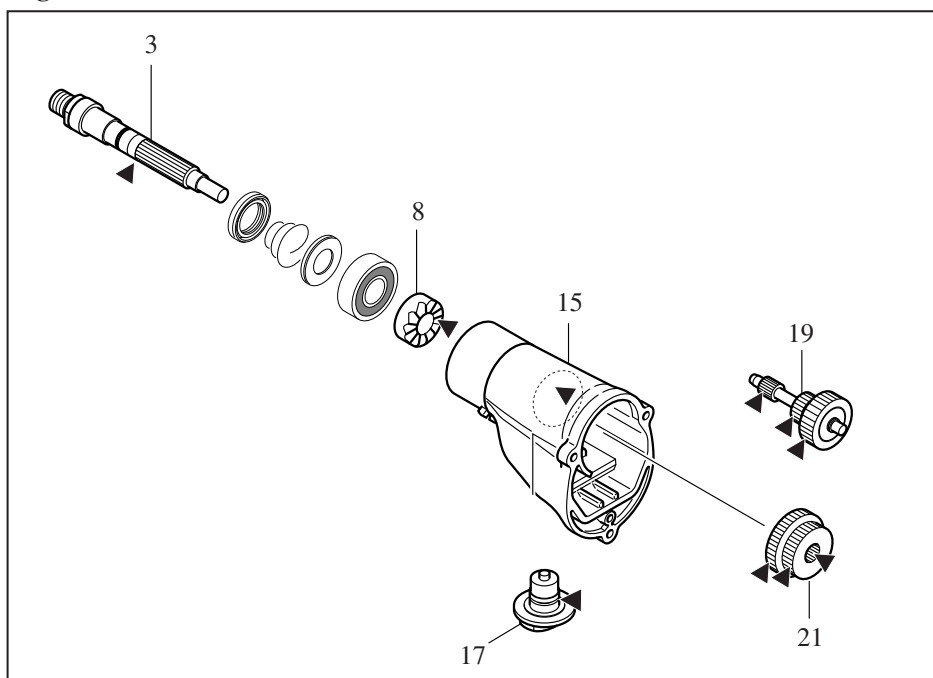
### <1> Lubrication and Adhesive Application

#### • Lubrication

Apply Makita grease N No.1 to the following portions designated by the black triangular mark to protect the parts and the tool from unusual abrasion. (Fig.1)

Item No. in parts breakdown	Part name	Portion to lubricate	Amount (g [oz])
3	Spindle	Whole surface except threaded portion	Proper amount
8	Cam A		
15	Gear housing complete	Gear chamber	approx. 25 [7/8]
17	Change lever	Teethed portion	Proper amount
19	Gear complete	Teeth	
21	Spur gear 29-37	Teeth	

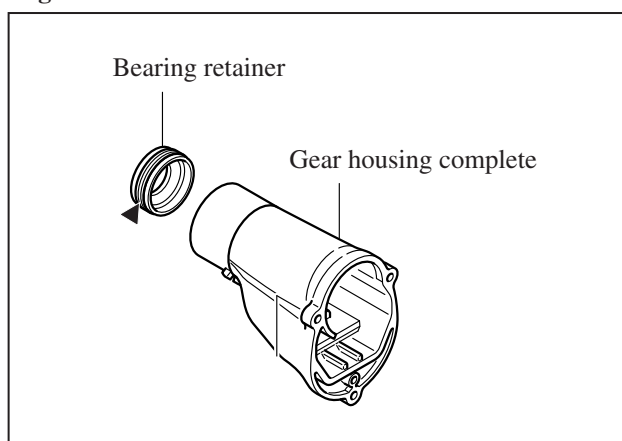
Fig. 1



#### • Adhesive Application

Apply TREE BOND 1327 to the threaded portion of Bearing retainer when fastening Bearing retainer to Gear housing complete. (Fig.2)

Fig. 2



<2> Disassembling and Reassembling Procedures

1) Drill Chuck

Disassembly;

- 1) Secure a Drill chuck extractor (1R139) firmly with a vise as illustrated in Fig. 3.
- 2) Fix the Spindle on the Drill chuck extractor by inserting the Spindle into the U-shaped notch on the Drill chuck extractor with the flat sides of the Spindle facing the edges of the notch. And then remove the Drill chuck by turning it counterclockwise with the repairing tools (1R223, 1R224 and 1R298). (Fig. 4)
  - Use a pipe wrench to remove the Drill chuck, if the sleeve of the Drill chuck does not turn because of some troubles with the Drill chuck. Grip the periphery of the sleeve with the wrench, and turn the wrench counterclockwise.
  - The keyed Drill chuck of HP2070/HP2070F can be removed using a Wrench 43 (781024-2).

Reassembly;

When fastening the Drill chuck to the Spindle, set the torque of the Torque wrench shaft (1R223) to 35.7 to 45.9 N.m.

Fig. 3

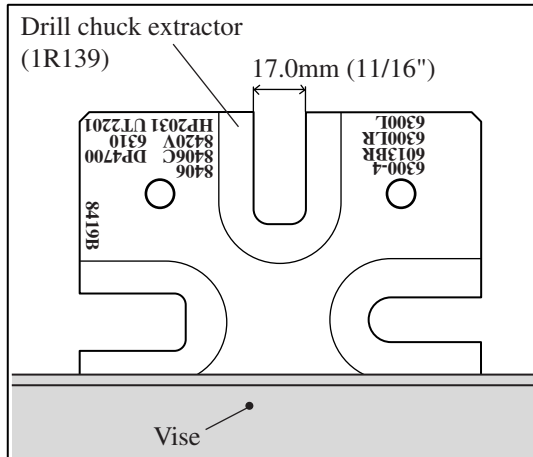
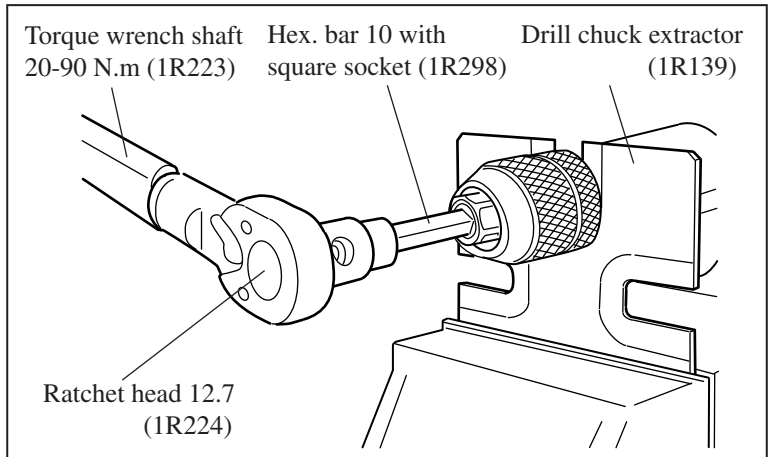


Fig. 4



2) Carbon Brush

Disassembly;

- 1) Remove the three 4x25 Tapping screws, and separate the Handle cover from the Motor housing. (Fig. 5)
- 2) Turn the Brush holder unit (= F/R switch) to reverse position, and then remove the Carbon brush positioned on the opposite side of the Trigger switch using a small slotted screwdriver. (Fig. 6)
- 3) Take the Trigger switch off from the Motor housing, and set the Brush holder unit in neutral position. And then remove the Carbon brush on the side of the Trigger switch. (Fig. 7)

**Note;** The Carbon brush on the side of the Trigger switch cannot be removed, if you turn the Brush holder unit in neutral position before separating the Switch trigger from the Motor housing.

Fig. 5

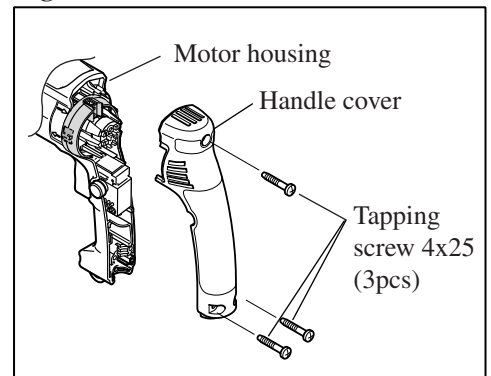


Fig. 6

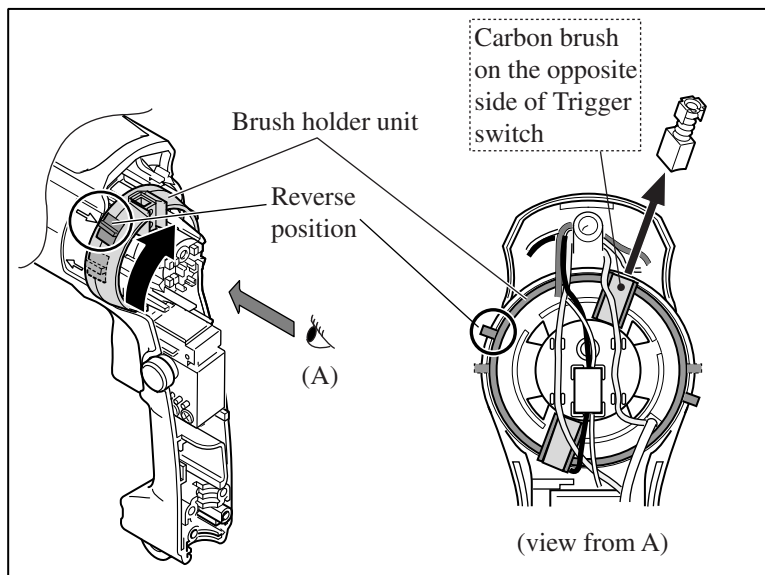
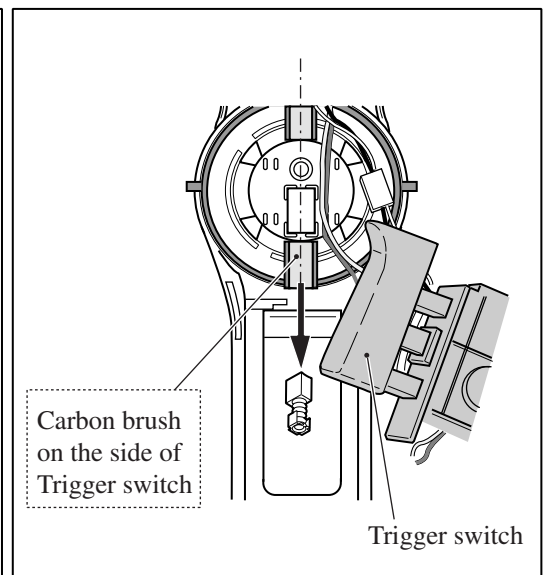


Fig. 7



<2> Disassembling and Reassembling Procedures

3) Armature assembly

Disassembly;

- 1) Remove the Carbon brushes as described on page 3. (Fig. 5, 6, 7)
- 2) Remove the three 4x35 Tapping screws, and then take out of the Motor housing the unit of the Armature assembly and the Gear housing cover. (Fig. 8)
- 3) Remove the Rubber Pin 4 to separate the Change lever A and Lever case from the Gear housing cover.
- 4) And then remove the Gear housing cover from the Armature assembly using a Gear extractor (1R045). (Fig. 9)
- 5) The Ball bearing 607LLB on the side of commutator can be removed using a Bearing extractor (1R269).

Fig. 8

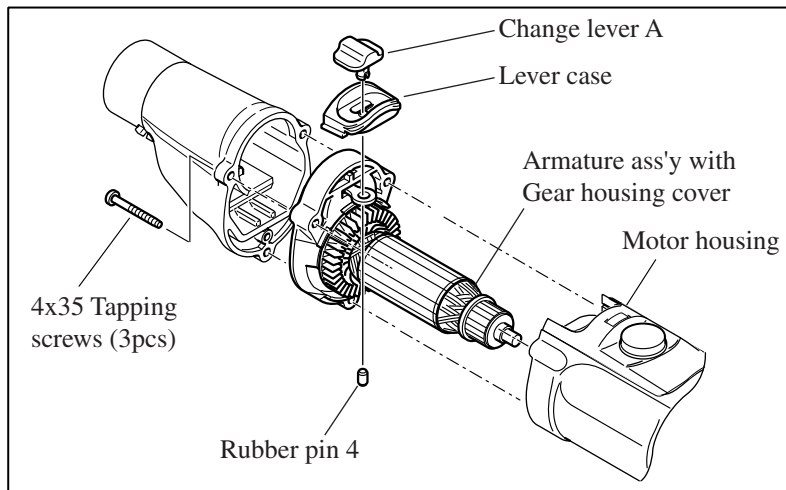
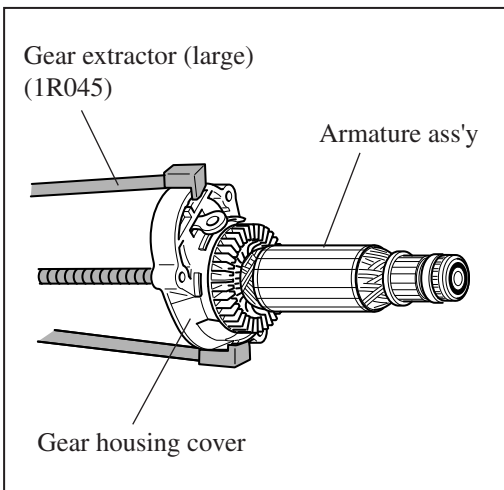


Fig. 9



4) Field and Brush holder unit

Disassembly;

- 1) Shift the Controller till the Connectors appears entirely out of the Motor housing, and disconnect the Connectors that connect the Controller with the Field. (Fig. 10)
- 2) In order to remove the Field, remove the two 4x70 Tapping screws, and then gently hit the Motor housing with plastic or wooden hammer. (Fig. 11)

Fig. 10

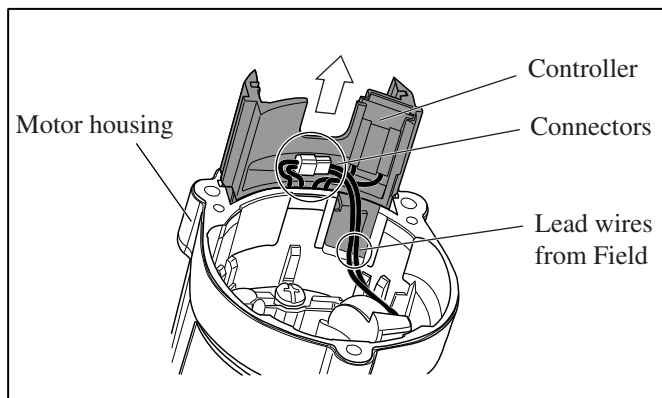
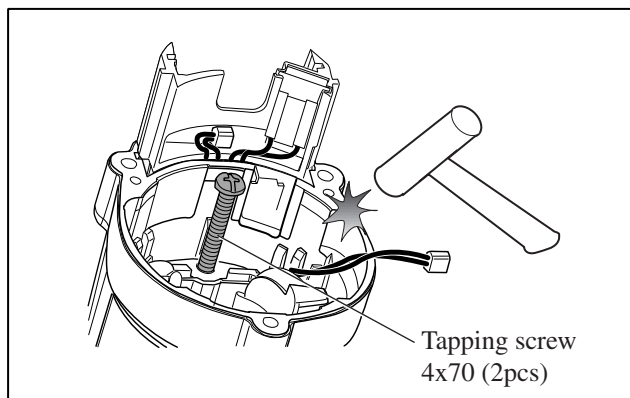
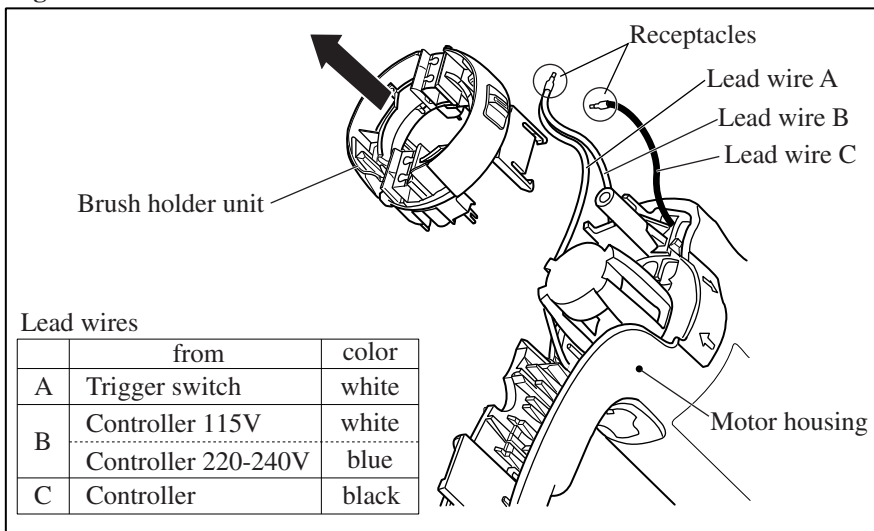


Fig. 11



- 3) The Brush holder unit can be removed from the Motor housing by pulling it in the direction of the black arrow after disconnecting the Lead wires which are connected to the Brush holder unit with the two Receptacles. (Fig. 12)

Fig. 12



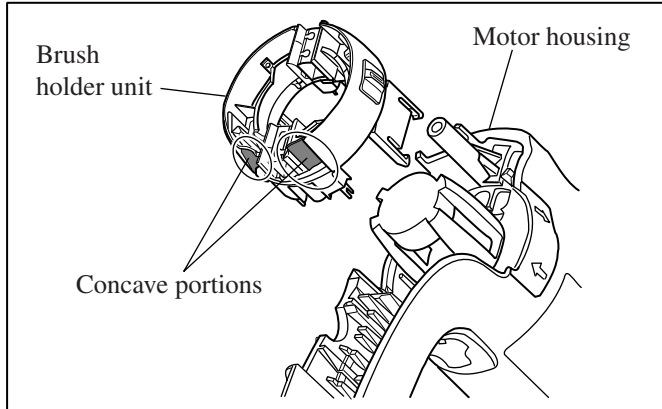
**Reassembly;**

- 1) When replacing the Field, be sure to remove the Brush holder unit from the Motor housing before installing a new Field. And install the Brush holder unit after installation of a new Field.

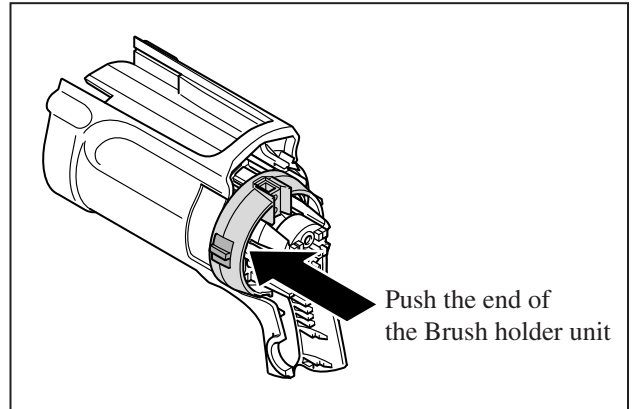
**Note:** When installing the Brush holder unit on the Motor housing, set the unit so that its two concave portions face the direction of the Trigger switch. (**Fig. 13**)

- 2) When fastening the 4x70 Tapping screws (Field screws), be sure to press the end of the Brush holder unit so that the unit cannot be pushed out of position. (**Fig. 14**)

**Fig. 13**



**Fig. 14**

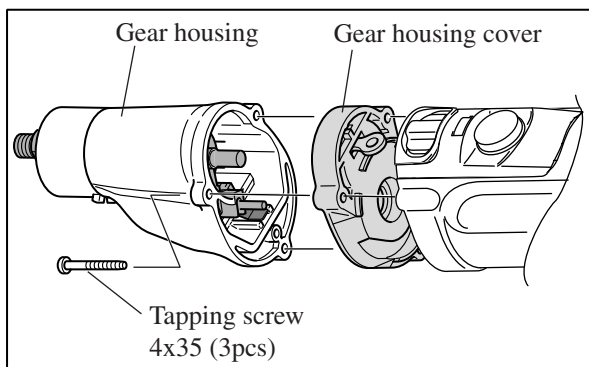


**5) Gear section**

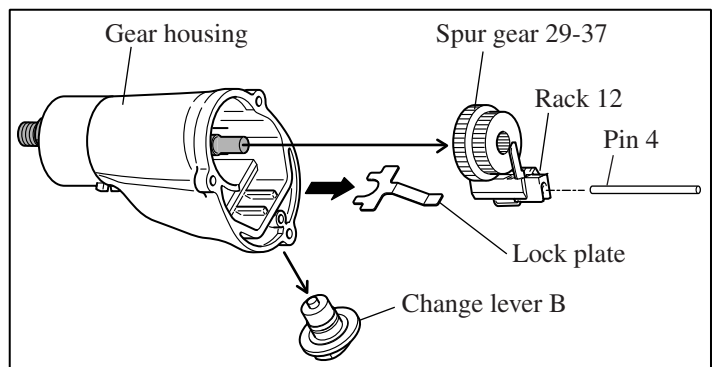
**Disassembly;**

- 1) Remove the three 4x35 Tapping screws, and then separate the Gear housing from the Gear housing cover. (**Fig. 15**)
- 2) By pulling the Lock plate from the Gear housing, the following parts can be removed from the Gear housing; Change lever B, Pin 4, Rack 12, Spur gear 29-37 (**Fig. 16**)

**Fig. 15**



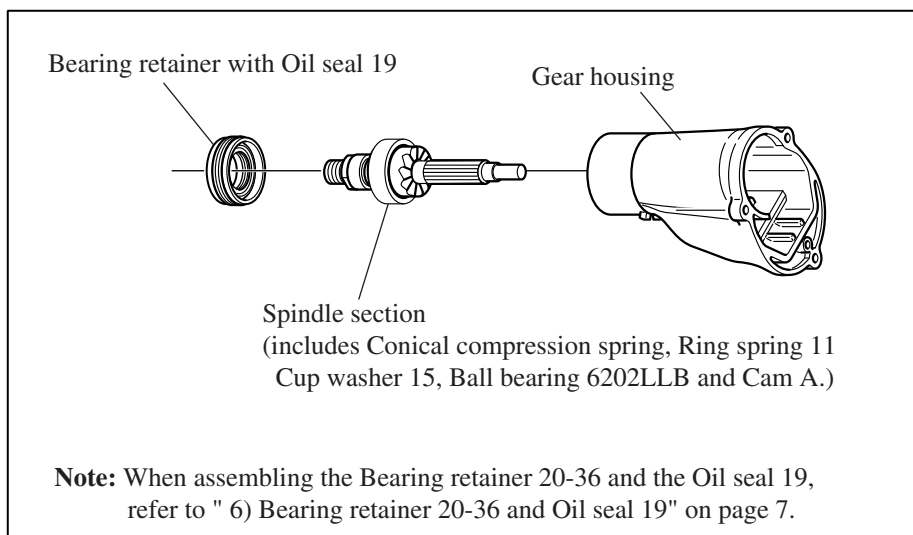
**Fig. 16**



**Reassembly;**

- 1) Assemble the Spindle section to the Gear housing as illustrated in **Fig. 17**.

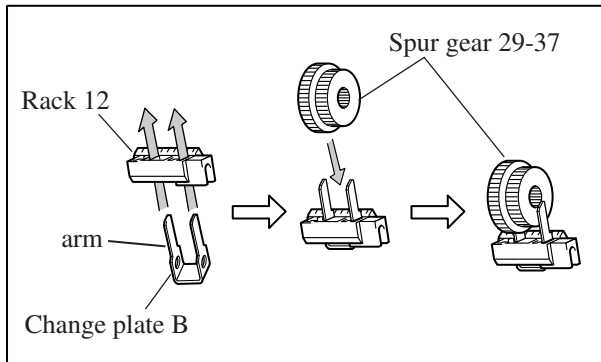
**Fig. 17**



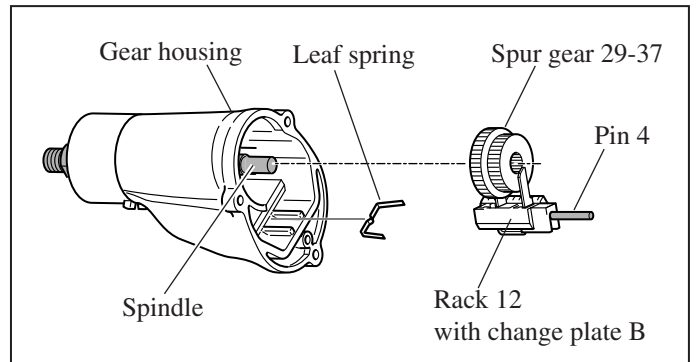
("Reassembly of Gear section" continues to page 6.)

- 2) Insert the arms of the Change plate B through the slots in the Rack 12, and then put the Spur gear 29-37 between the arms of the Change plate B. **(Fig. 18)**
- 3) Insert the Pin 4 into the Rack 12. Place the Gear housing as illustrated below, and then install the Gear 29-37 on the Spindle together with the parts you have assembled to the Gear 29-37. **(Fig. 19)**  
At this time, do not fail to set the Leaf spring in place in the Gear housing. **(Fig. 19)**

**Fig. 18**

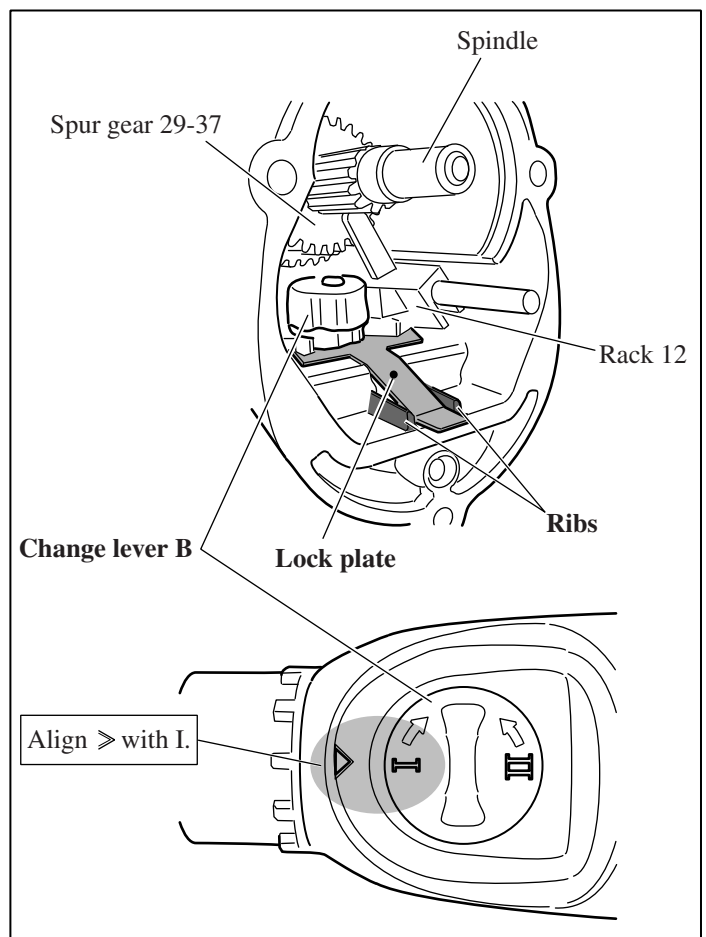


**Fig. 19**



- 4) Push the Rack 12 into the Gear housing till it stops.  
And then, install the Change lever B on the Gear housing with its "I" mark which indicates low speed aligned with the triangular mark on the Gear housing. **(Fig. 20)**
- 5) Install the Lock plate on the Gear housing with its tail portion inserted between the ribs on the Gear housing as illustrated in **Fig. 20**.

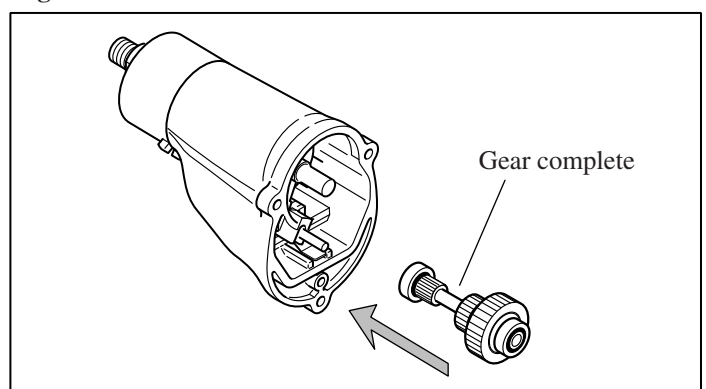
**Fig. 20**



- 6) Assemble the Gear complete to the Gear housing as illustrated in **Fig. 21**.

**Note:** Do not disassemble the Gear complete, because it has torque limiter function and requires very difficult adjustment when reassembled.

**Fig. 21**

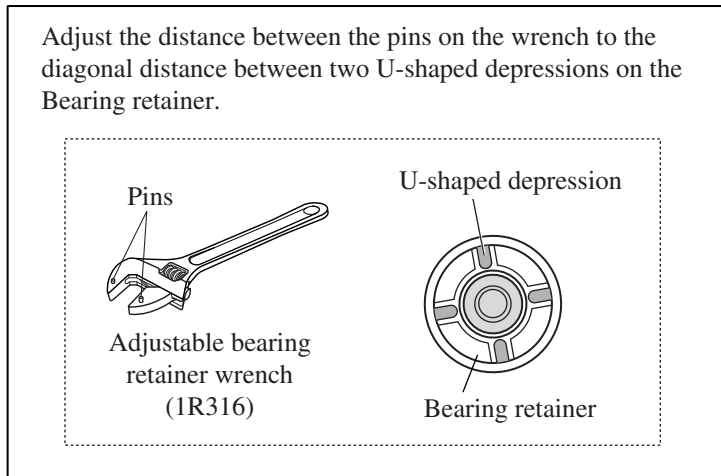


**6) Bearing Retainer 20-36 and Oil Seal 19**

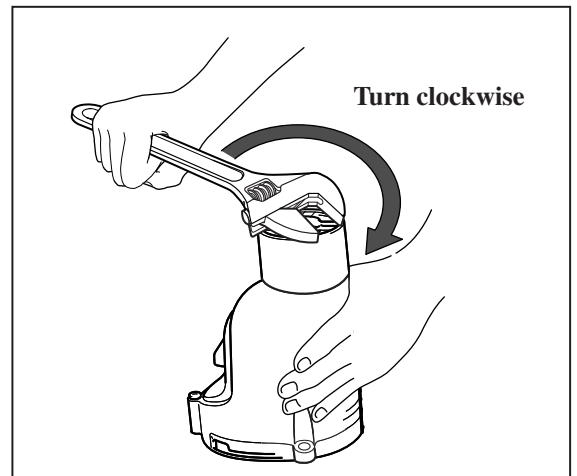
**Disassembly;**

- 1) Using an Adjustable bearing retainer wrench (1R316), remove the Bearing retainer from the Gear housing. **(Fig. 22)**  
As the Bearing retainer has left-hand threads, turn the Bearing retainer 20-36 clockwise for loosening. **(Fig. 23)**
- 2) And then remove the Oil seal 19 from the Bearing retainer by deforming the seal with small slotted screwdriver.

**Fig. 22**



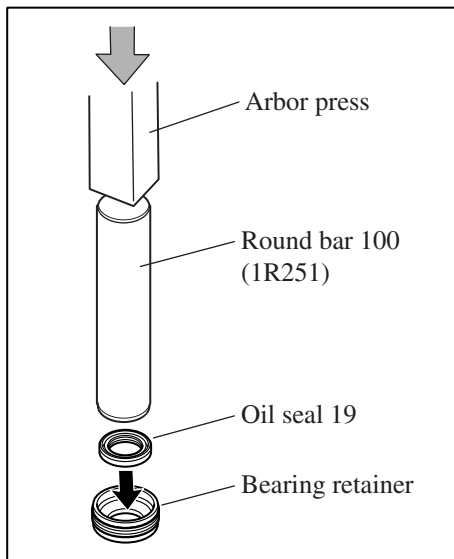
**Fig. 23**



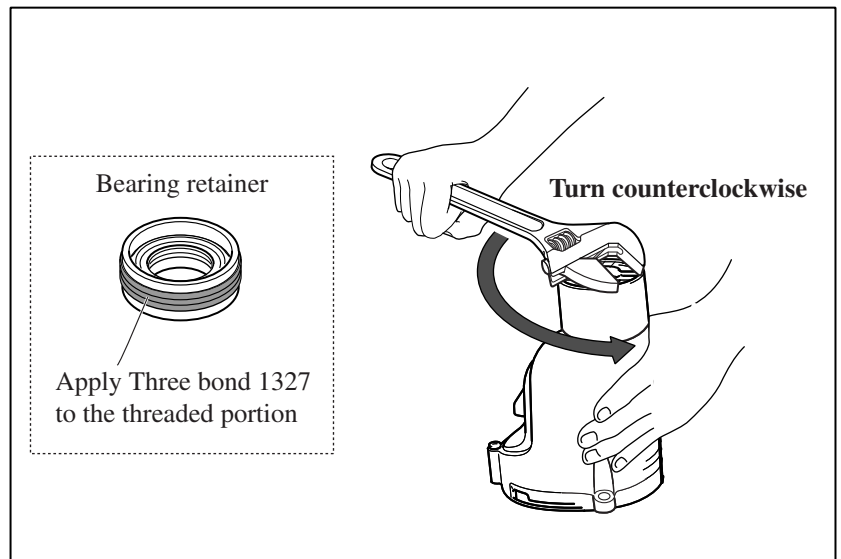
**Reassembly;**

- 1) Press-fit the Oil seal 19 into the Bearing retainer using an arbor press and a Round bar 100 (1R251). **(Fig. 24)**  
**Note:** When installing a fresh Oil seal 19, apply proper amount of Makita grease N No.1 to its periphery beforehand.
- 2) Put appropriate amount of Three bond 1327 to the threaded portion of the Bearing retainer.  
And then fasten the Bearing retainer securely to the Gear housing by turning it counterclockwise with an Adjustable bearing retainer wrench (1R316). **(Fig. 25)**

**Fig. 24**



**Fig. 25**

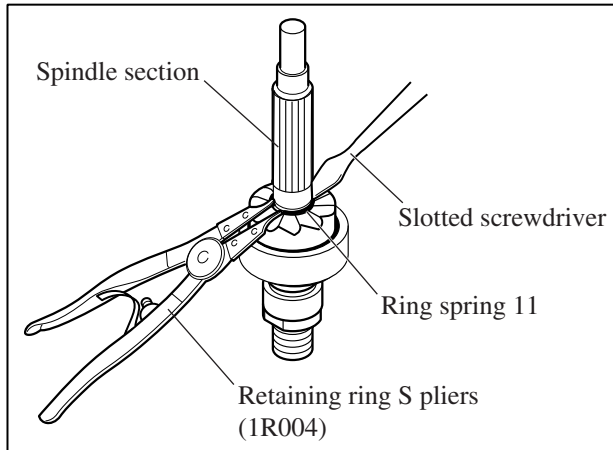


**6) Spindle section**

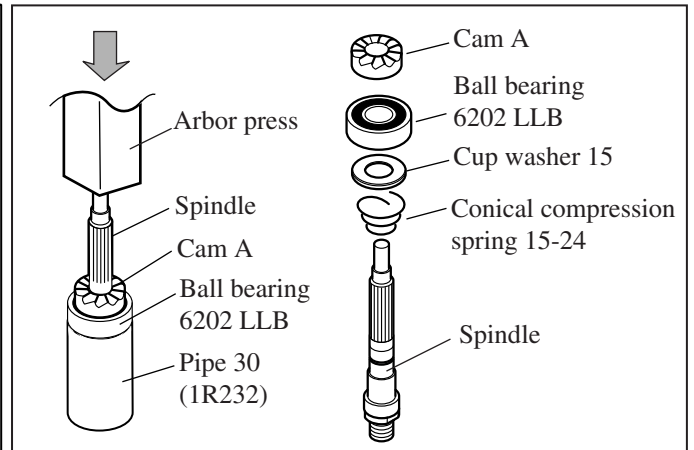
**Disassembly;**

- 1) Remove the Ring spring 11 from the Spindle section using a Retaining ring S pliers. (**Fig. 25**)
- 2) Hold the Ball bearing 6202LLB on the Pipe 30 (1R232), and then, by pressing the Spindle with arbor press, the following parts can be removed from the Spindle;  
Cam A, Ball bearing 6202LLB, Cup washer 15, Conical compression spring (Fig. 26)

**Fig. 25**



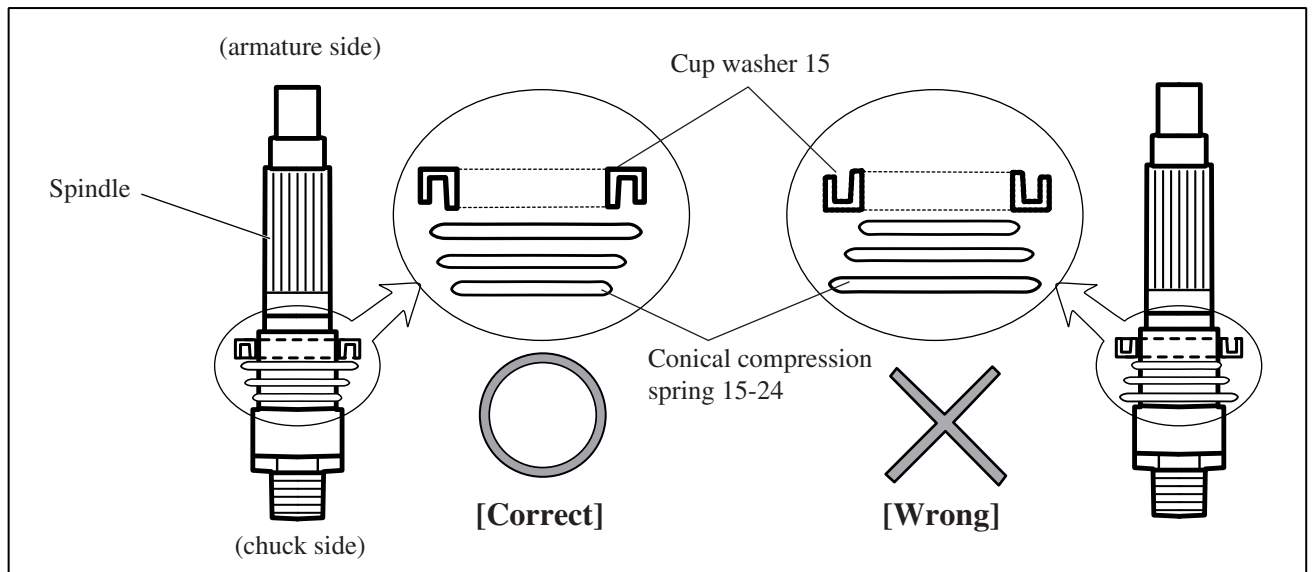
**Fig. 26**



**Reassembly;**

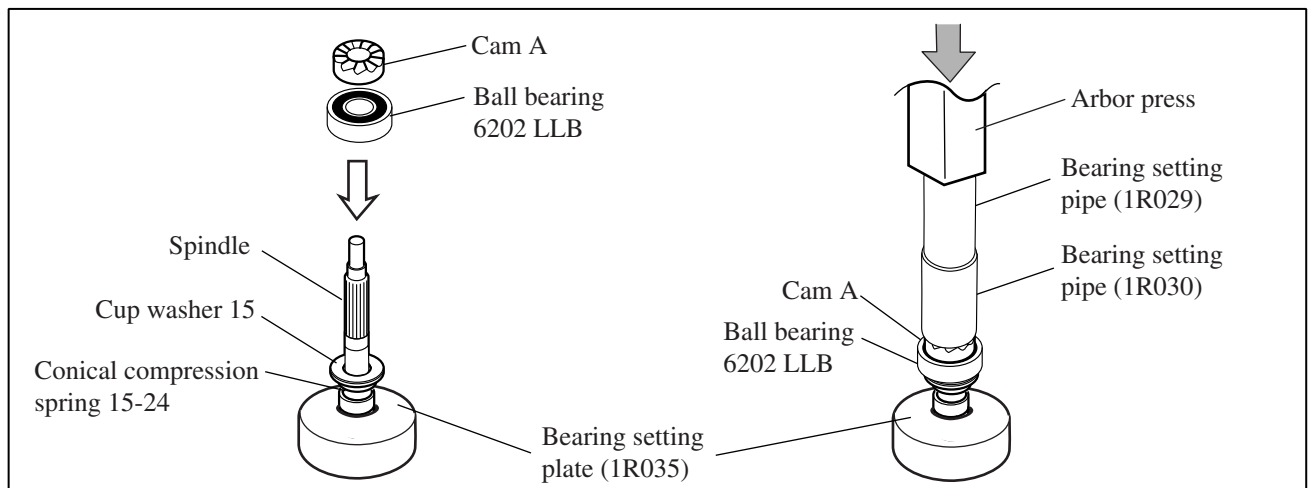
- 1) Install the Conical compression spring 15-24 and the Cup washer on the Spindle as illustrated in Fig. 27.

**Fig. 27**



- 2) Press-fit the Cam A and the Ball bearing 6202LLB onto the Spindle using the following repairing tools;  
Arbor press, Bearing setting pipe 15.2-23 (1R029), Bearing setting pipe 17.2-25(1R030),  
Bearing setting plate (1R035) (**Fig. 28**)





**Fig. 28**

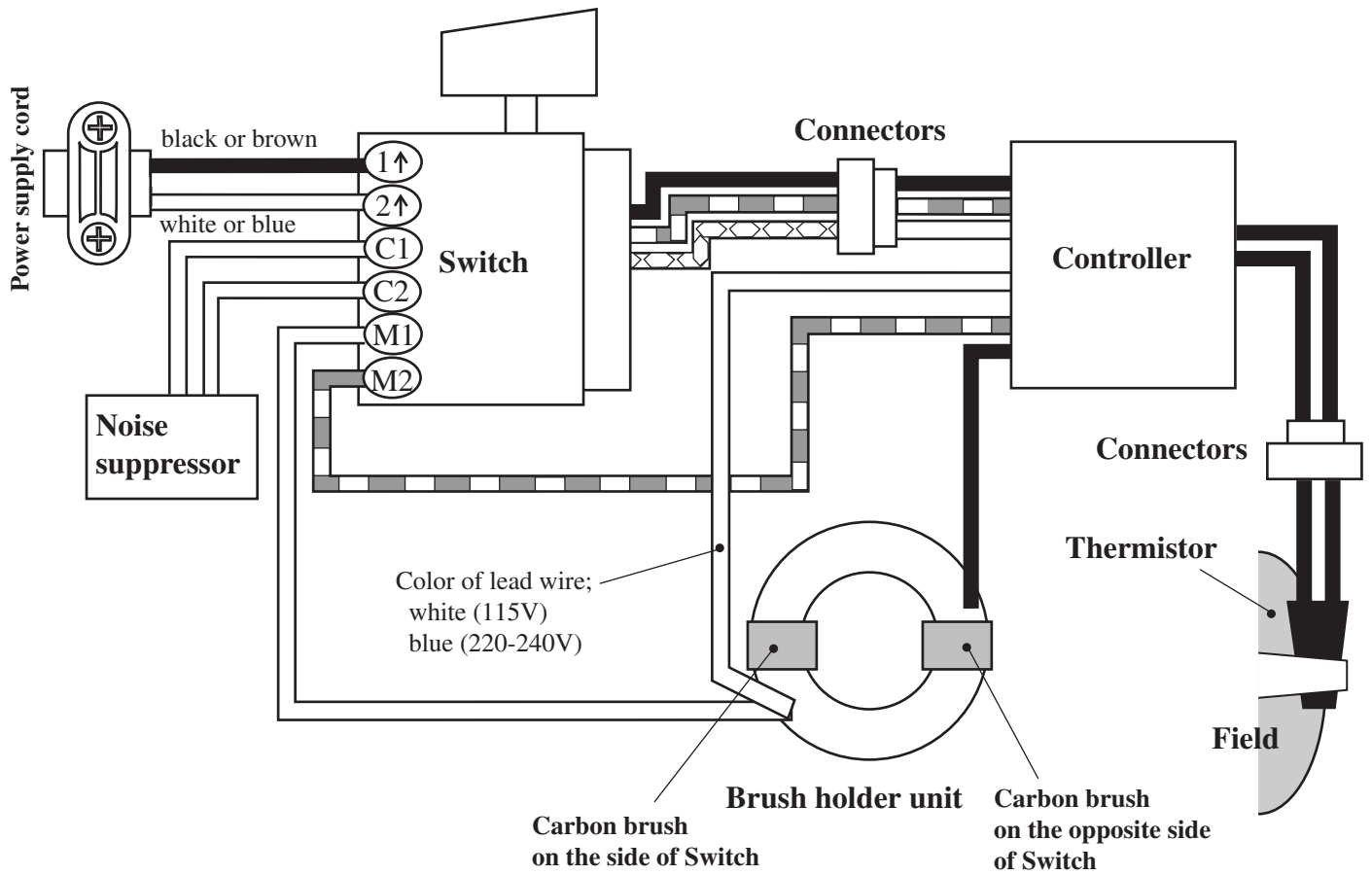




► **Circuit diagram**

**1) HP2070 & HP2071 (without LED job light)**





Color index of lead wires	
Black	
White	
Red	
Yellow	

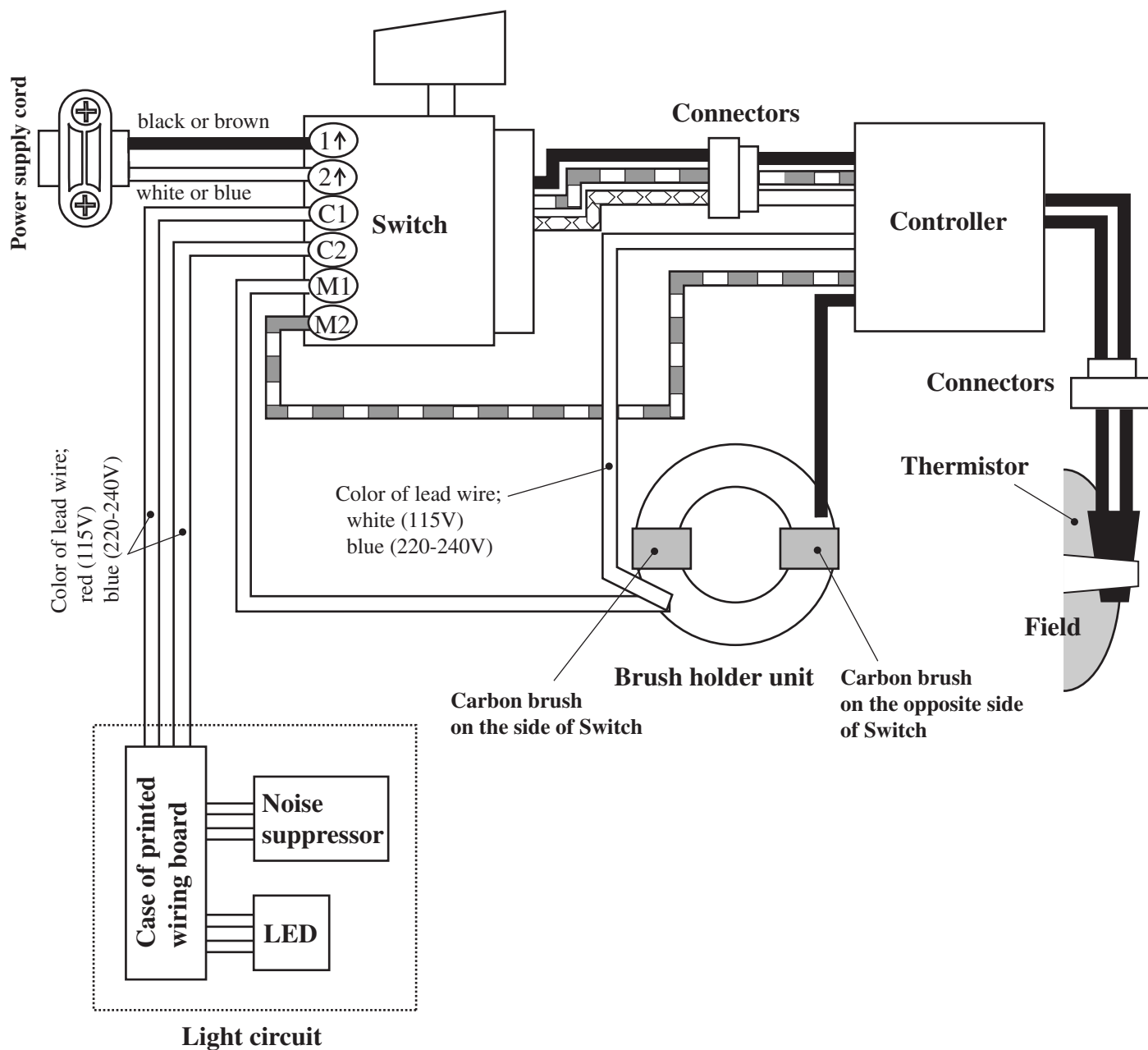


**Note:** Noise suppressor is not used for some countries.

► **Circuit diagram**

**2) HP2070F & HP2071F (with LED job light)**

Color index of lead wires	
Black	
White	
Red	
Yellow	



**Note:** Noise suppressor is not used for some countries.

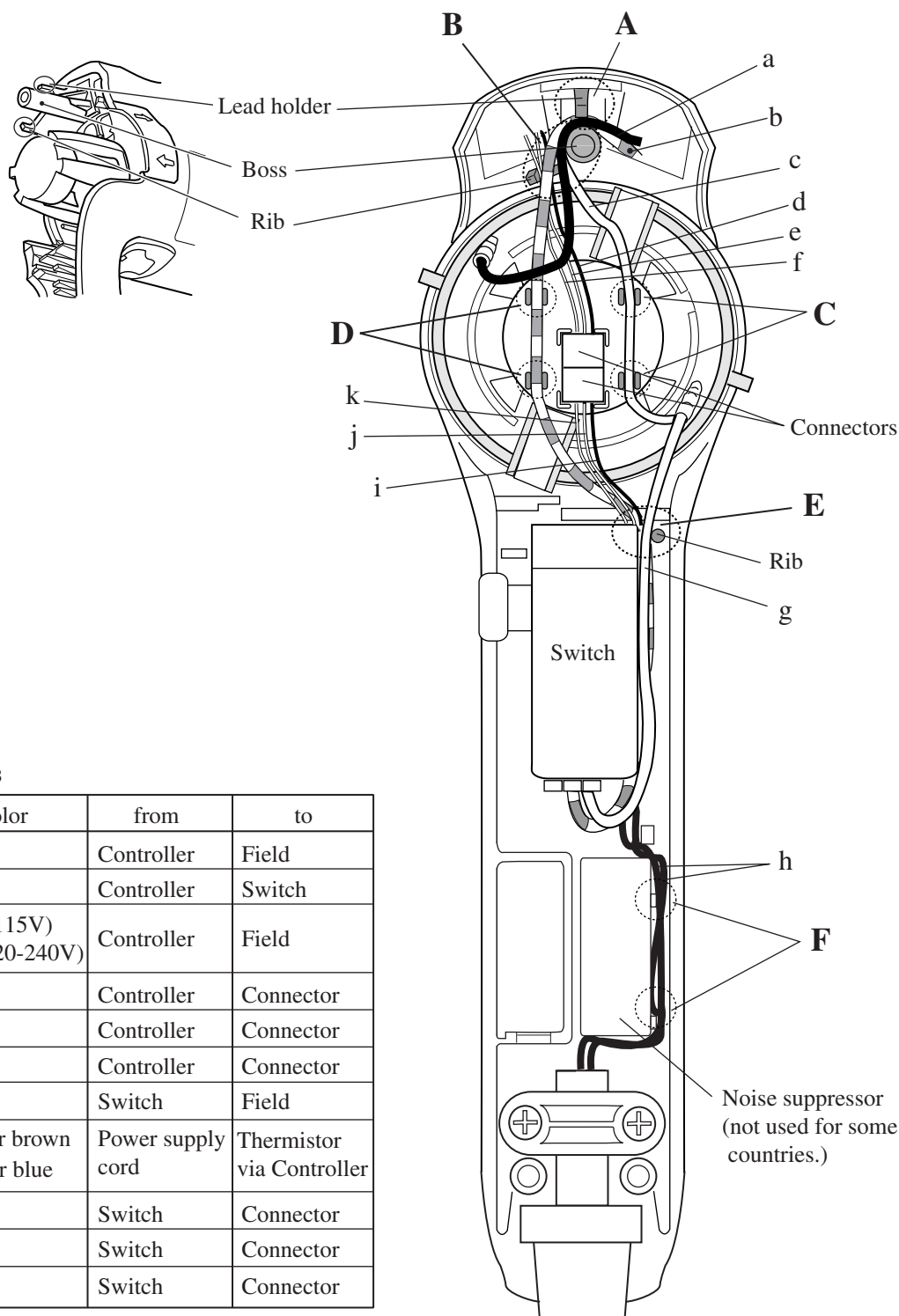
## ► Wiring diagram (1)

### 1) HP2070 & HP2071 (without LED job light)

Route lead wires as illustrated in Fig. 28.

Fig. 28

- A) Fix the two lead wires (a, b) from the Controller at the lead holder.  
 B) Route the lead wires (a, b, c, d, e, f) from the Controller between the rib and the boss.  
 C) Fix the white lead wire (c) from the Controller at the lead holders.  
 D) Fix the red lead wire (b) from the Controller at the lead holders.  
 E) Route the lead wires (b, g, i, j, k) between the rib and the Switch.  
 F) Route the lead wires (h) from the Power supply cord between the ribs and the wall of the Motor housing.



Lead wires

	color	from	to
a	black	Controller	Field
b	red	Controller	Switch
c	white (115V) blue (220-240V)	Controller	Field
d	black	Controller	Connector
e	red	Controller	Connector
f	white	Controller	Connector
g	white	Switch	Field
h	black or brown white or blue	Power supply cord	Thermistor via Controller
i	black	Switch	Connector
j	red	Switch	Connector
k	yellow	Switch	Connector

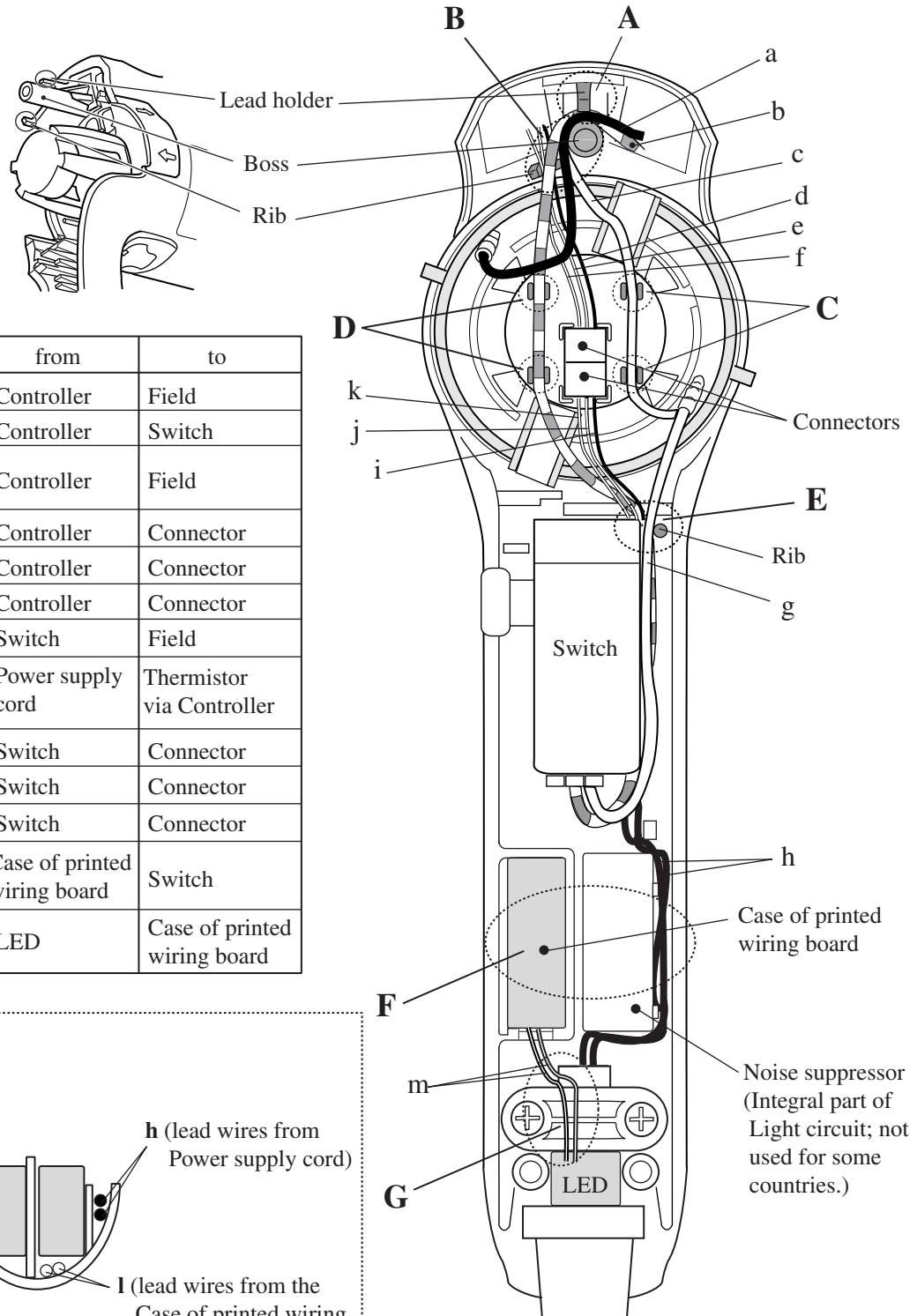
► **Wiring diagram (1)**

**2) HP2070F & HP2071F (with LED job light)**

Route lead wires as illustrated in **Fig. 29**.

**Fig. 29**

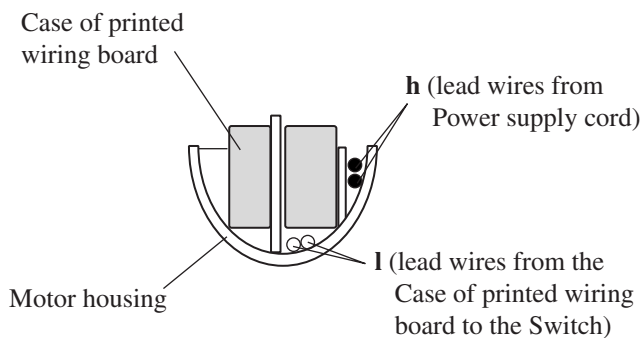
- A) Fix the two lead wires (a, b) from the Controller at the lead holder.
- B) Route the lead wires (a, b, c, d, e, f) from the Controller between the rib and the boss.
- C) Fix the white lead wire (c) from the Controller at the lead holders.
- D) Fix the red lead wire (b) from the Controller at the lead holders.
- E) Route the lead wires (b, g, i, j, k) between the rib and the Switch.
- F) Route the lead wires (h, l) as illustrated below in "cross section of F".
- G) Route the lead wires as illustrated below.



**Lead wires**

	color	from	to
a	black	Controller	Field
b	red	Controller	Switch
c	white (115V) blue (220-240V)	Controller	Field
d	black	Controller	Connector
e	red	Controller	Connector
f	white	Controller	Connector
g	white	Switch	Field
h	black or brown white or blue	Power supply cord	Thermistor via Controller
i	black	Switch	Connector
j	red	Switch	Connector
k	yellow	Switch	Connector
l	red (115V) blue (220-240V)	Case of printed wiring board	Switch
m	white	LED	Case of printed wiring board

[Cross section of F]

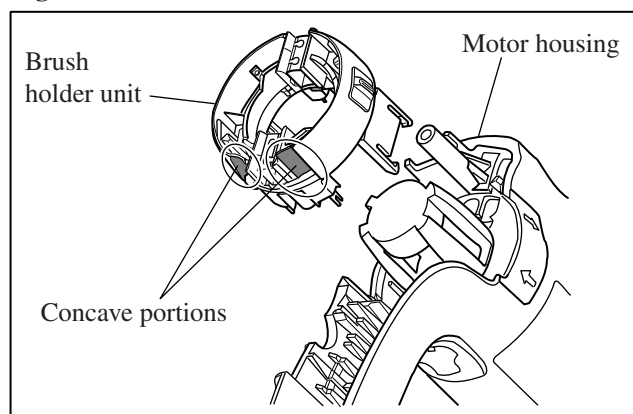


## ► Wiring diagram (2)

### For all models

- When installing the Brush holder unit on the Motor housing, set the unit so that its two concave portions face the direction of the Trigger switch. (**Fig. 30**)

**Fig. 30**

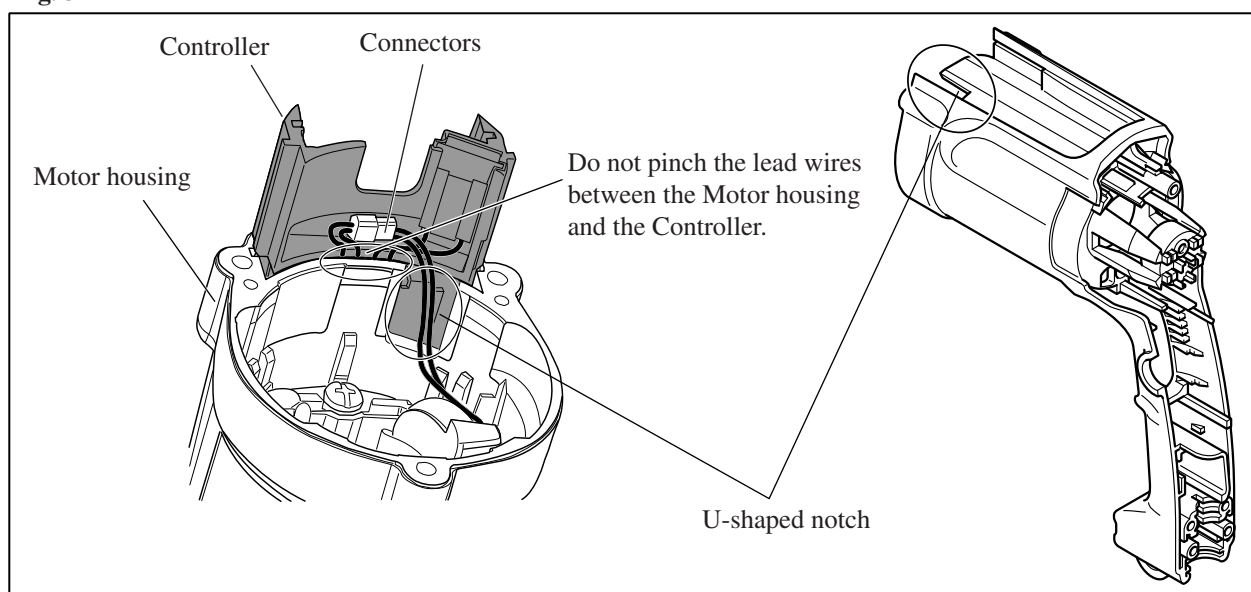


- Place the Connectors as illustrated in **Fig. 31**. Do not place it on the side of the U-shaped notch in the Motor housing.

#### Note:

Be careful not to pinch the lead wires between the Motor housing and the Controller.

**Fig. 31**



## ► Keyless drill chuck 13

### HP2071 & HP2071F

If the Keyless drill chuck 13 cannot be loosened because of a jammed drill bit, take the following procedures to loosen the chuck;

- 1) Fix the sleeve section of the chuck securely with an adjustable spanner, etc. (**Fig. 31**)

**Note:** Don not fix the retaining section at this time.

- 2) And then, with a wrench 19, etc, turn the hex. nut on the top of the chuck clockwise to loosen the chuck. (**Fig. 31**)

**Fig. 31**

