

**For Models** ▶ HM 1800

**Description** ▶ Hammer drill

## CONCEPTION AND MAIN APPLICATIONS

We developed the Hammer drill aiming at double insulation of 8600N anti-shake-proof of side handle as well as attaching of air tools.

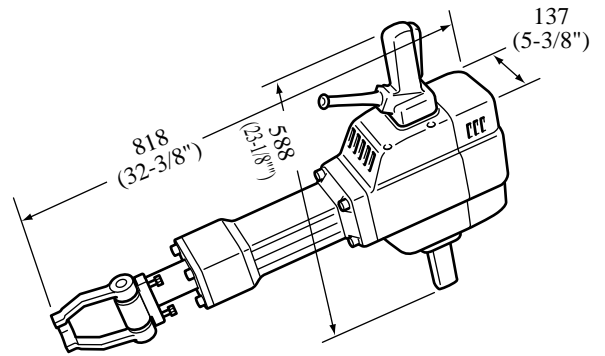

### ► Specifications

Voltage (V)	Current(A)	Frequency (Hz)	Consuming power(W)	Nominal output(W)	Max. output(W)
100	15.0	50/60	1,430	820	1,650
115	15.0	50/60	1,650	750	1,400
200	7.5	50/60	1,430	820	1,650
220	8.2	50/60	1,700	1,050	2,300
230	7.8	50/60	1,700	1,050	2,300
240	7.5	50/60	1,700	1,050	2,300

<b>Motor</b>	Single phase series wound commutator motor
<b>Speed at no load</b>	1,000 P/min
<b>Attaching tool size</b>	286 mm ( Specified export : 31.8 mm)
<b>For hitting only</b>	( Chipping by Bull point, Scaling chisel, Cold chisel; Earth digging by scop, Ramming by rammer, etc.)

### ► Standard equipment

Hex. Wrench 5,6,10  
Wooden box

### ► Optional accessories

Bull point,  
Scaling chisel  
Cold chisel  
Scoop  
Rammer

## ► Repair

### 1. In exchanging only Armature

- 1) Take away four bolts (Hex. Socket head bolt M6x20) fixing Motor housing.
- 2) Remove Holder cap and Carbon brush.
- 3) Hex. Nut M12 attaching Handle base in Handle side.
- 4) Remove four bolts (Hex. Socket head bolt M12x55) fixing Cylinder A , separate Cylinder A from Clunk housing , and detach Connecting rod and Piston cylinder attachment from Clunk shaft.
- 5) Take away four bolts ( Hex. Socket head bolt M8x75) fixing Gear housing, separate Gear housing cover from Gear housing. At that time leave Helical gear 50 in Gear housing.
- 6) Insert + Driver into a hole in the side of Helical gear 50 and fix Helical gear to set up Armature rotation. Remove Hex. Nut M8-13 fixing Fan 100 by Box wrench.

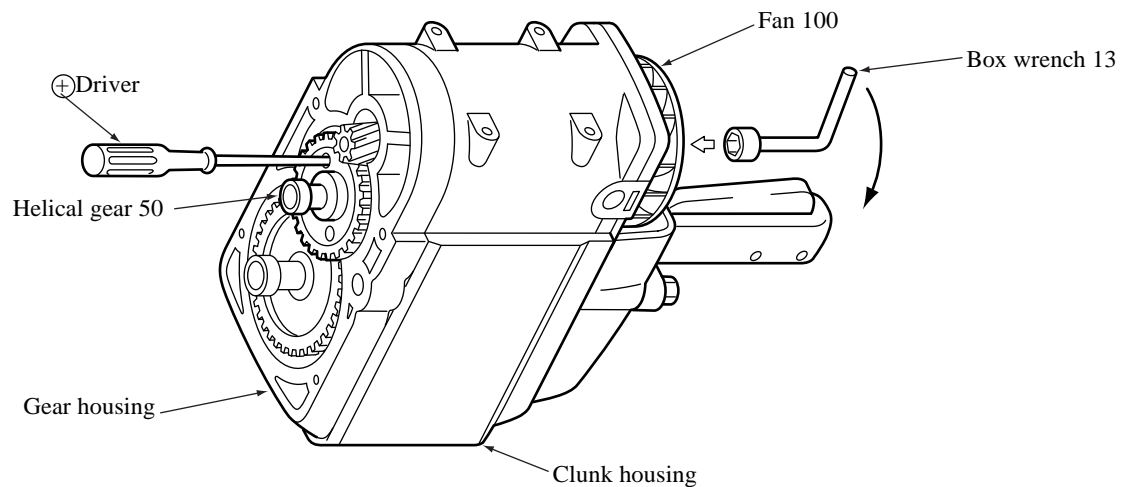

7) Detach Gear housing from Clunk housing. Then Fan 100 comes off from Armature.

8) Pull out Armature form Gear housing.

- The above disassembly procedure is how to exchange Armature without detaching wiring.
- You can assemble them in a reverse order.

2. In exchanging both Field and Armature

I Disassembly

- 1) Above procedure 1)
- 2) Above procedure 2)
- 3) Remove Field lead wire terminal in Handle from Switch.
- 4) Remove Hex. Nut M12 fixing Handle base in Switch side.
- 5) Remove three bolts(Hex. Socket head M6x35) fixing Rear case, and detach Rear case from Clunk housing.
- 6) Remove four screws (+Pan head machine screw M5x18) fixing Cap cover , and separate Cap cover from Clunk housing cap. Cut off Insulated connector in Clunk housing cap. See the illustration below.

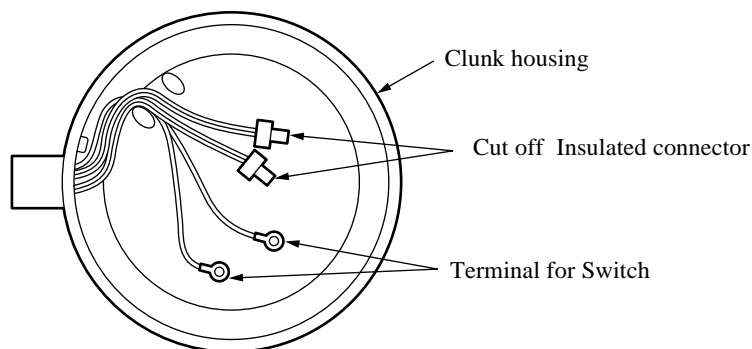

Pulling out Lead wire, detach Clunk housing cap from Motor housing B.

- 7) Pull out four bolts (Hex. Socket head bolt M6x 25) fixing Motor housing B together with Armature, Fan 100 and Motor housing B. See the illustrationbelow.

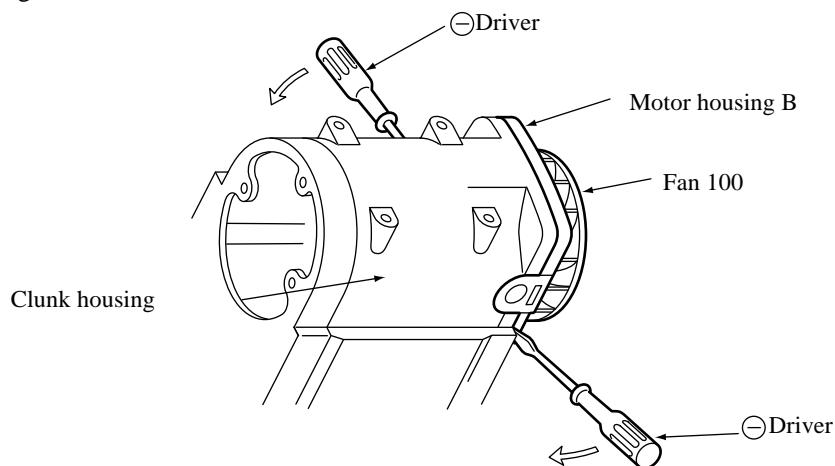

Hold lightly Outer circle of Armature steel plate by Vice, remove Hex.nutM8-13 fixing Fan 100 by Box wrench, and separate Fan 100, Motor housing B and Armature respectively.

8) If you hit the end face of Clunk housing strongly by Plastic hammer, a unit of Motor housing A and Field come off.

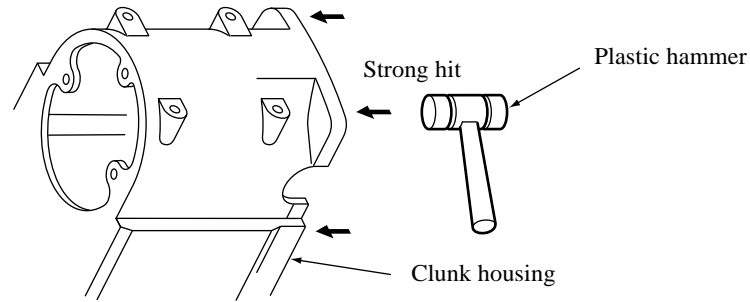

9) Remove two bolts (+Hex. Bolt M5x85) fixing Field, and pat the end face of Housing A by Plastic hammer, then Field comes out.

## II Assembly

1) Insert Motor housing A in Clunk housing. At that time make the projection of Motor housing A meet Clunk housing hole. See the illustration below.

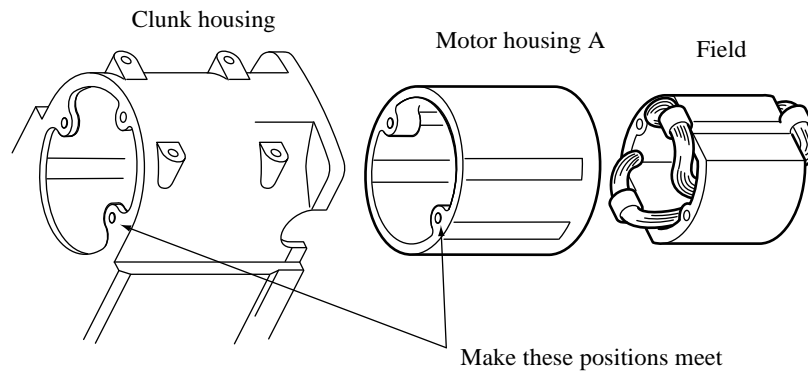

2) Insert Field into Motor housing A.

3) Insert Armature in Motor housing B, hold Outer circle of Armature steel plate by Vice, and fix Fan 100 by tightening Hex. Nut M8-13 with Box wrench.

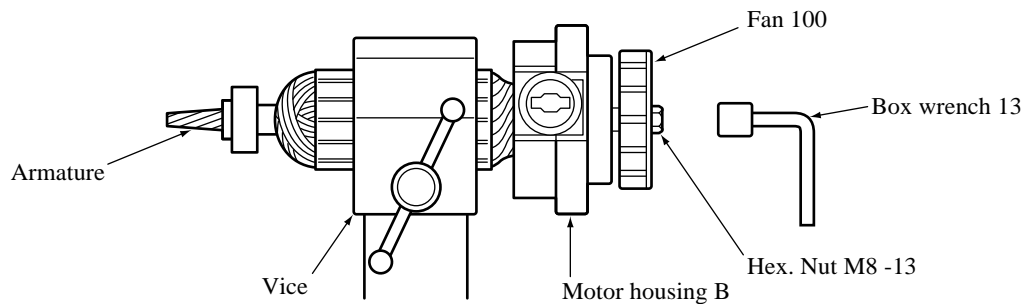

4) Make four Field lead wires pass through the hole for Lead wire of Motor housing B.

5) Pulling the above four wires, insert Motor housing B, Armature, and Fan 100 attachment into Clunk housing. ( If Lead wire loosens then, it may contact with Armature. Be careful.)

3. Where to grease

In assembly, apply Grease (Makita grease R No.00) to O ring, X ring, Oil seal, the inside of Piston cylinder, and Rib of Cylinder A.

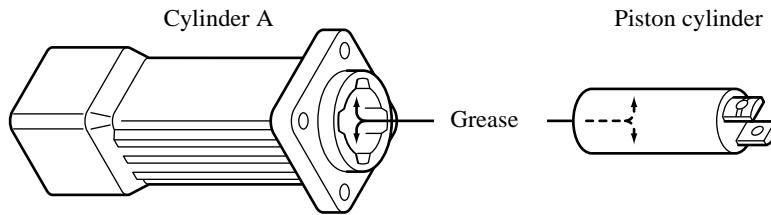

4. Attaching direction of Tool retainer shaft

In the following direction of Tool retainer, direct the notch of Tool retainer shaft toward the Arrow mark, and insert it from the end face with taper treatment.

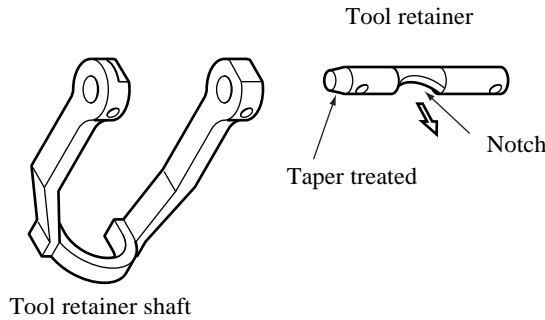

5. Fixing of Retainer ring

Insert 12 round rod into a hole for Tool holder fixing, and insert Pin 4, pressing Compression spring 13.

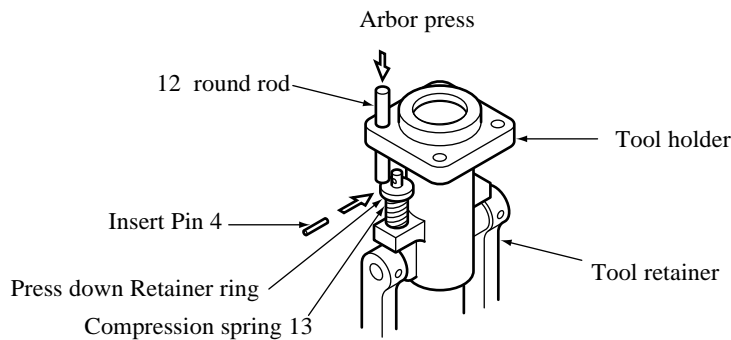

6. Direction of Tool retainer

1) In case of Tool holder 29 ( for 1-1/8" Bit ), install so that Tool retainer and Handle shaft may be positioned as the following illustration.

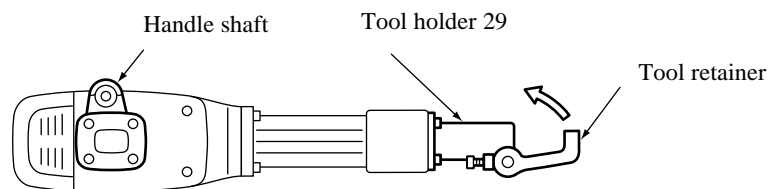

2) In case of Tool holder 32 ( for special export, 1-1/4" Bit )

Install so that the positions of Tool retainer and Switch are as the above illustration.

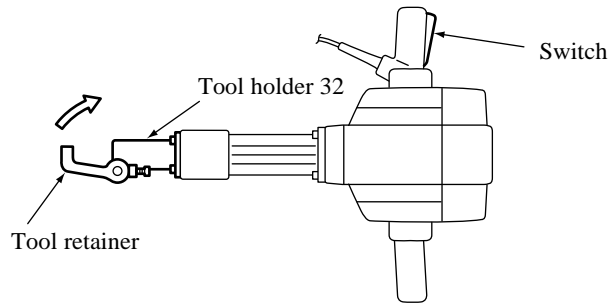

7. Attaching direction of Countersunk spring washer as for the attaching direction of Countersunk spring washer to be used for Tool holder fixing bolt, refer to the right illustration.

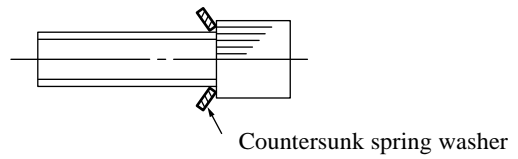

8. Installation of Impact bolt holder

Press Impact bolt holder into Cylinder B by Arbor press. See the right illustration.

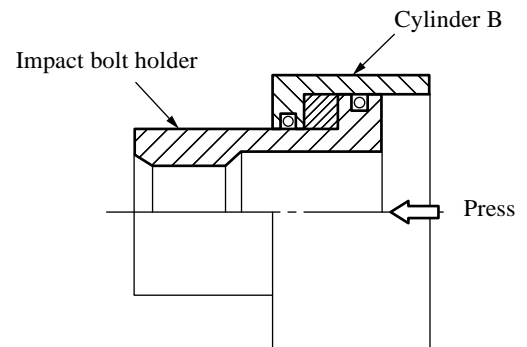

9. Application of adhesive

Apply the adhesive (Three Bond 1215 ) to the in-low parts of Gear housing and Gear housing cover.

See the illustration below.

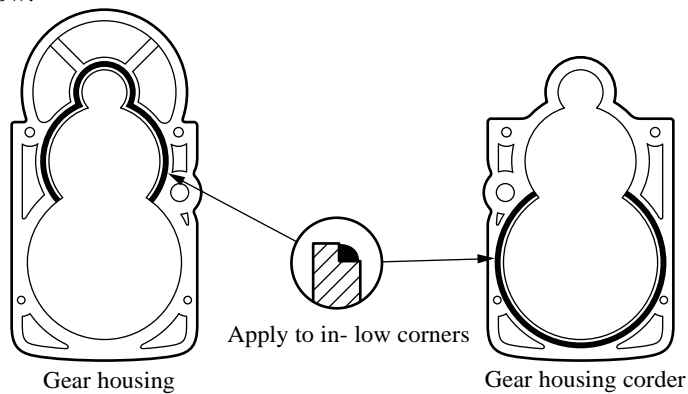

## 10. Tightening torque of Bolts/Nuts

Hex. Socket head bolt	M12x45 (for fixing Tool holder)	650~850kgf•cm	47.0~61.5(ft•lbs)
"	M12x55(for fixing Cylinder A)	650~850kgf•cm	47.0~61.5(ft•lbs)
"	M8x75(for fixing Gear housing cover)	250~400kgf•cm	18.0~28.9(ft•lbs)
"	M6x20(for fixing Motor housing cover )	60~80kgf•cm	4.3~5.8(ft•lbs)
"	M6x25 ( for fixing Motor housing B for fixing Handle R/L for fixing Side handle )	60~80kgf•cm	4.3~5.8(ft•lbs)
"	M6x35 (for fixing Rear case)	130~160kgf•cm	9.4~11.6(ft•lbs)
Hex. Nut M8-13	(for fixing Fan)	60~80kgf•cm	4.3~5.8(ft•lbs)
"	M12 (for fixing Handle base)	250~400kgf•cm	18.0~28.9(ft•lbs)

## 11. Exchange of Grease

Remove Hex.socket head bolt M12x55 for fixing Cylinder A, detach Cylinder A from Clunk housing. Wipe away grease sticking to Walls by cloth, and put new Makita grease R No.00, 80~100g (0.18~0.22lbs), into Cylinder A and Clunk housing.

### ► Diagram

