

T ECHNICAL INFORMATION

Models No. ▶ HM1242C

Description ▶ Demolition Hammer

112mm(4-3/8")

P 1/ 12

CONCEPTION AND MAIN APPLICATIONS

HM1242C is the 10 Kg class hammer for BOSCH shank type hammer bits (3/4" Hex 21/32 Round shank)

This model is taking over the existing HM1202C's benefits in incredibly low noise, compact body and the strongest demolishing power in this class.

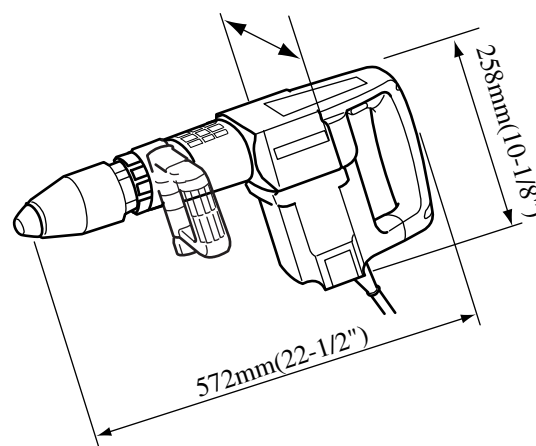

► Specification

| Voltage (V) | Current (A) | Cycle (Hz) | Continuous Rating (W) | | Max. Output(W) |
|-------------|-------------|------------|-----------------------|--------|----------------|
| | | | Input | Output | |
| 100 | 15 | 50 / 60 | 1,450 | 500 | 1,600 |
| 115 | 15 | 50 / 60 | 1,450 | 500 | 1,600 |
| 120 | 13 | 50 / 60 | 1,450 | 500 | 1,600 |
| 220 | 7.3 | 50 / 60 | 1,450 | 550 | 1,800 |
| 230 | 7.0 | 50 / 60 | 1,450 | 550 | 1,800 |
| 240 | 6.7 | 50 / 60 | 1,450 | 550 | 1,800 |

| | |
|-------------------------|------------------------------|
| Bit-type | BOSCH shank type hammer bits |
| Blows per minute | 950-1,900 (bpm) |
| Net Weight | 9.3kg (20.5 lbs) |
| Size of shank | (3/4" Hex 21/32 Round shank) |
| Cord Length | 5m (16.4 ft) |

► Standard equipment

Grease for bit 1 pc.

< Note > The standard equipment for the tool shown may be differ from country to country.

► Optional accessories

Bull point 19-300

Bull point 19-450

Cold chisel 26-300

Cold chisel 26-450

Scaling chisel 50-300

Grooving chisel 22-300

Grooving chisel 26-300

Clay spade 105-400

Rammer 140

Bushing tool 67-300

► Repair

<1> Removing armature

- (1) Take off the rear cover from the motor housing by loosening 2 pcs. of tapping screw M4x18. And then take off the carbon brushes after taking off the brush holder cap.

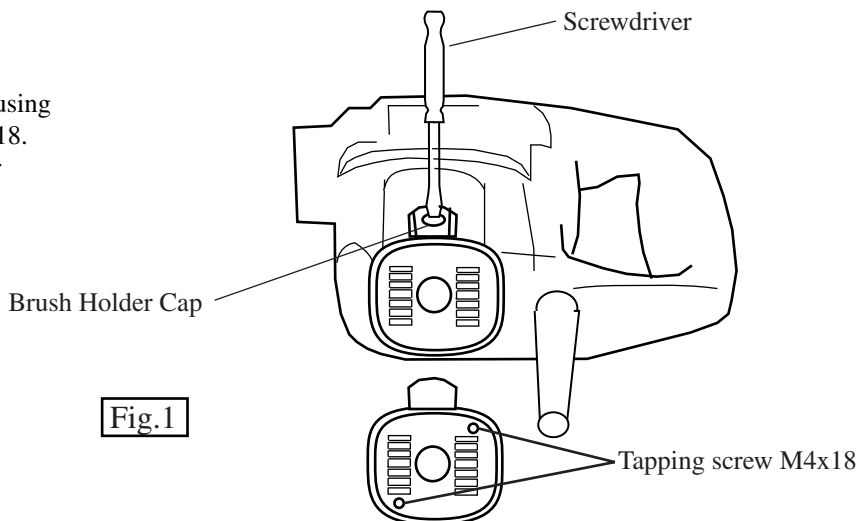

- (2) Take off the handle and controller cover by loosening 2 pcs. of hex socket hd. bolt M6x40 and 4 pcs. of hex socket hd. bolt M6x30.

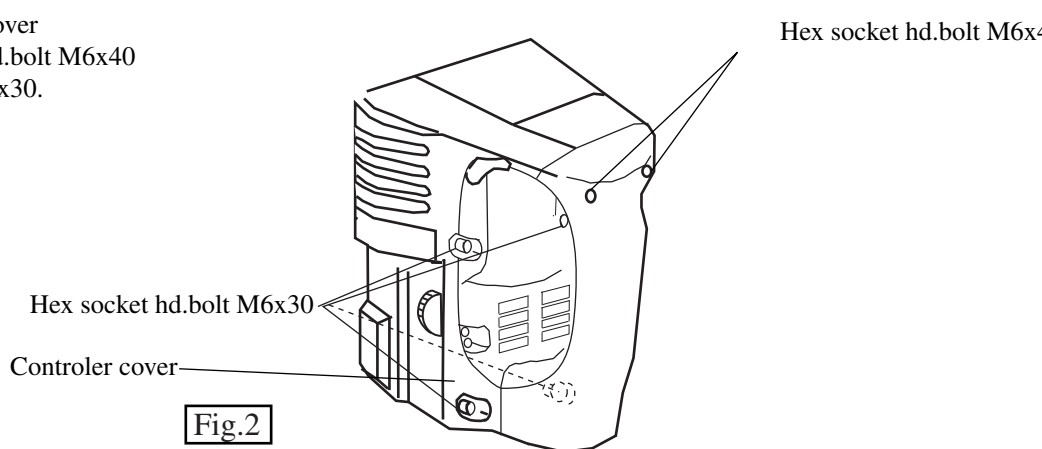

- (3) Dismount the motor housing by loosening 4 pcs. of hex socket hd. bolt M6x40.

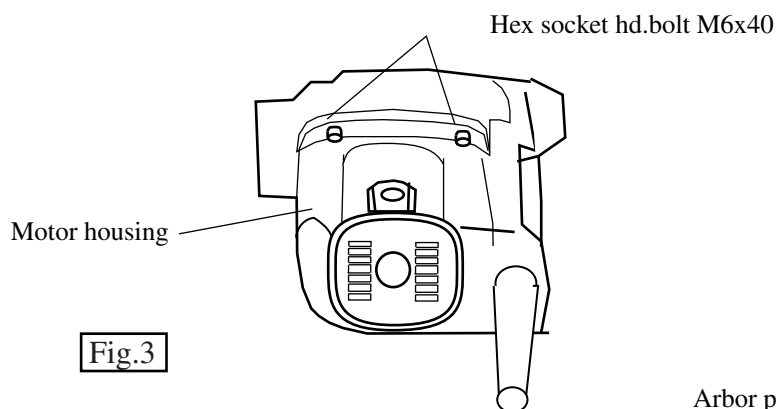

- (4) Support the machine with the repairing jig No. 1R023, 1R218 and 1R022. Put a round stick (repairing jig No. 1R234 or 1R235) on the armature. The armature can be removed from the motor housing by pushing the above round stick with arbor press.

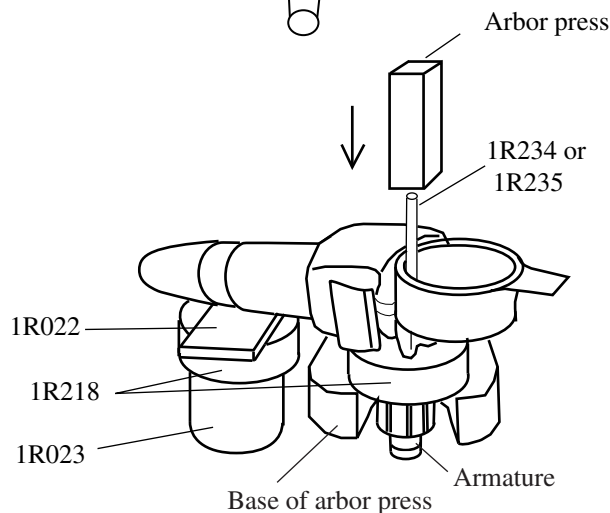

► **Repair**

(5) Removing ball bearing 6304LLU from crank shaft.

Insert the repairing jig 1R234, 1R240 and 1R241 into the arbor on the crank shaft as per the following illustration. And then, press with arbor press. So, Ball bearing 6304LLU can be removed.

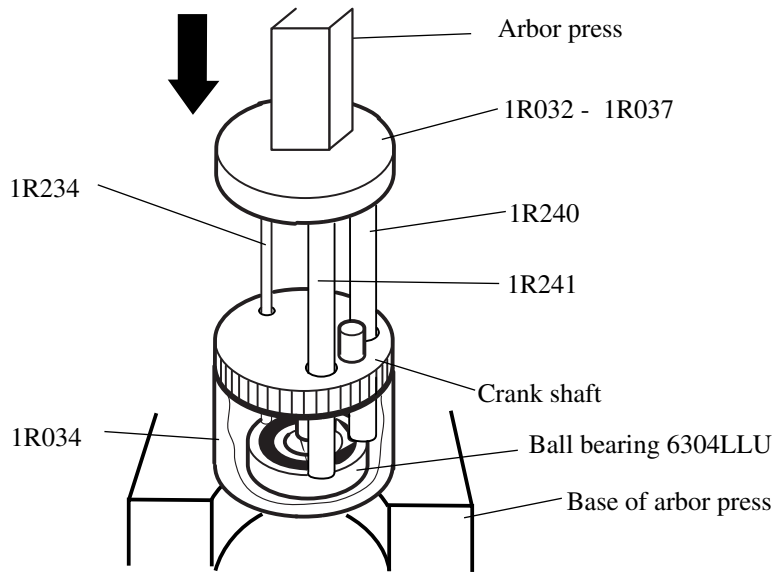

Fig.5

(Mounting)

Make sure that the gears engage each other, before pressing the armature with arbor press into crank housing.

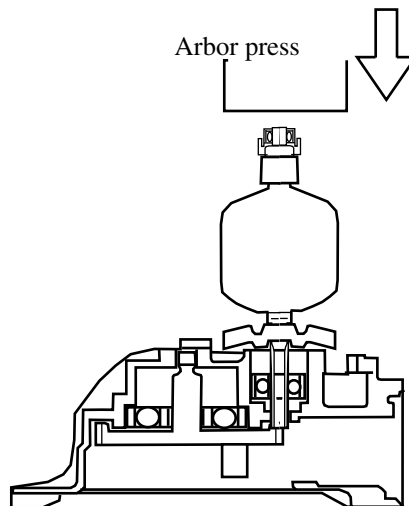

Fig.6

<2> Repairing on chuck section

Repairing on chuck section has to be made with installing controller cover, because it is difficult to keep the machine standing without it.

(Dismounting)

- (1) Pull tool holder housing down in the direction of the motor housing.
- Dismount tool holder cap.

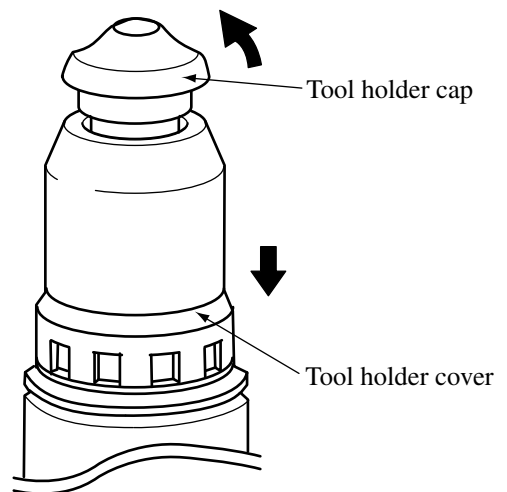

Fig.7

- (2) Pulling tool holder cover down in the direction of the motor housing, slide the cut of ring spring 29 in the direction of the cut of tool holder cover. And expand the cut of ring spring 29 with repairing tool No.1R212, lifting it with driver as illustrated in Fig.8.

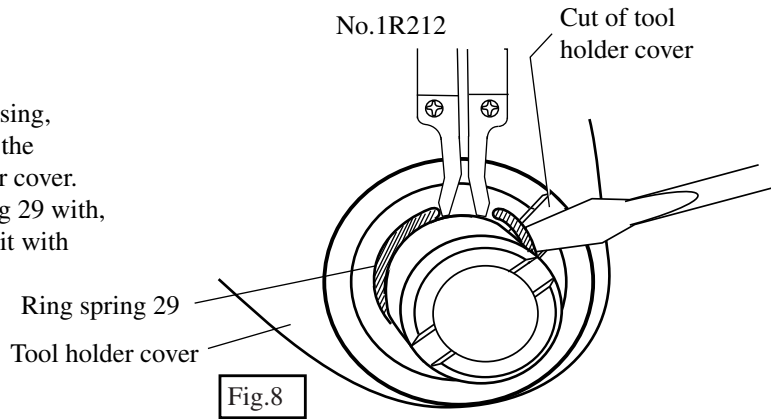

Fig.8

- (3) Tool holder, roller guide and pin 6 can be removed as a set, with removing ring spring 29. Roller guide can be removed from tool holder cover, with taking off pin 6.

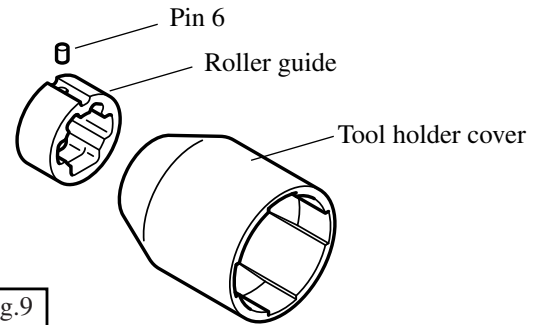

Fig.9

<3> Repairing of piston and striker

Take off only handle, not remove controller cover.
(Dismounting)

- (1) Take off change ring after removing chuck section. And then, take off ring spring 46 with pawl for retaining ring. Dismount housing cover.

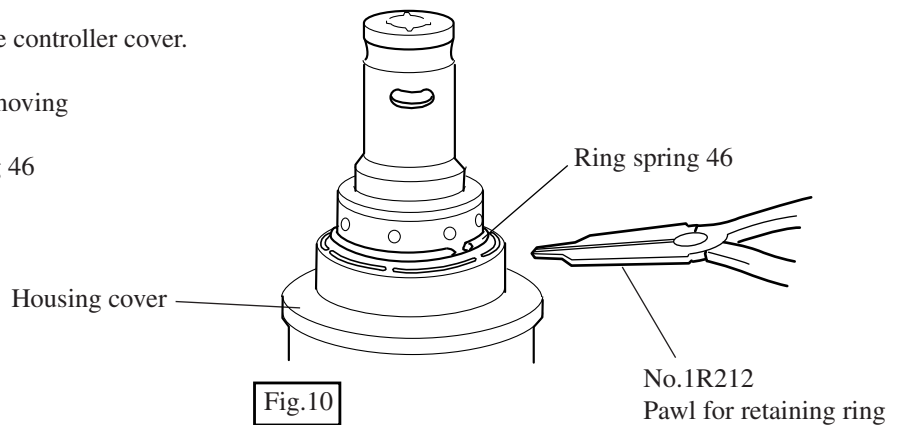

Fig.10

- (2) Loosen 4 pcs. of hex socket head bolt M8x30. Then barrel can be removed together with tool holder.

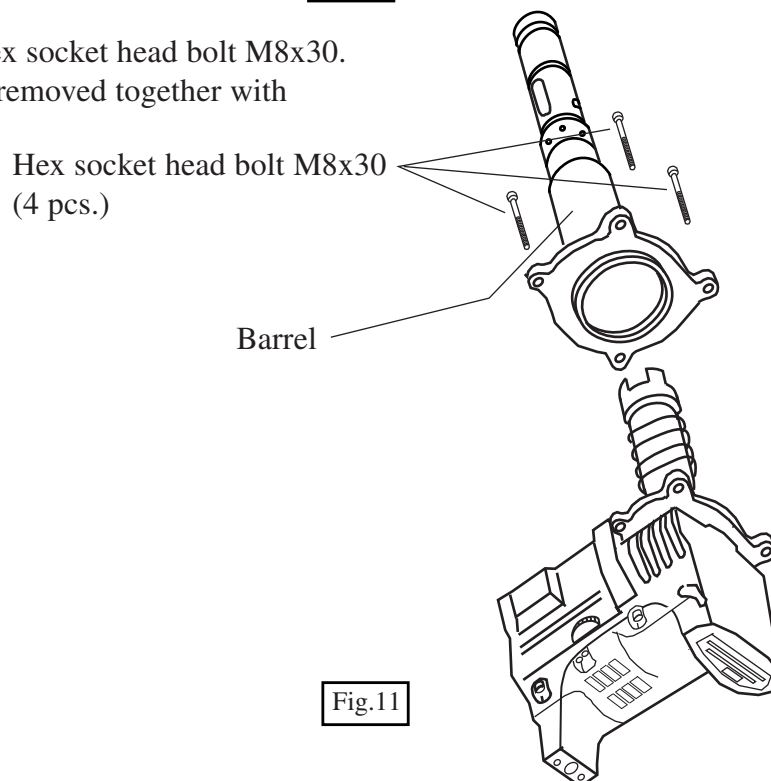
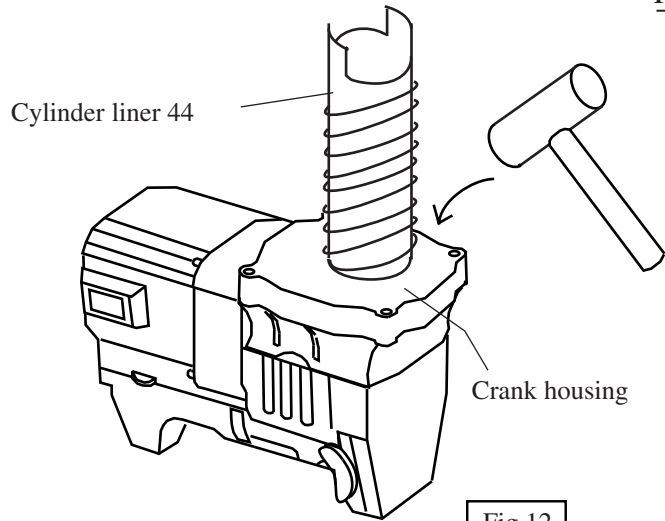

Fig.11

- (3) Hold cylinder liner 44 with hand and strike crank housing with plastic or wooden hammer.
Then the cylinder liner 44 can be removed from the machine.



(Assembling)

- (1) Assemble slide sleeve 49, ring 49 and compression spring 50 to cylinder liner 44. And then, put the cylinder liner 44 on piston. Mount the cylinder liner to the crank housing by pressing it with hand. Insert striker into the cylinder liner from the bit-installing side.

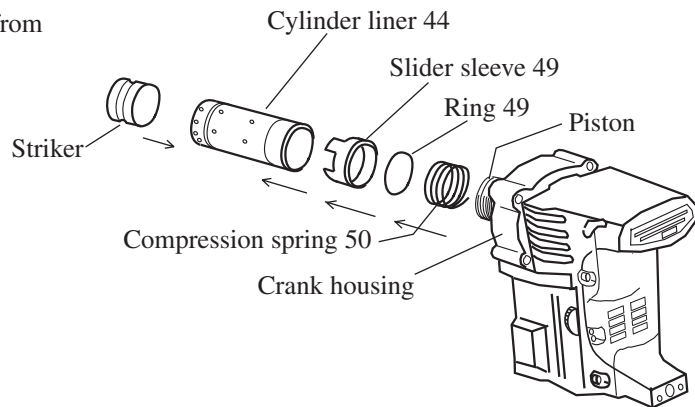

- (2) Adjust the convex of tool holder cap to the concave of tool holder cover. Make sure that tool holder cap does not turn after assembling.

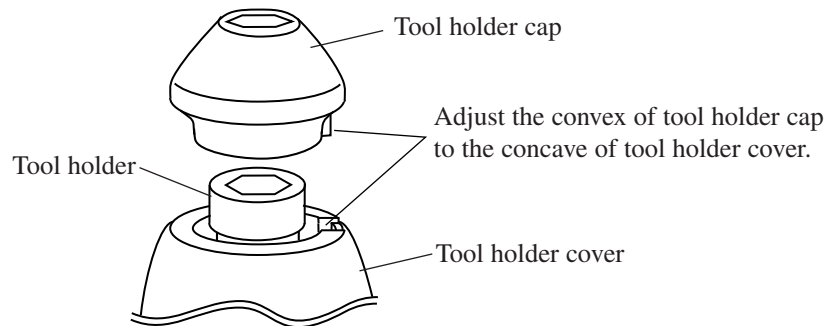

<4> Repairing of tool holder

Take off only handle, not remove controller cover.

(Dismounting)

Take off flat washer 37 after removing ring spring 34.

Remove tool holder from barrel by pressing .

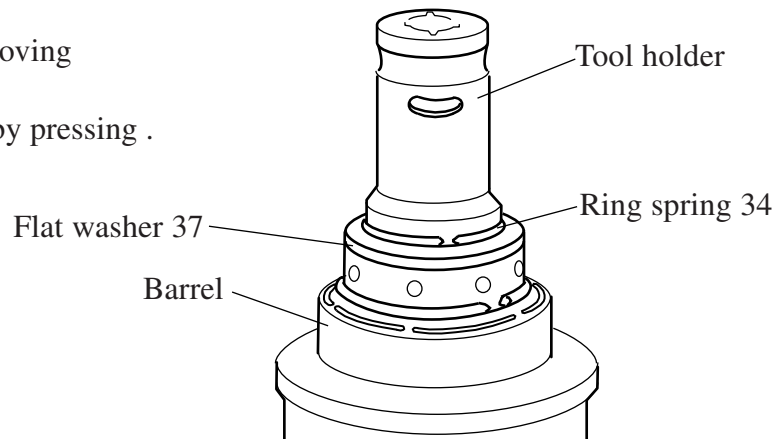

(Assembling)

- (1) Assemble tool holder to barrel after inserting impact bolt as illustrated in Fig.16.

(Note)

Make sure, that urethane ring 43 and O ring 38 are assembled to tool holder in advance.

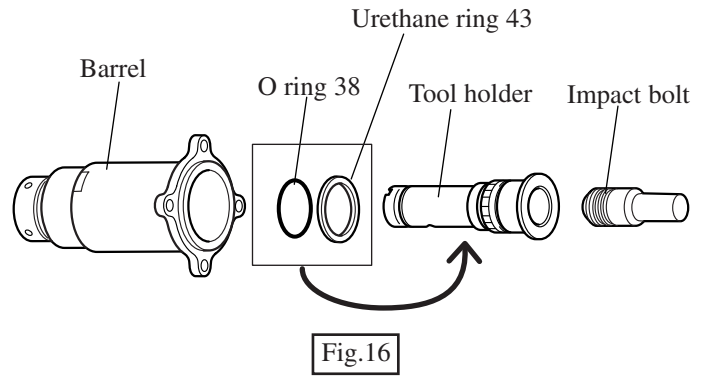

- (2) Assemble flat washer 37 to tool holder after assembling tool holder to barrel. And then, fix flat washer 37 with ring spring 34.

(Note)

The mark, " UP " has to be faced to the bit installing side as illustrated in Fig.17A.

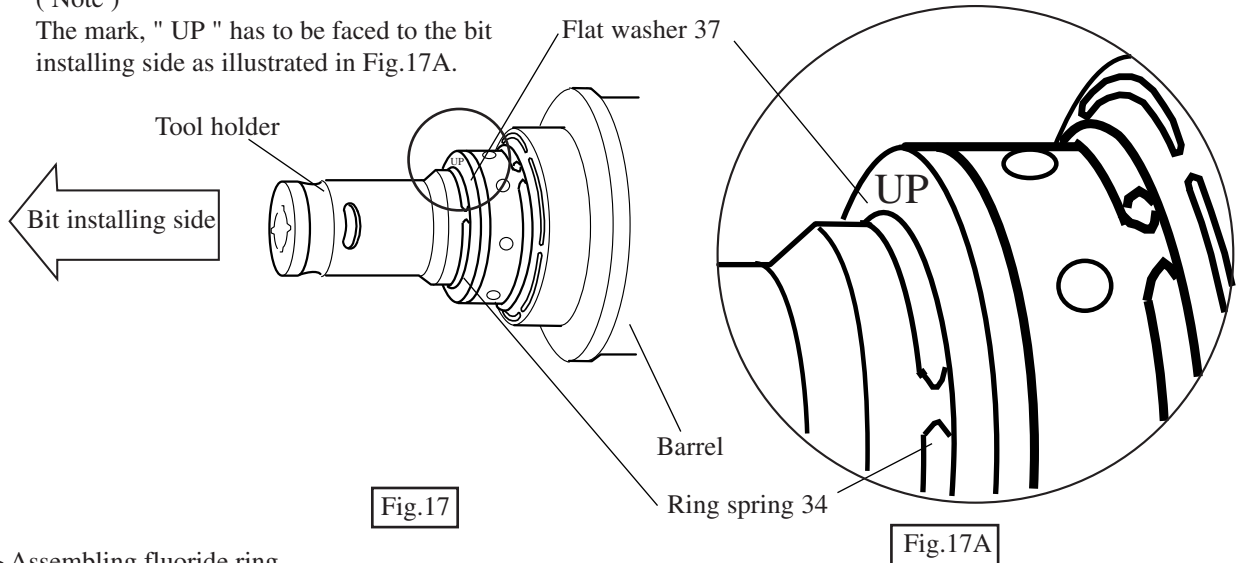

< 5> Assembling fluoride ring

(Assembling)

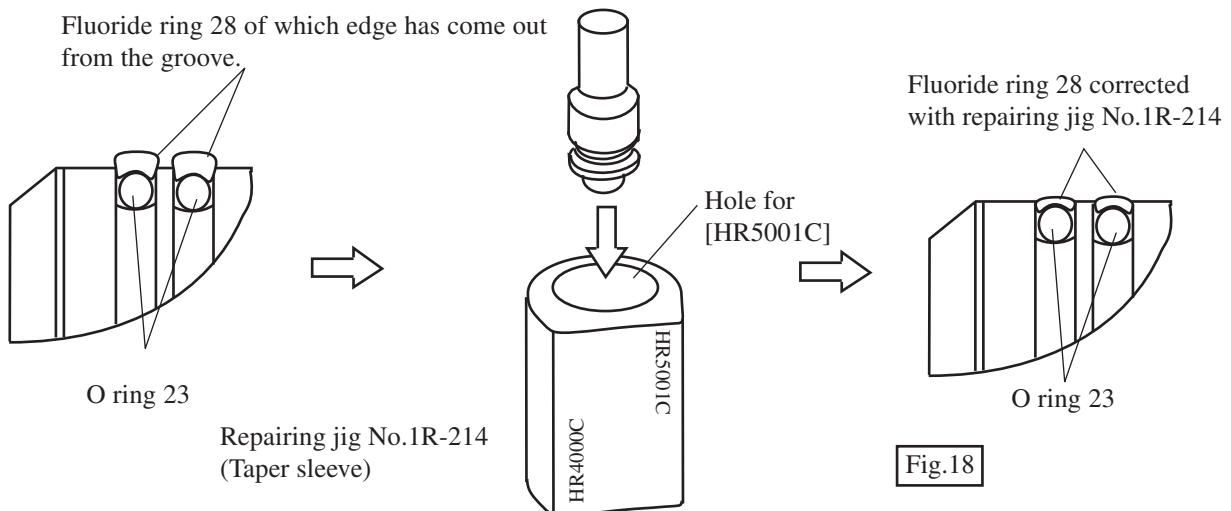

- (1) Fluoride ring 28, just after assembled, can not be fit precisely along the groove on the impact bolt. The edge come out from the groove.
- (2) Insert the impact bolt on which the fluoride ring 28 is attached, into repairing jig No.1R-214. At this time the impact bolt has to be inserted from the hole for [HR5001C] And then, keep the impact bolt in the repairing jig approx. 10 sec for correction of fluoride ring 28.
- (3) Pay attention, not to damage fluoride ring 28, when the impact bolt is inserted into tool holder.



▶ Repair

< 6> Mounting of barrel

Take off only handle, not remove controller cover.

- (1) Set the  of the guide ring on the  of flat washer 49.
Mount the above guide ring and flat washer 49 on the 3 prongs of slide sleeve 49.
- (2) Set collared ring 24 ,rubber ring 25 and impact bolt guide on the 3 prongs of slide sleeve 49.
- (3) Set barrel (with tool holder) on the cylinder liner 44 gently paying attention to keep collared ring 24, rubber ring 25 and impact bolt guide on the slide sleeve's edge.
Assemble compression spring 50 to crank housing by pressing it.

< Remarks>

Pay attention to the position of flat part on barrel as per the following illustration.

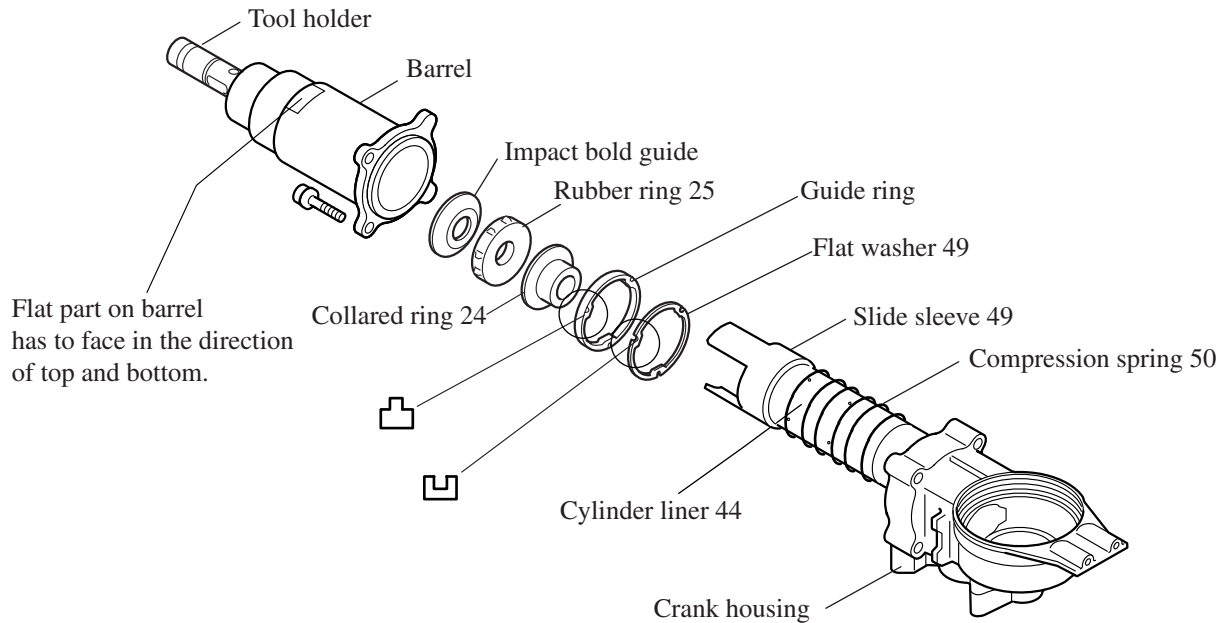

Fig.19

< 7> Mounting of controller cover

Set switch trigger in  of switch lever.

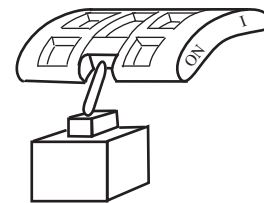

Fig.20

< 8 > Grease

Change of grease

Change grease to fresh one when carbon brush is changed.

- (1) Idle the machine for several minutes in order to warm up.
- (2) Take off the handle and controller cover
by loosening 2 pcs.of hex socket hd.bolt M6x40
and 4 pcs.of hex socket hd.bolt M6x30.
And then, crank housing appears.

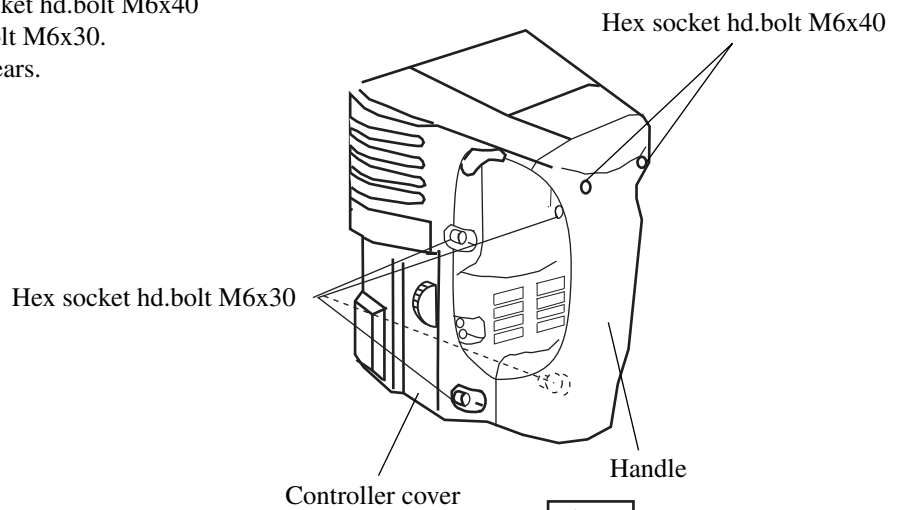
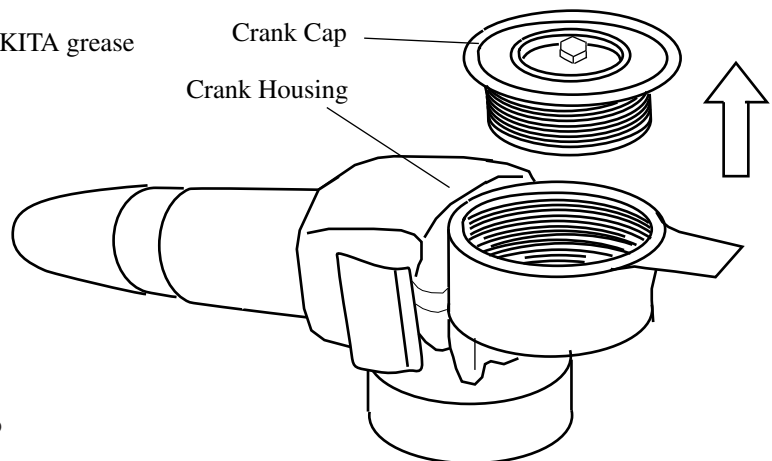

Fig.21

- (3) Take off crank cap.
- (4) Gather the grease softened by warming up, into the crank housing by facing the tool holder cap side to upward.
- (5) Wipe up the grease in the crank housing with cloth. And then, apply fresh MAKITA grease No.00 by 30g.



< Remarks >

The fresh grease to be applied has to be limited to 30 g.
Over application can be cause of trouble.

Fig.22

* The parts to be greased with MAKITA grease No.OO.

Put grease on the following parts in order to protect parts and machine from unusual abrasion and overheating.

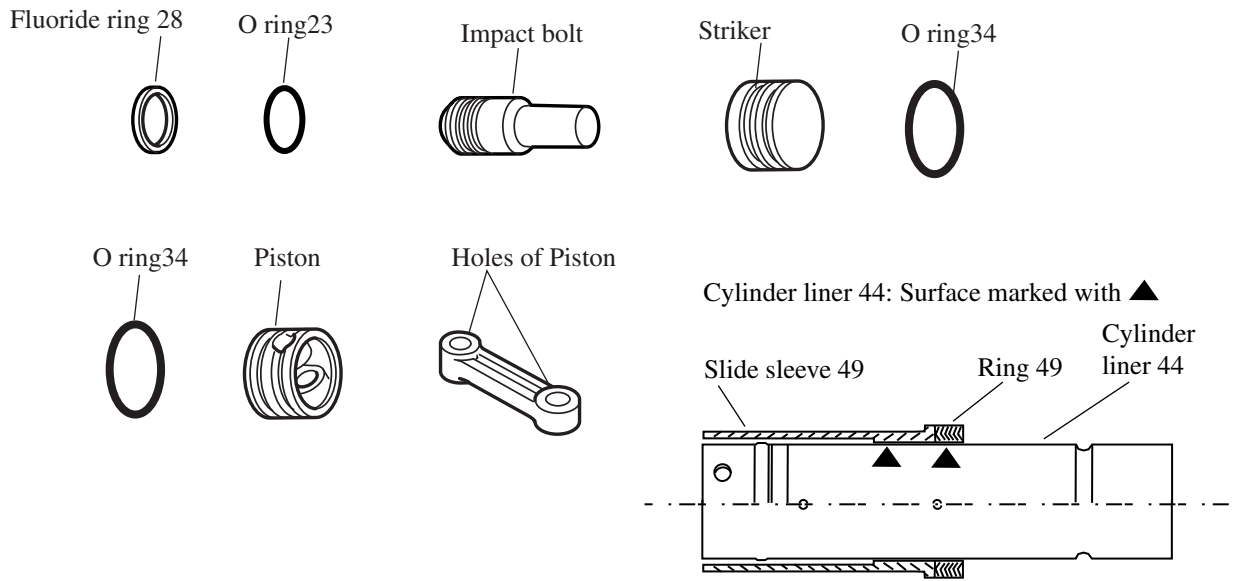

Barrel : Inner part marked with ▲ and ▨ .

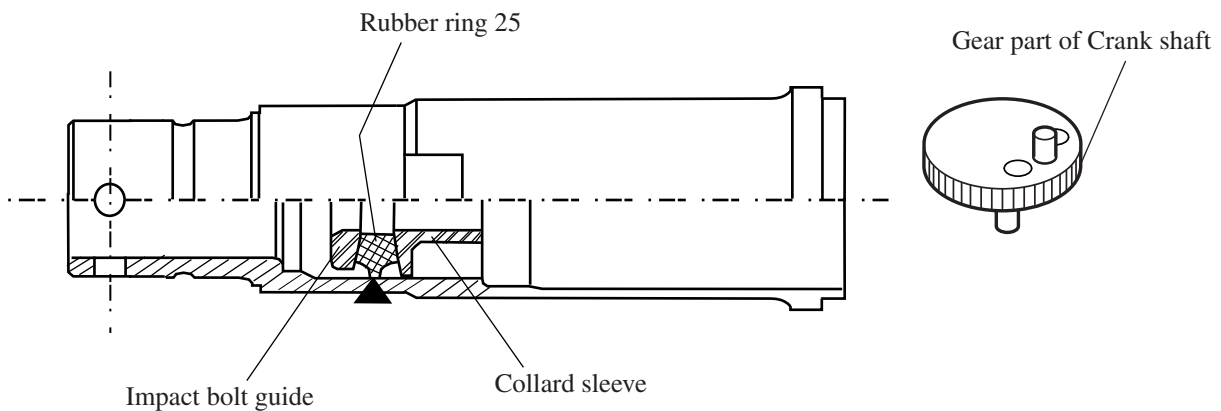

* The parts to be greased with MAKITA grease No.2.

Put grease on the following parts in order to protect parts and machine from unusual abrasion and overheating.

Tool holder and its holes
for roller 23 and steel ball 5.6.

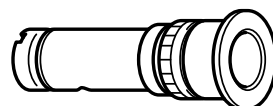

< 9 > Maintenance

It is recommended to change carbon brush every 140 hours operation. When changing carbon brush, we recommend you to change the following parts together.

- * Grease in crank housing.
Apply fresh grease approx. by 30g. (See P 10 / 14.)
- * Urethane ring 43 and roller 12 to be assembled to (32) tool holder
- * Fluoride ring 28 and O ring 23 to be assembled to (36) impact bolt

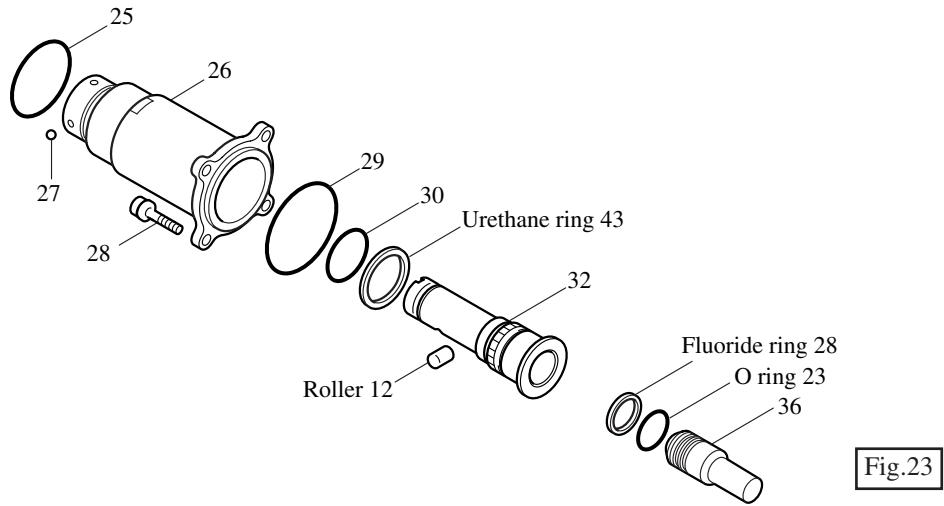

- * Rubber ring 25 to be assembled to cylinder liner 44 unit (42: cylinder liner 44 and 43:slide sleeve)

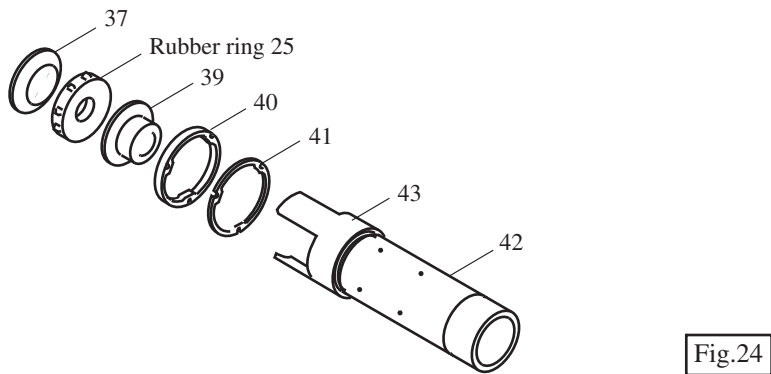

- * O ring 34 to be assembled to (49) striker
- * O ring 34 to be assembled to (54) piston
- * O ring 36 to be assembled to (54) piston

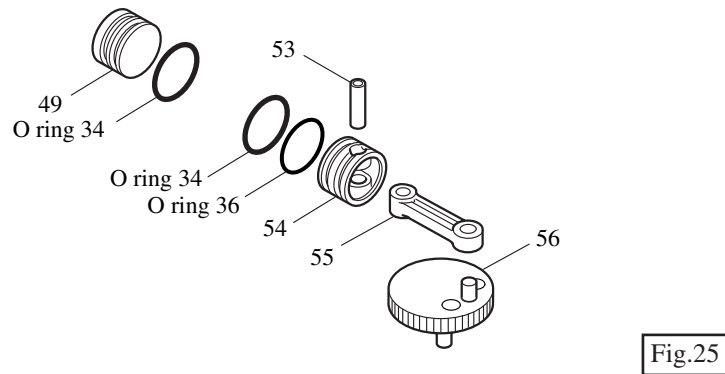

▶ Circuit diagram

This terminal is to be connected to brush holder mounted on opposite side of control dial.

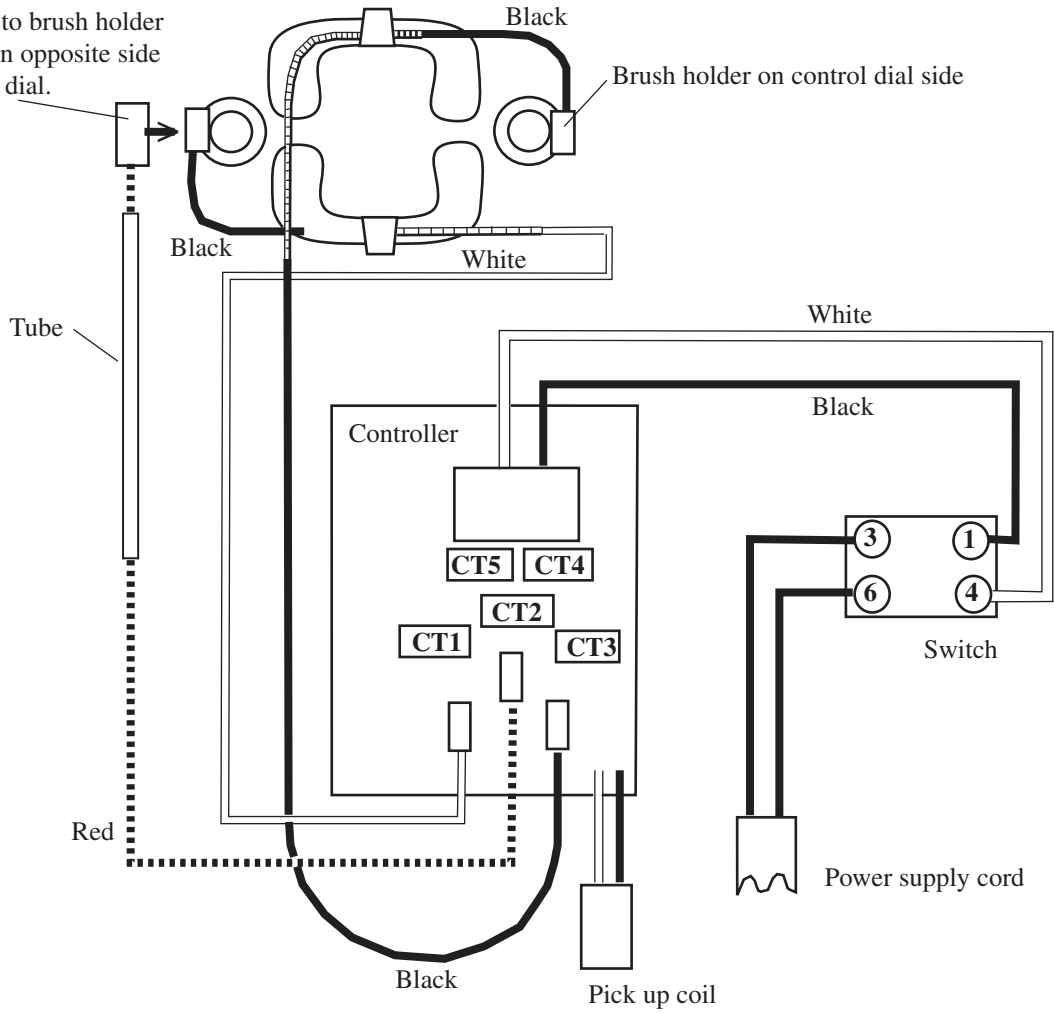

Fig.26

▶ Wiring diagram

Lead wire "(Red)" has to be passed through rib A as illustrated in Fig.27.

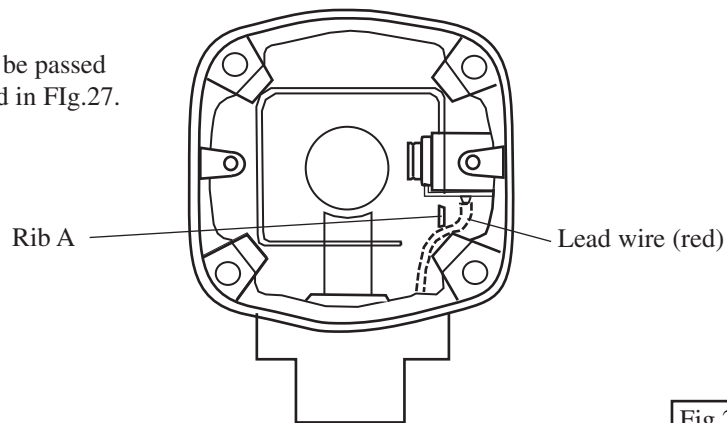

Fig.27

Lead wire from field (Black) and (White) has to be fixed by lead holder as per the illustration.

Lead wires of pick up coil have to be passed through rib B. At this time these 2 lead wires have not to be crossed each other.

