

# TECHNICAL INFORMATION



PRODUCT

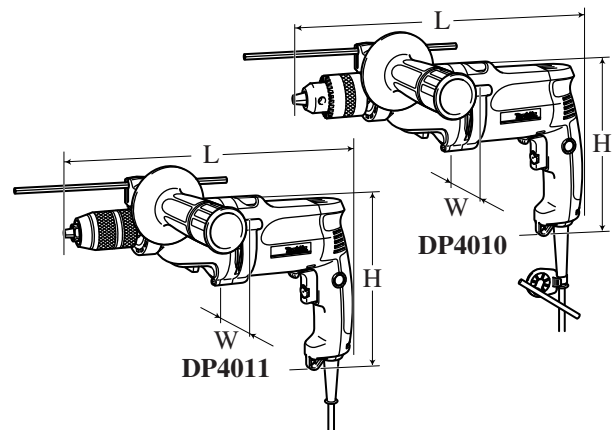
P 1/8

**Model No.** ▶ DP4010, DP4011

**Description** ▶ 2-Speed Drill 13mm (1/2")

## CONCEPT AND MAIN APPLICATIONS

- Models DP4010 and DP4011 have been developed as 13mm (1/2") Drill for professional users, featuring:
- \*2-speed gear selection with variable speed in each range for a wide range of applications
  - \*Extra-rigid cylindrical motor housing
  - \*Sturdy aluminum gear housing



Dimensions: mm (")	
Length (L)	347 (13-5/8)
Width (W)	70 (2-3/4)
Height (H)	220 (8-5/8)

## ► Specification

Voltage (V)	Current (A)	Cycle (Hz)	Continuous Rating (W)		Max. Output (W)
			Input	Output	
110	6.9	50/60	720	360	660
120	6.6	50/60	---	360	660
220	3.4	50/60	720	360	660
230	3.3	50/60	720	360	660
240	3.2	50/60	720	360	660

Model			DP4010	DP4011
No load speed: min - max rpm	High		0 - 2,900	
	Low		0 - 1,200	
Drill chuck type			Keyed	Keyless
Chuck capacity: mm (")			1.5 - 13 (1/16 - 1/2)	
Capacities: mm (")	Steel	High	8 (5/16)	
		Low	13 (1/2)	
	Wood	High	25 (1)	
		Low	40 (1-9/16)	
Reverse switch			Yes	
Torque limiter			Yes	
Protection against electric shock			Double insulation	
Power supply cord: m (ft)			2.5 (8.2)	
Net weight: kg (lbs)			2.2 (4.9)	

## ► Standard equipment

- Chuck key S-13 ..... 1 (for **DP4010**)
- Key holder 12 ..... 1 (for **DP4010**)
- Side handle ..... 1
- Depth gauge ..... 1

**Note:** The standard equipment for the tool shown above may differ by country.

## ► Optional accessories

- Metal drill bits 1.5 - 13 mm (1/16 - 1/2")
- Wood drill bits 3 - 40 mm (1/8 - 1-9/16")
- Center drill for hole saw
- Hole saws 16 - 90 mm (5/8 - 3-1/2")
- Metal borers 14 - 35 mm (9/16 - 1-3/8")
- Depth gauge
- Wrench 9
- Side handle
- Drill chuck
- Chuck key S-13 (for **DP4010**)
- Drill stand Type 43

## ► Repair

**CAUTION: Remove the bit from the machine for safety before repair/ maintenance in accordance with the instruction manual!**

### [1] NECESSARY REPAIRING TOOLS

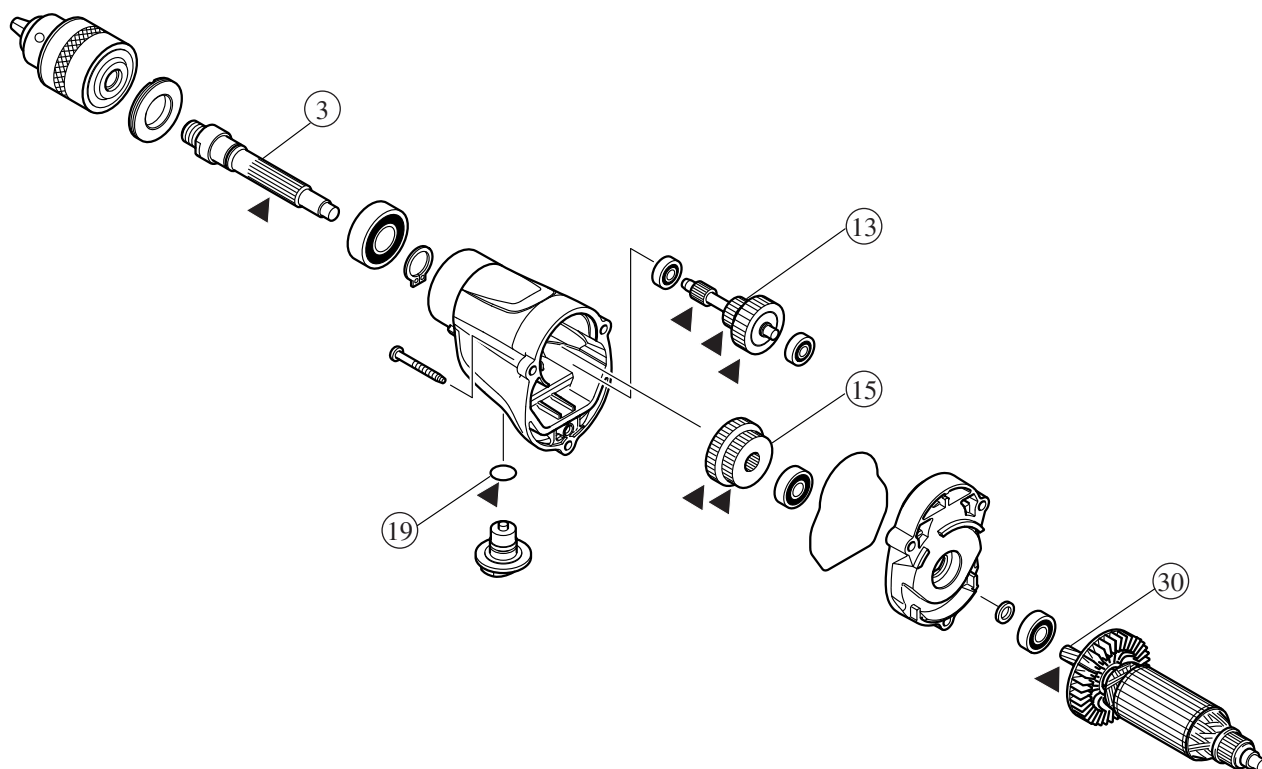
Code No.	Description	Use for
781024-2	Wrench 43	Removing the damaged Keyed-drill chuck
1R045	Gear extractor (large)	Removing Armature
1R139	Drill chuck extractor	Removing / Assembling Drill chuck
1R223	Torque wrench shaft 20-90N.m	
1R224	Ratchet head 12.7 for 1R223	
1R298	Hex. bar 10 with square socket	
1R269	Bearing extractor	Removing Ball bearings
1R316	Wrench for bearing retainer	Removing / Assembling Bearing retainer

### [2] LUBRICATION

Apply 30g in total of Makita grease N. No.1 to the following portions designated with the black triangle to protect parts and product from unusual abrasion.

Item No.	Description	Portion to lubricate
③	Spindle	Spline portion
⑬	Gear complete	Gear teeth
⑮	Spur gear 29-37	Gear teeth
⑳	Armature	Gear teeth
⑲	O ring 12	Whole portion

**Fig. 1**



## ► Repair

### [3] DISASSEMBLY/ASSEMBLY

#### [3] -1. Drill Chuck

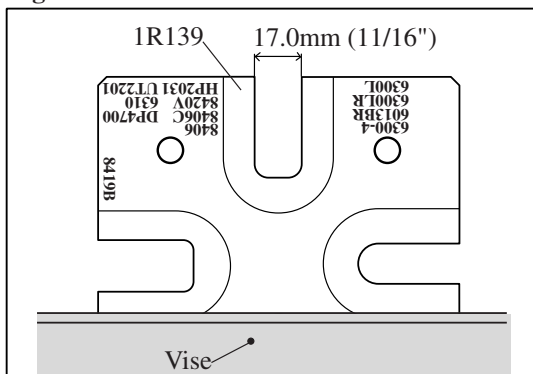
##### DISASSEMBLING

- 1) Secure 1R139 firmly with Vise as illustrated in **Fig. 2**.
- 2) Fix Spindle on 1R139 by inserting Spindle into the U-shaped notch on 1R139 with the flat sides of the Spindle facing the edges of the notch. And then remove Drill chuck by turning it counterclockwise with 1R223, 1R224 and 1R298. (**Fig. 3**)
  - Use Pipe wrench to remove the Drill chuck, if the sleeve of Drill chuck does not turn because of some troubles with Drill chuck. Grip the periphery of the sleeve with wrench, and turn wrench counterclockwise.
  - The keyed Drill chuck of DP4010 can be removed using a Wrench 43 (781024-2).

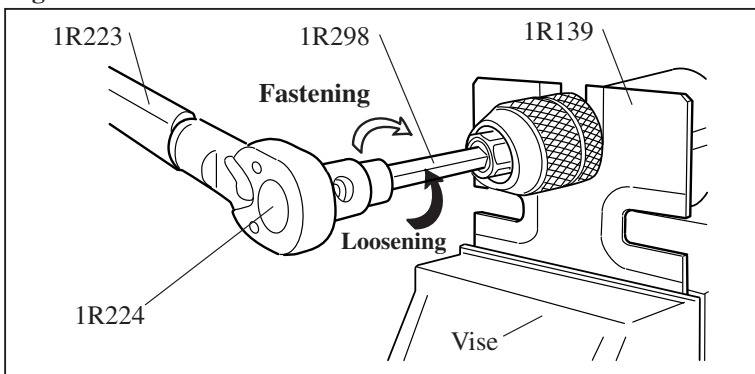
##### ASSEMBLING

When fastening the Drill chuck to the Spindle, set the torque of 1R223 to 35.7 to 45.9 N.m.

**Fig. 2**



**Fig. 3**



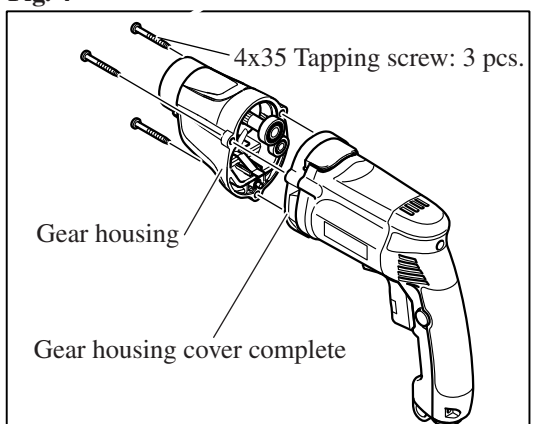
#### [3] -2. Gear Section

##### DISASSEMBLING

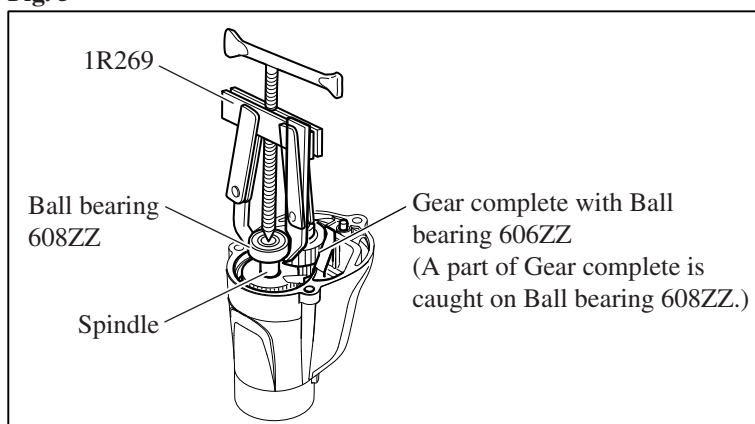
- 1) Remove three 4x35 Tapping screws, and Separate Gear housing from Gear housing cover complete. (**Fig. 4**)
- 2) Remove Ball bearing 608ZZ from Spindle with 1R269 (**Fig. 5**) and pull out Gear complete with Ball bearing 606ZZ. (**Fig. 6**)
 

**Note:** Gear complete with Ball bearing 606ZZ can not be pulled out without removing Ball bearing 608ZZ in advance.
- 3) After removing Lock plate, pull off Change lever B. (**Fig. 7**)
- 4) Remove Spur gear 29-37 from Spindle. Change plate B, Rack 12 and Pin 4 can be removed. (**Fig. 8**).

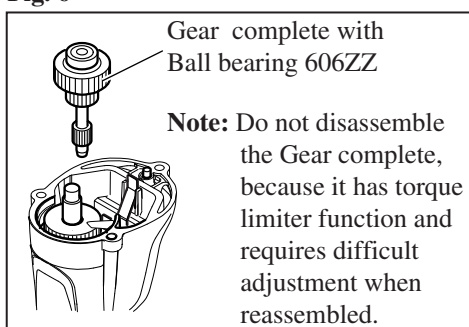
**Fig. 4**



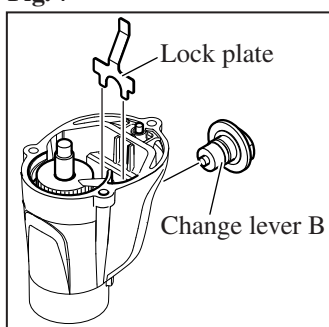
**Fig. 5**



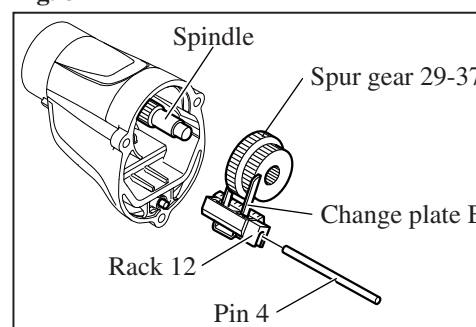
**Fig. 6**



**Fig. 7**



**Fig. 8**



## ► Repair

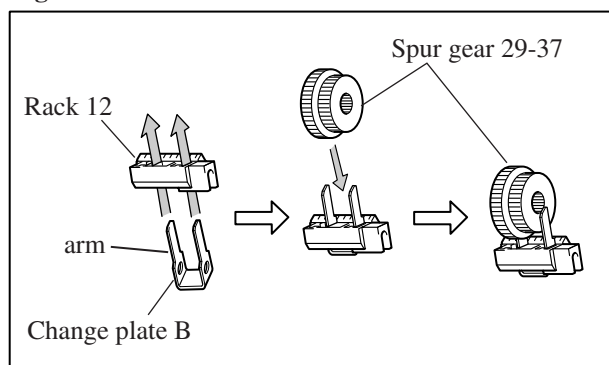
### [3] DISASSEMBLY/ASSEMBLY

#### [3] -2. Gear Section (Cont.)

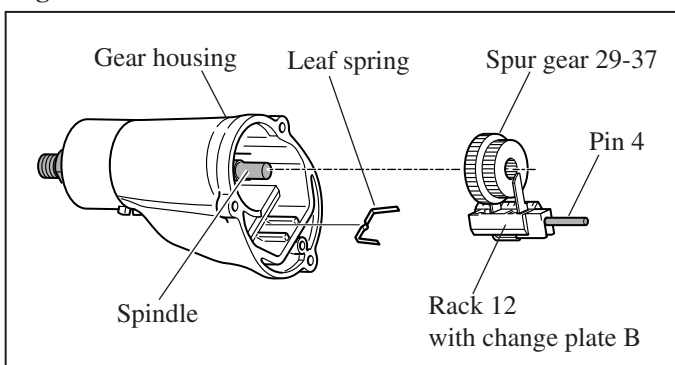
##### ASSEMBLING

- 1) Insert the arms of Change plate B through the slots in Rack 12, and then put Spur gear 29-37 between the arms of Change plate B. (**Fig. 9**)
- 2) Insert the Pin 4 into Rack 12. Install Spur gear 29-37 to Spindle together with the parts you have assembled to Rack 12. (**Fig. 10**)  
At this time, do not fail to set Leaf spring in place. (**Fig. 10**)

**Fig. 9**

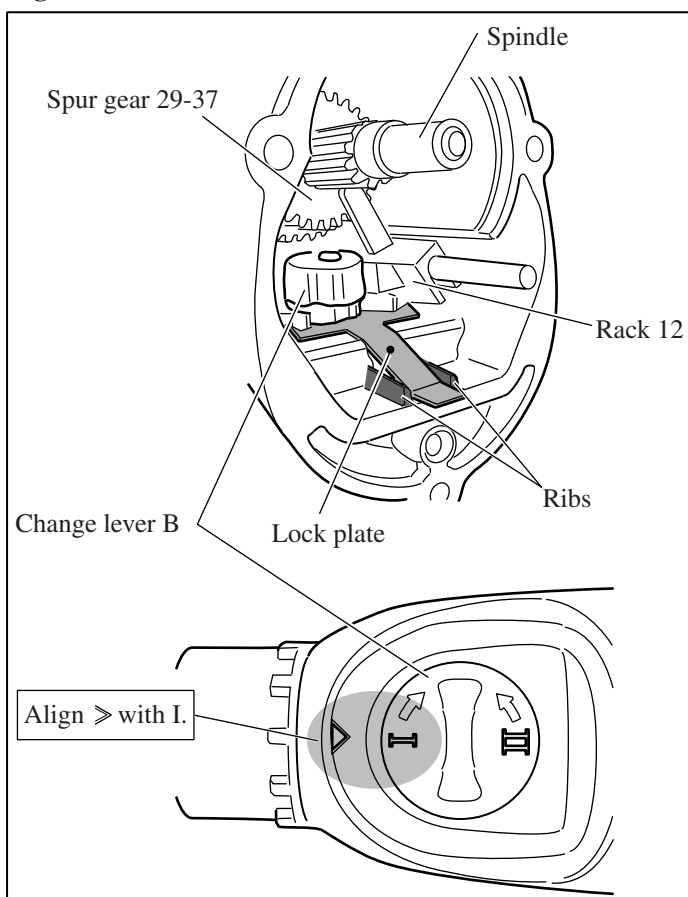


**Fig. 10**



- 3) Push Rack 12 into Gear housing until it stops.  
And then, install Change lever B on Gear housing with its "I" mark which indicates low speed aligned with the triangular mark on Gear housing. (**Fig. 11**)
- 4) Install Lock plate on Gear housing with its tail portion inserted between the ribs on Gear housing as illustrated in **Fig. 11**.
- 5) Assemble Gear complete with Ball bearing 606ZZ to Gear housing as illustrated in **Fig. 6**.

**Fig. 11**



## ► Repair

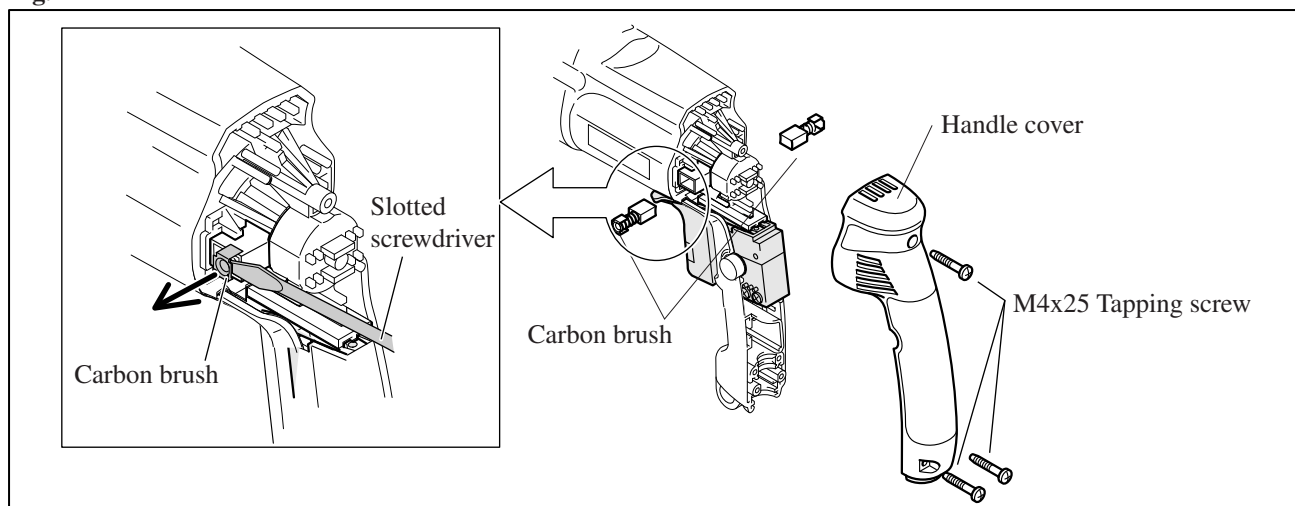
### [3] DISASSEMBLY/ASSEMBLY

#### [3] -3. Armature

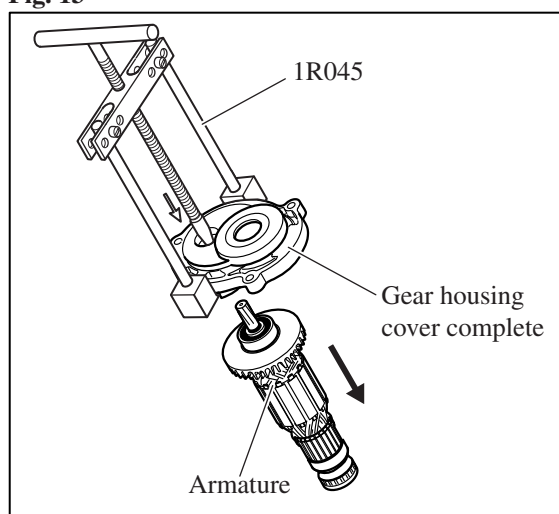
##### DISASSEMBLY

- 1) Disassemble Handle cover by removing Tapping screws. Then remove Carbon brush with slotted screwdriver (**Fig. 12**)
- 2) Remove Gear housing cover complete from Motor housing after removing Gear housing. (**Fig. 4**)  
Therefore, Armature comes out with Gear housing cover complete.
- 3) Remove Armature from Gear housing cover complete with 1R045. (**Fig. 13**)
- 4) The Ball bearings are removed from the both end of Armature shaft. (**Figs. 14 and 15**)

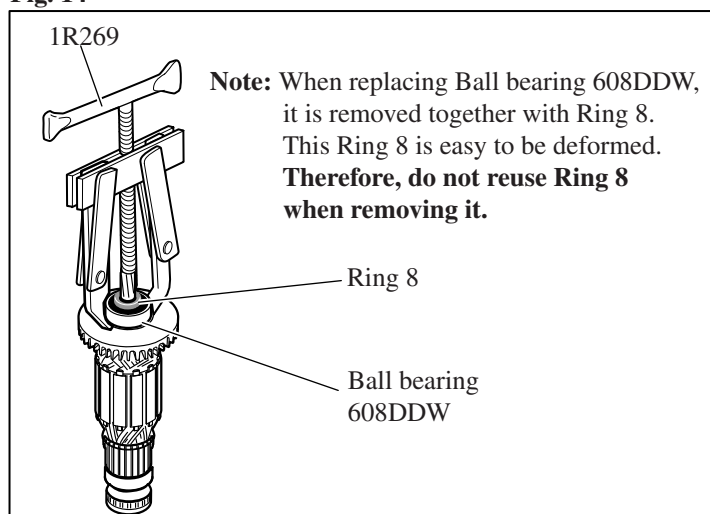
**Fig. 12**



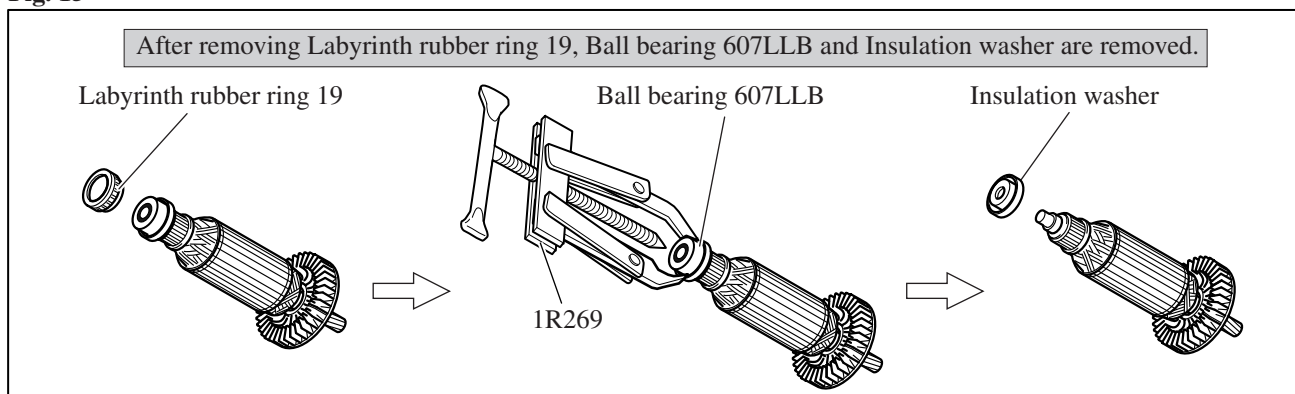
**Fig. 13**



**Fig. 14**



**Fig. 15**



##### ASSEMBLY

Do the reverse of the disassemble step.

## ► Repair

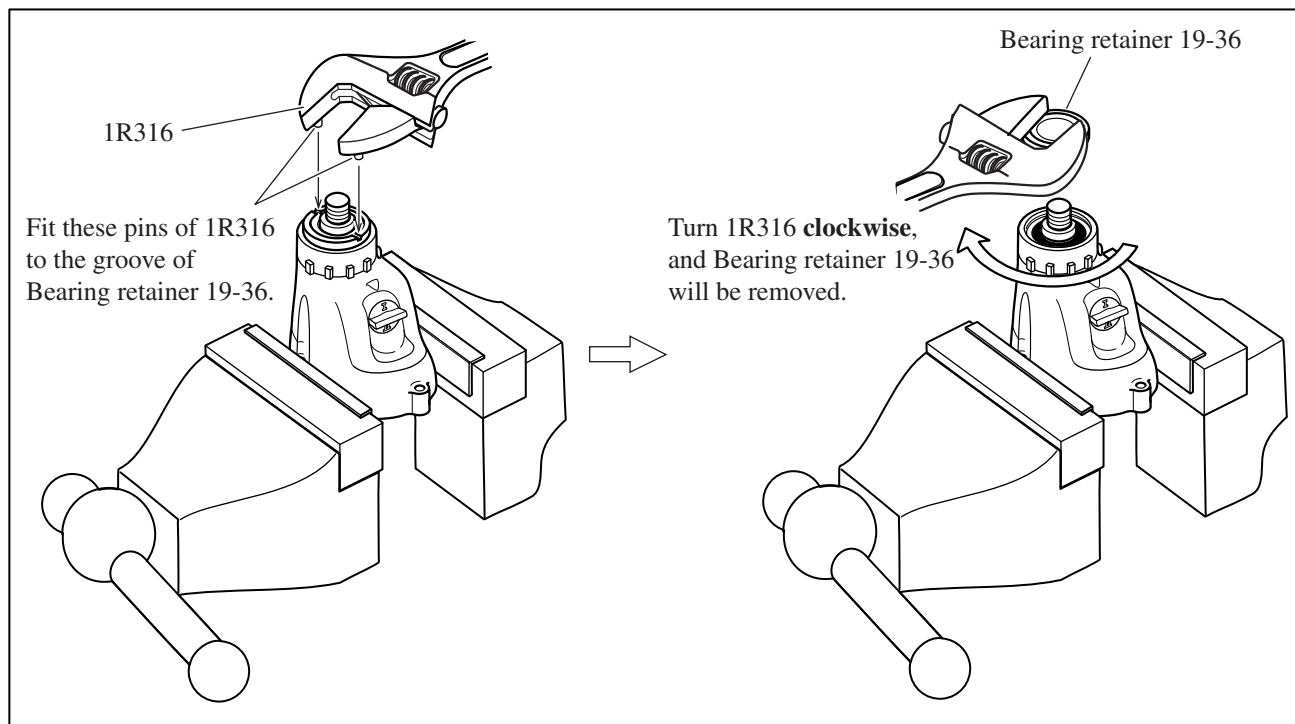
### [3] DISASSEMBLY/ASSEMBLY

#### [3] -4. Bearing Retainer 19-36

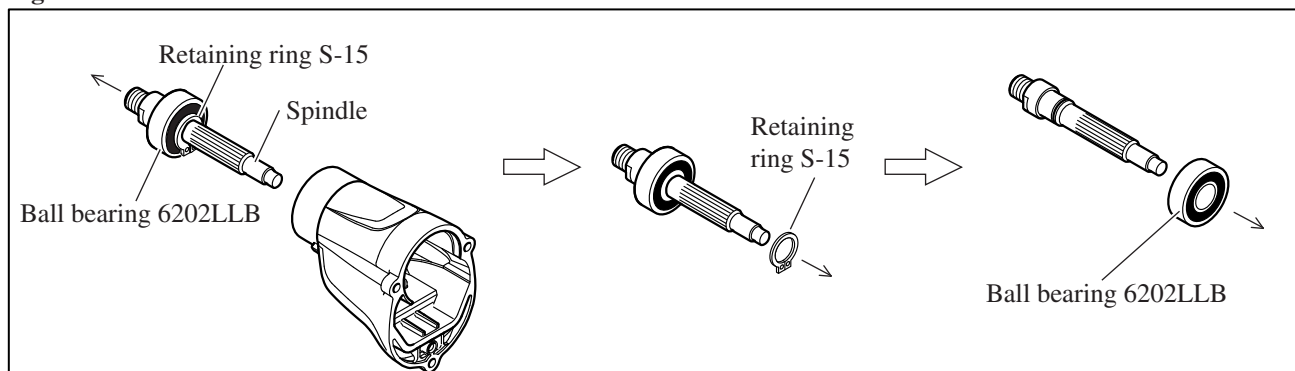
##### DISASSEMBLY

- (1) Remove Gear section from Gear housing. Refer to **Figs. 4 to 8.**
- (2) Remove Bearing retainer 19-36 with 1R316. (**Fig. 16**)
- (3) Ball bearing 6202LLB can be disassembled as illustrated in **Fig. 17.**

**Fig. 16**



**Fig. 17**

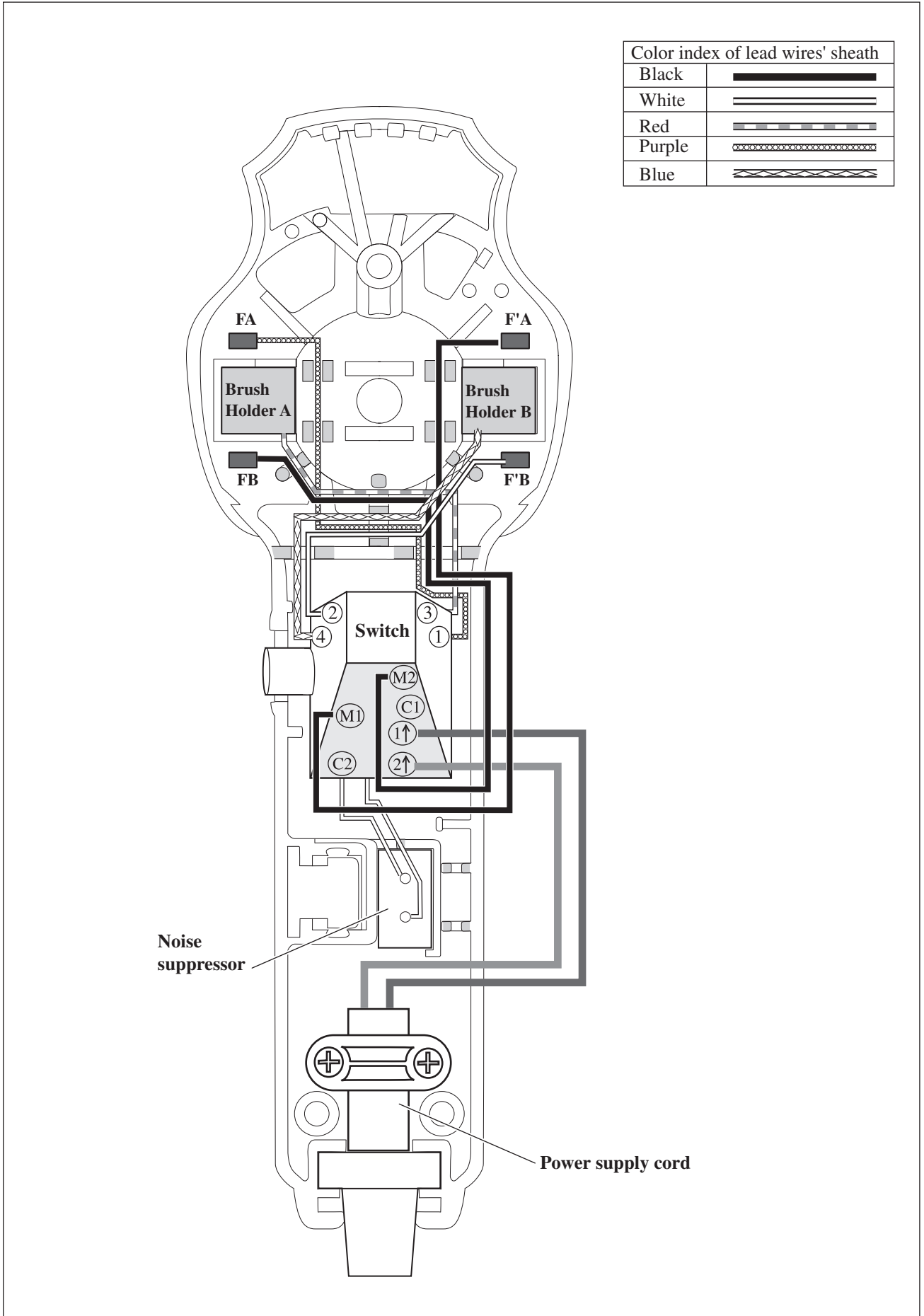


##### ASSEMBLY

Do the reverse of the disassembling step.

► **Circuit diagram**

**Fig. D-1**



► **Wiring diagram**

Fig. D-2

