

**Models No.** ▶ DC24SA

**Description** ▶ Charger

## CONCEPTION AND MAIN APPLICATIONS

This new charger allows you to charge new Ni-MH battery from 7.2V to 24V. This charger contains trickle charging function. Its brief benefits are listed below.

- The charging time for new 24V Ni-MH batteries is as follows.
  - \* B2417 / 1.7Ah : approx. 30 min.
  - \* B2430 / 3.0Ah ; approx. 60 min.
- Innovative computer controlled charging system realized most suitable charge by making the digital communication between charger and battery.
- Cooling system to keep the ideal temperature for charge.
- Power display for battery ; It displays the charging amounts of battery in two steps. (less than 80% or more than 80% of charge)
- The adapter ADP01 (optional acc.) enables to charge the existing 7.2V - 24V Ni-Cd and Ni-MH batteries, too.
- The adapter ADP02 (optional acc.) enables to refresh inactive batteries

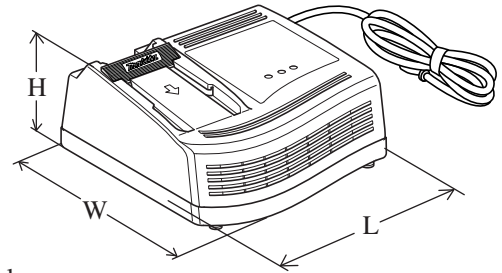

Dimensions : mm ( " )	
Width ( W )	175 (6-29/32)
Height ( H )	110 (4-5/16)
Length ( L )	215 (8-15/32)

## ► Specification

Voltage (V)	Output Current (A)	Cycle (Hz)	Continuous Rating (W)		Output Voltage (V)
			Input	Output	
120	D/C 6.5	50 - 60	135		D/C 7.2 - 12
220 - 240	D/C 6.5	50 - 60	135		D/C 7.2 - 12
230 - 240	D/C 6.5	50 - 60	135		D/C 7.2 - 12

## Charging time

			New battery		The existing battery (adaptor is required)
Voltage ( V )			7.2 - 18	19.2 - 24	7.2 - 18
Charging time	Ni-MH	3.0 Ah	35	60	40
		2.6 Ah	—	—	35
		2.2 Ah	—	—	30
		1.7 Ah	20	30	—
	Ni-Cd	2.0 Ah	—	—	20
		1.7 Ah	—	—	17
1.3 Ah		—	—	13	
Power display for battery			Yes		No
Cooling fan			Yes		No
Cord length : m (ft)			2.0 (6.6)		
Net weight :Kg (lbs )			1.7 (3.7)		

## ► Optional accessories

- \* Interchangeable adapter ADP01 for the existing batteries
- \* Refreshing adapter ADP02

<1> Reverse the charger and remove 4 tapping screws 4 x 20 after taking off cap 13. (See Fig.1.)

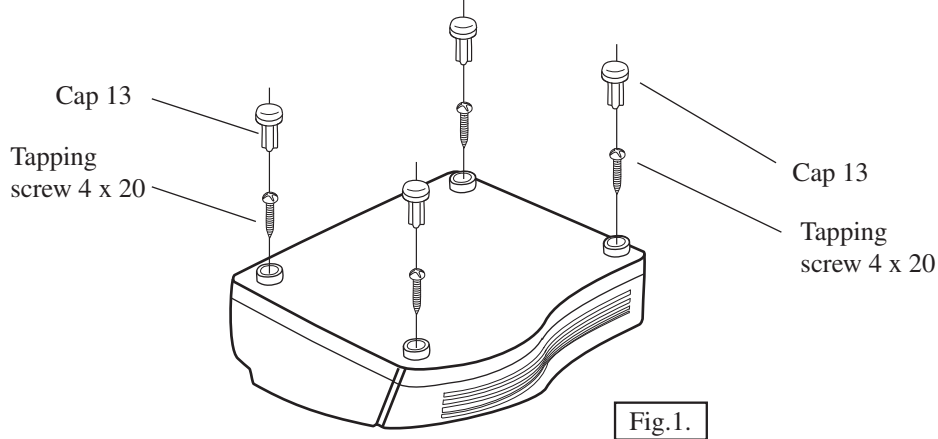

<2> Put the charger in the working position again, and remove charger case from circuit board complete. (See Fig. 2.)

<3> Circuit board complete can not be repaired. Because the circuit itself is molded on the board with the urethane resin. It has to be replaced as a " circuit board complete", which we have the following types.

- \* 120V Circuit board complete for low voltage area
- \* 220-240V Circuit board complete for high voltage area

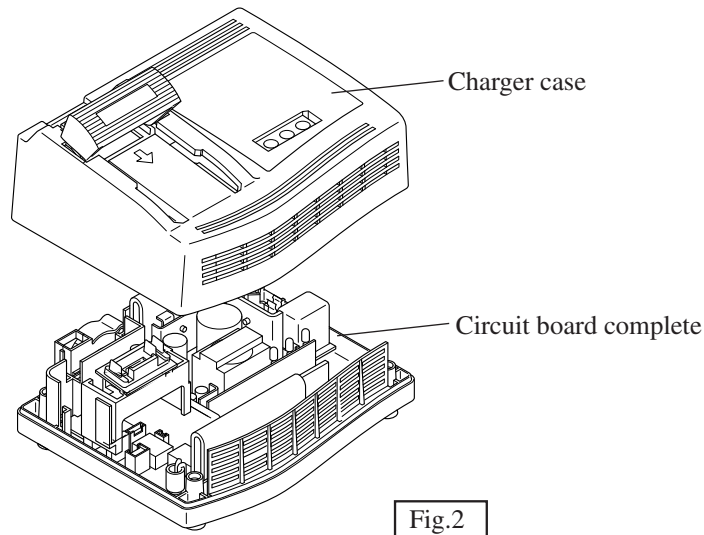

<4> Replacement of terminal unit

Disconnect the connector CN2 and CN3 from circuit board complete, and replace the broken terminal unit with the new one. Pay attention, not to lose compression spring 4.

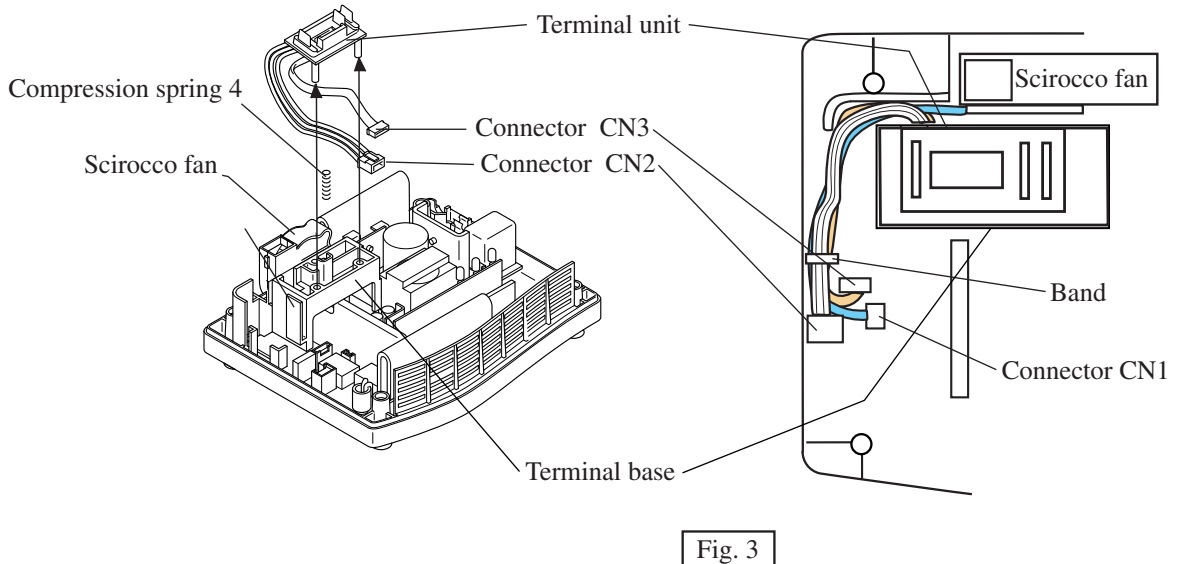

<5> Replacement of scirocco fan

Disconnect the connector CN1 from circuit board complete and replace the broken scirocco fan with the new one.  
(See Fig. 4.)

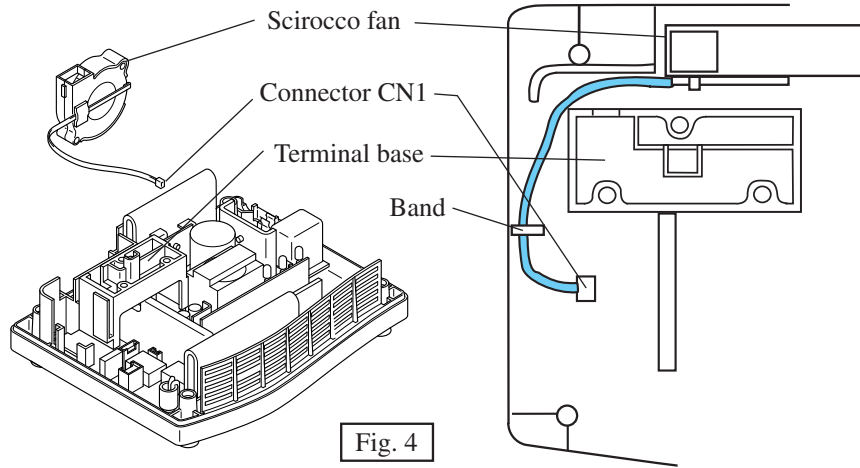

<6> Replacement of terminal cover

1. Remove the old terminal cover.
2. Attach torsion spring 14 on the new terminal cover as illustrated in Fig.5..
3. Hook the torsion spring 14 to the rib of charger case from its inside as illustrated in Fig. 6.
4. Hook the boss of terminal cover to the rib of charger case as illustrated in Fig.6.

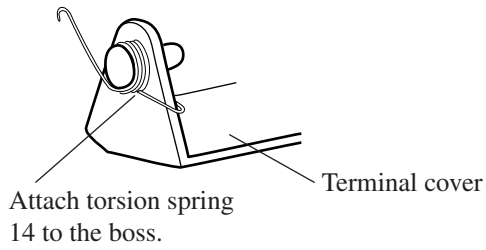

Hook the torsion spring 14 to the rib of charger case

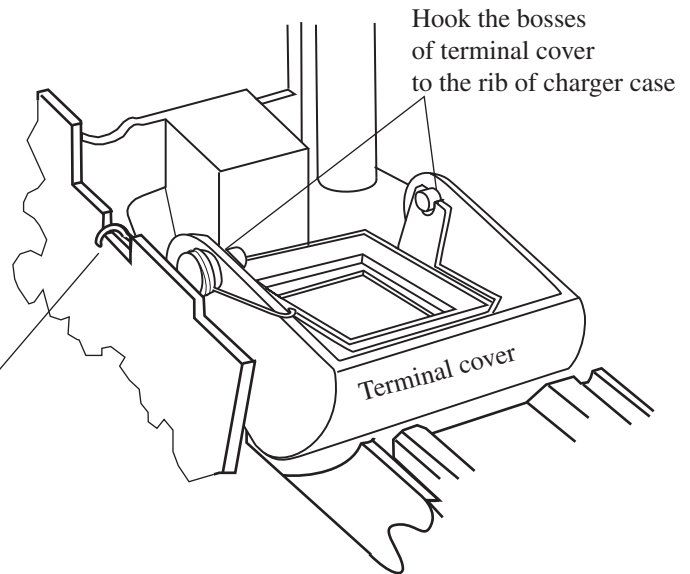

<7> Assembling terminal unit

Insert compression spring 4 into the hole of terminal base as illustrated in Fig. 7.

Insert 3 bosses of terminal unit into the holes of terminal base as illustrated in Fig. 7.

Pass the lead wires of terminal unit without slacking, along the portion marked with .

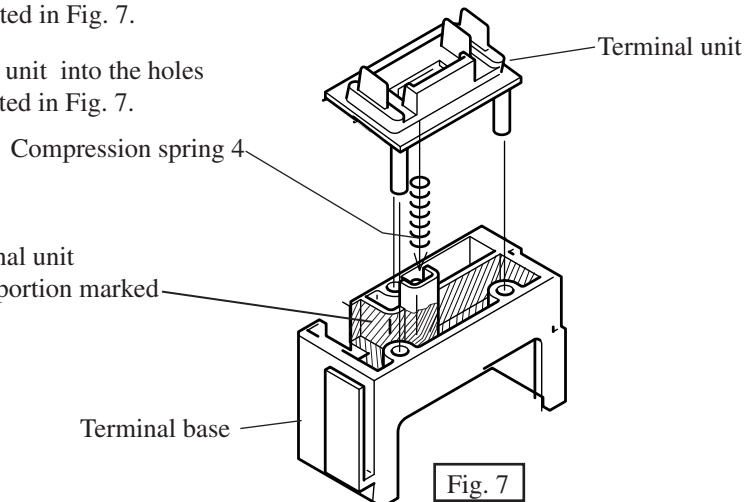

<8> Assembling cord

Hold the cord with labyrinth figured lead holder as illustrated in Fig. 8.

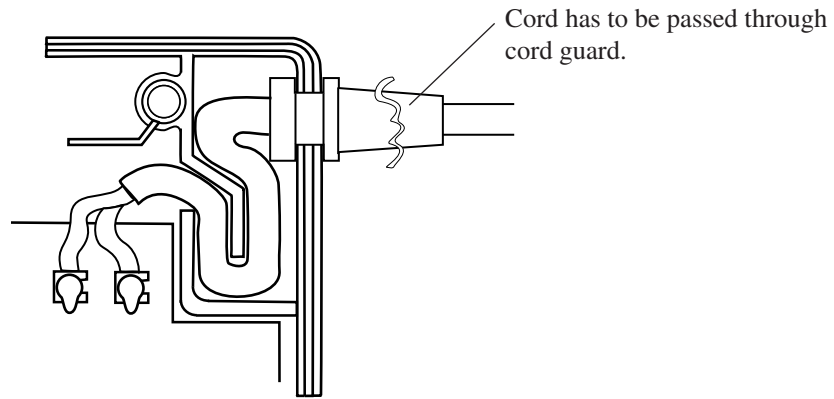

Fig. 8

<9> In case of damaged varistor or fuse, they can be repaired according to the following procedure without replacing the circuit board.

(1) How to find broken varistor

- a. In case that the surface of varistor (ref. to the following illustration) has broken or has become black, and fuse has been cut, the varistor has been damaged.
- b. Varistor can be damaged easily, if the charger is plugged in a double voltage of the rating one.
- c. It is considered that the varistor has been broken for other reasons, if the fuse is broken while the surface of varistor is not damaged. In this case charging circuit complete has to be replaced.

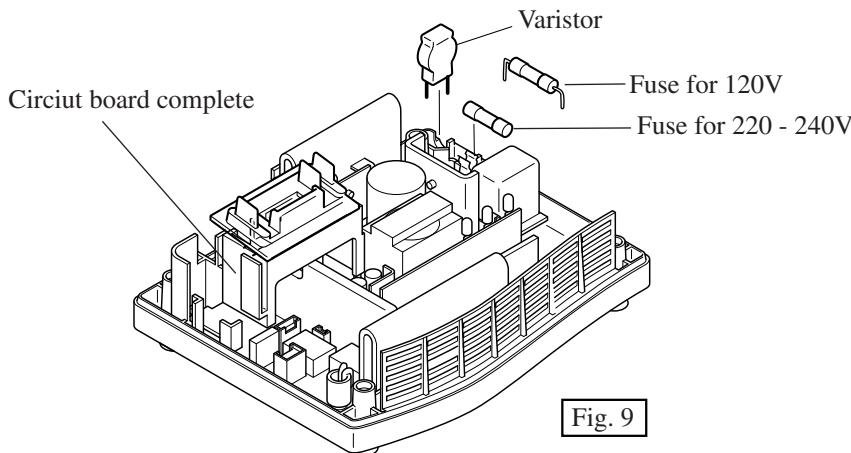

Fig. 9

(2) Removing broken varistor

- A. Cut the lead wire of varistor at the height of about 10mm from the surface of urethane resin.

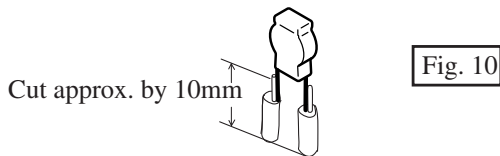

Fig. 10

- B. Take off lead wire's sheath by 2-3mm with nipper to expose the core.

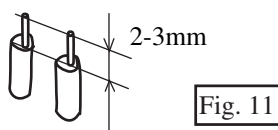

Fig. 11

(3) Assembling new Varistor (See Fig. 12)

- a. Cut new varistor's lead wires to 10 mm, and insert them about 5mm depth between the sheath and the core.
- b. Solder both lead wires, being so careful that they may not contact with each other.

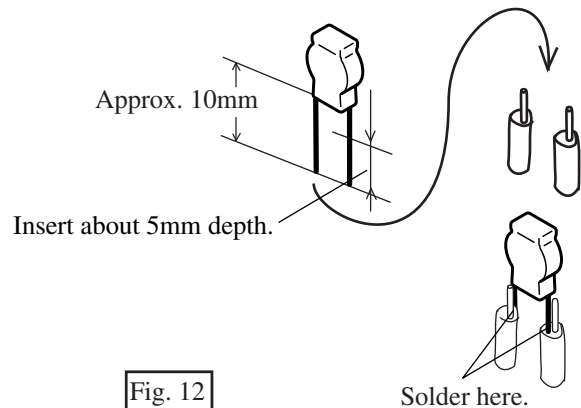

Fig. 12

(4) Replacing fuse for 220 - 240V (See Fig. 13)

1. Remove damaged fuse from the receptacle, and replace the damaged one with new fuse.

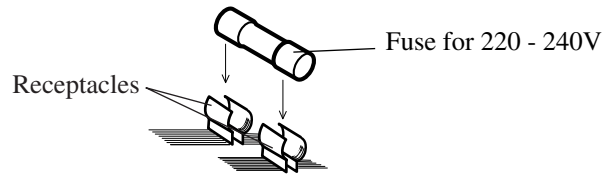

Fig. 13

(4A) Replacing fuse for 120 (See Fig. 13A.)

1. Remove damaged fuse from terminal with soldering iron.
  2. Connect the wire of fuse to the terminal by soldering.
- < Note > Be careful not to overheat the fuse with soldering iron. Otherwise the wire of fuse may be cut with the heat of soldering iron.

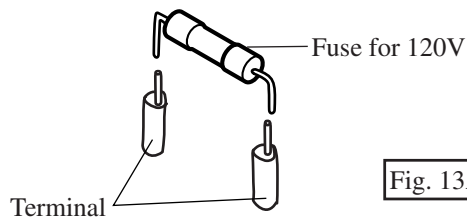

Fig. 13A

- <9> When finish of repair, fasten circuit board complete to charger case with 4 tapping screws 4 x 20.  
And, do not forget to attach 4 caps 13.

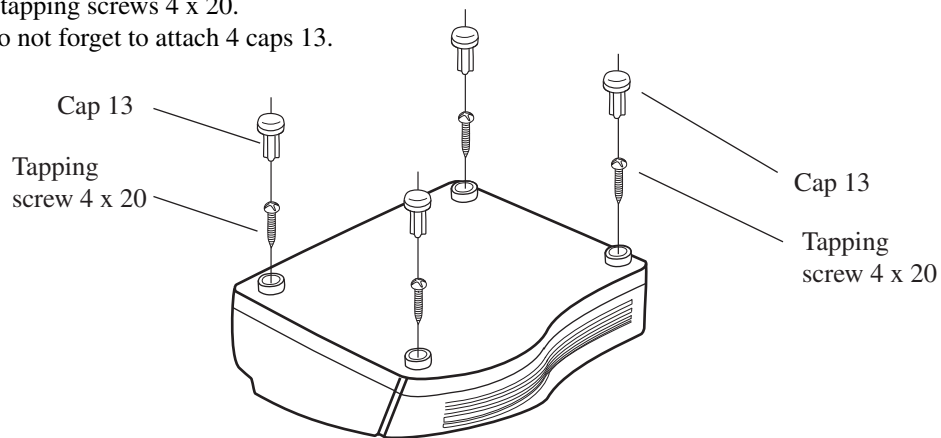
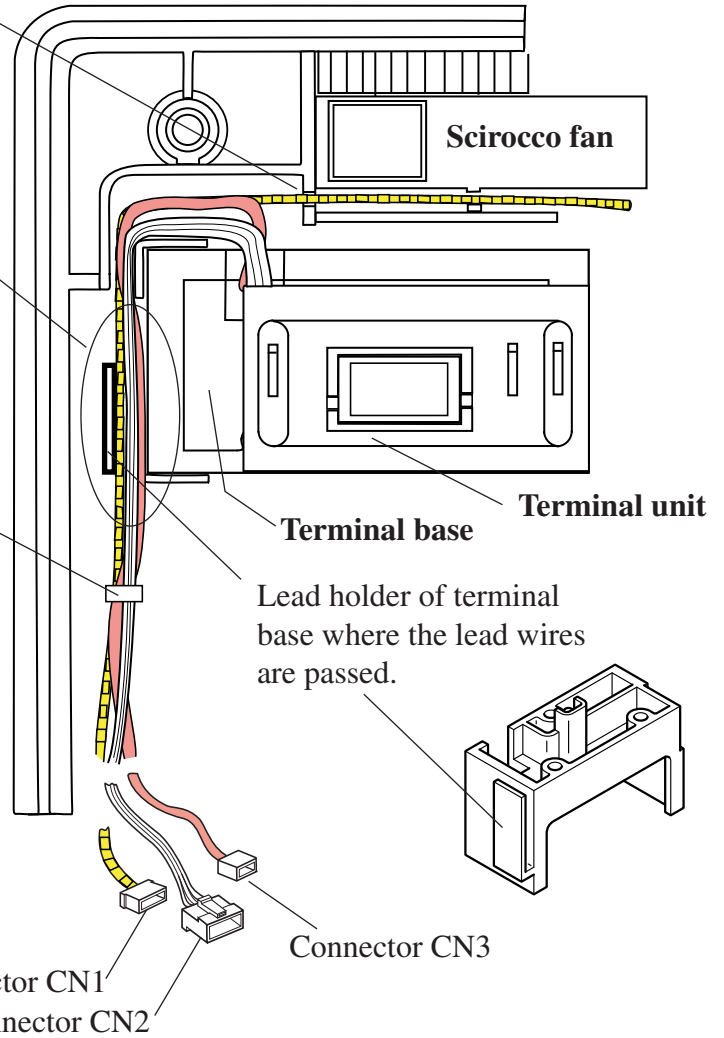

Fig. 14

Set lead wire of circa fan  
in the lead holder.

Pass lead wires of terminal unit and  
scirocco fan through the lead holder  
equipped on the terminal base.

Bind the lead wires  
with band.



Secure the connection of  
connector CN1, CN2 and CN3  
to circuit board complete.