

- Models No.** ▶ BTD042, BTD062, BTW072
- Description** ▶ Cordless Impact Drivers, Cordless Impact Wrench

## CONCEPTION AND MAIN APPLICATIONS

### BTD042, BTD062

These models are the advanced type of the existing model BTD040 and BTD060. They are equipped with Automatic Blow-Stop System, with which you can prevent an over-tightening. And the indication lamp featuring these models shows you the complete or incomplete fastening of bolts or screws.

### BTW072

This model is the 9.5mm(3/8") version of the existing model BTW062. Of course, it is equipped with Automatic Blow-Stop System and indication lamp showing complete and incomplete fastening like as BTD042 and BTD062.

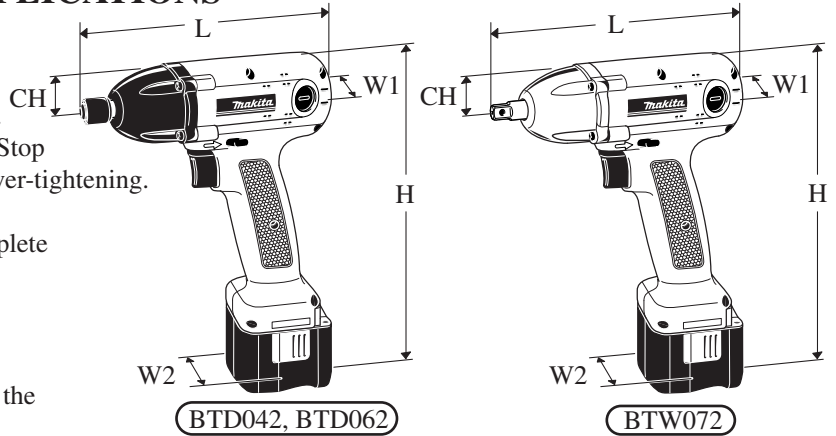

Dimensions : mm ( " )

|                    | TD042Z<br>TD062Z | TW072Z      |
|--------------------|------------------|-------------|
| Width 1 (W1)       | 55 (2-3/16)      |             |
| Width 2 (W2)       | 66 (2-5/8)       |             |
| Center Height (CH) | 25 (1)           |             |
| Height (H)         | 236 (9-5/16)     |             |
| Length (L)         | 164 (6-7/16)     | 166 (6-1/2) |

Note: Width 1 = Width of motor section  
Width 2 = Width of battery

## ► Specification

| Model No.                                       | BTD042                               | BTD062                              | BTW072                              |
|---|--------------------------------------|-------------------------------------|-------------------------------------|
| <b>Voltage (V)</b>                              | 9.6                                  | 9.6                                 | 9.6                                 |
| <b>No load speed (min.<sub>1</sub>=rpm)</b>     | 0 - 2,500                            | 0 - 2,500                           | 0 - 2,500                           |
| <b>Impact per minute (min.<sub>1</sub>=bpm)</b> | 0 - 3,500                            | 0 - 3,000                           | 0 - 3,000                           |
| <b>Driving shank : mm ( " )</b>                 | 6.35 (1/4) Hex                       | 6.35 (1/4) Hex                      | 9.5 (3/8) square                    |
| <b>Capacities</b>                               | <b>Machine screw</b>                 | M4 - M8<br>(5/32" - 5/16")          | M4 - M8<br>(5/32" - 5/16")          |
|   | <b>Standard bolt</b>                 | M5 - M10<br>(3/16" - 3/8")          | M5 - M12<br>(3/16" - 1/2")          |
|   | <b>High Tensile bolt</b>             | M5 - M8<br>(3/16" - 5/16")          | M5 - M10<br>(3/16" - 3/8")          |
| <b>Max. fastening torque</b>                    | 40N.m<br>(408Kgf.cm)<br>( 354in.lbs) | 65N.m<br>(663Kgf.cm)<br>(575in.lbs) | 65N.m<br>(663Kgf.cm)<br>(575in.lbs) |
| <b>Electric brake</b>                           | Yes                                  | Yes                                 | Yes                                 |
| <b>Reverse switch</b>                           | Yes                                  | Yes                                 | Yes                                 |
| <b>* Net weight: kg (lbs)</b>                   | 1.06 (2.4)                           | 1.09 (2.5)                          | 1.09 (2.5)                          |

\* Net weight : including battery B9017A

## ► Standard equipment

Battery B9017A ..... 1 pc.

< Note > The standard equipment for the tool shown may differ from country to country.

## ► Optional accessories

- \* Battery B9017A for Mod.BTD042, BTD062 and BTW072
- \* Protector for Mod.BTD042, BTD062 and BTW072
- \* Fast charger DC14SA for Mod.BTD042, BTD062 and BTW072
- \* Refresh adaptor Model ADP02 for Mod.BTD042, BTD062 and BTW072

## ► Repair

### <1> Disassembling housing R and L

Remove hammer case from housing by taking off 4 pan head screws M4x20, and disassemble housing R and L as illustrated in Fig. 1.

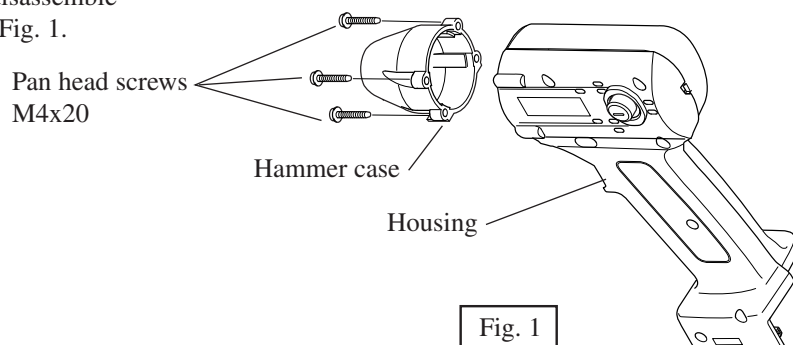

### <2> Disassembling bit holder section (anvil section)

Take off ring spring 10 from the groove on anvil. Then flat washer 11, compression spring 13 and sleeve can be removed from anvil by pulling them in the direction of the arrow in Fig.2. Anvil can be separated from hammer case after disassembling sleeve section.

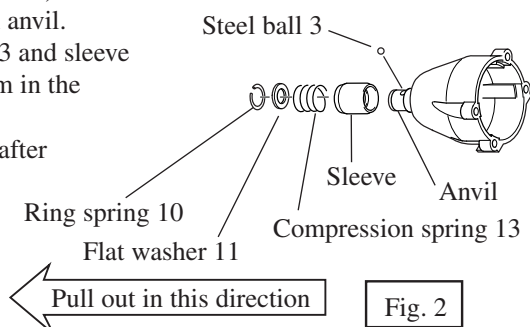

<3> Apply 0.5g of MAKITA grease N No.2 on the cylindric part of anvil, when inserting it into hammer case.

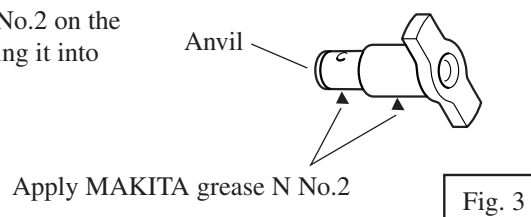

< 4 > Removing hammer

(1) Press down hammer with 1R045: Large gear extractor by turning the handle.

(2) Adjust the opening for steel ball inserting to the cam groove top of spindle.

(3A) Take 2 off steel balls 5.6 from spindle. (Mod.BTD062, BTW072)

(3B) Take 2 off steel balls 4.8 from spindle. (Mod.BTD042)

< Note > 29 pcs. of steel balls 3 are installed in hammer.  
Check the quantity when assembling.

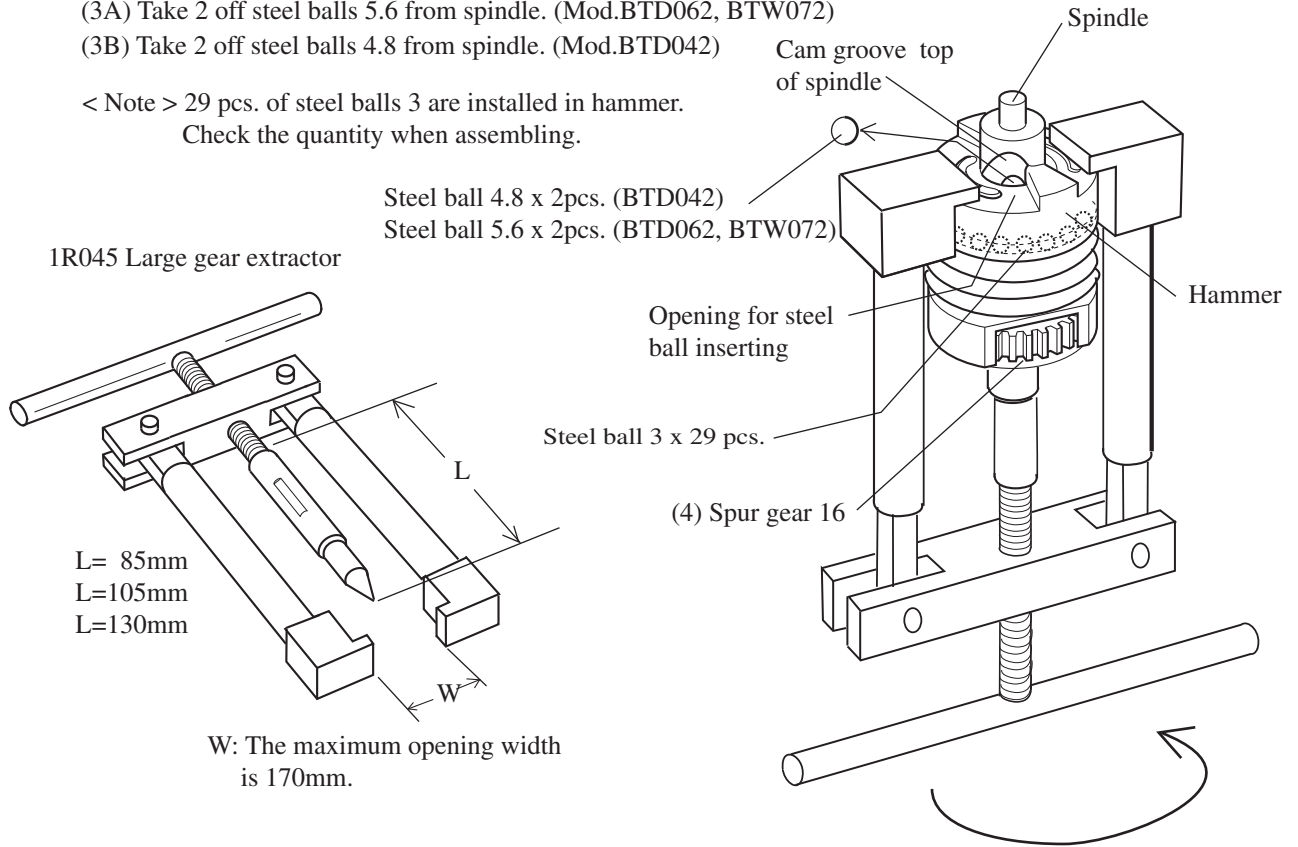

Fig. 4

(4) Apply MAKITA grease N No.2 to the position No. 1, 2, 3 and 4, when assembling.

(3A) Steel ball 5.6 x 2 (BTD062, BTW072)

(3B) Steel ball 4.8 x 2 (BTD042)

(2) Steel ball 3 x 29 pcs.

(1) Spindle : 0.5g

(2) Steel ball 3 : 0.5g

(3A) Steel ball 5.6 (BTD062, BTW072) : 0.5g

(3B) Steel ball 4.8 (BTD042) : 0.5g

(4) Spur gear 16 : 2.0g

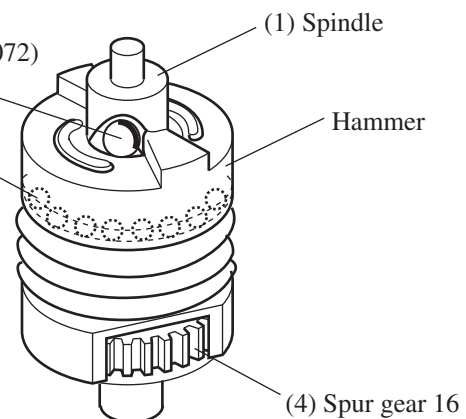
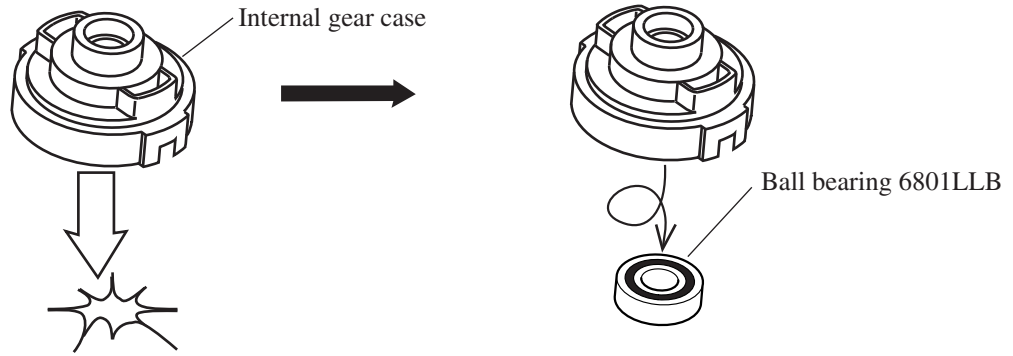

Fig. 5

< 5 > Removing ball bearing 6801LLB



Give a shock by knocking internal gear case on the table.

Ball bearing 6801LLB can be removed from internal gear case by the shock.

Fig. 6

< 6 > Fastening FET spacer with tapping screw ST 3x8

When assembling FET spacer, the fastening torque of tapping screw ST 3x8 is approx. 1.1 Nm - 1.5 Nm (11Kgf.cm - 15 Kgf.cm).

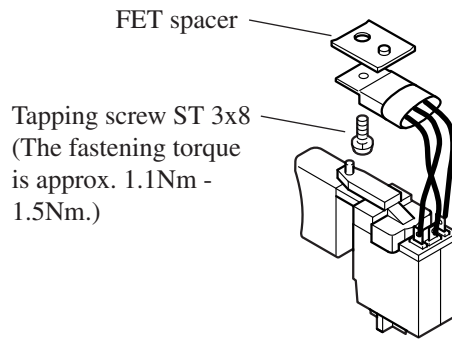

Fig. 7

< 7 > Hammer case has to be fastened diagonally as illustrated in in Fig.8.

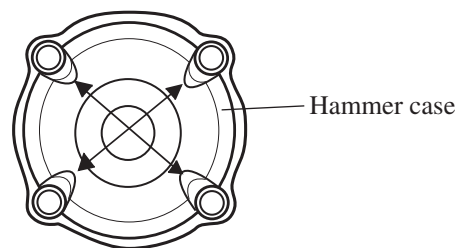
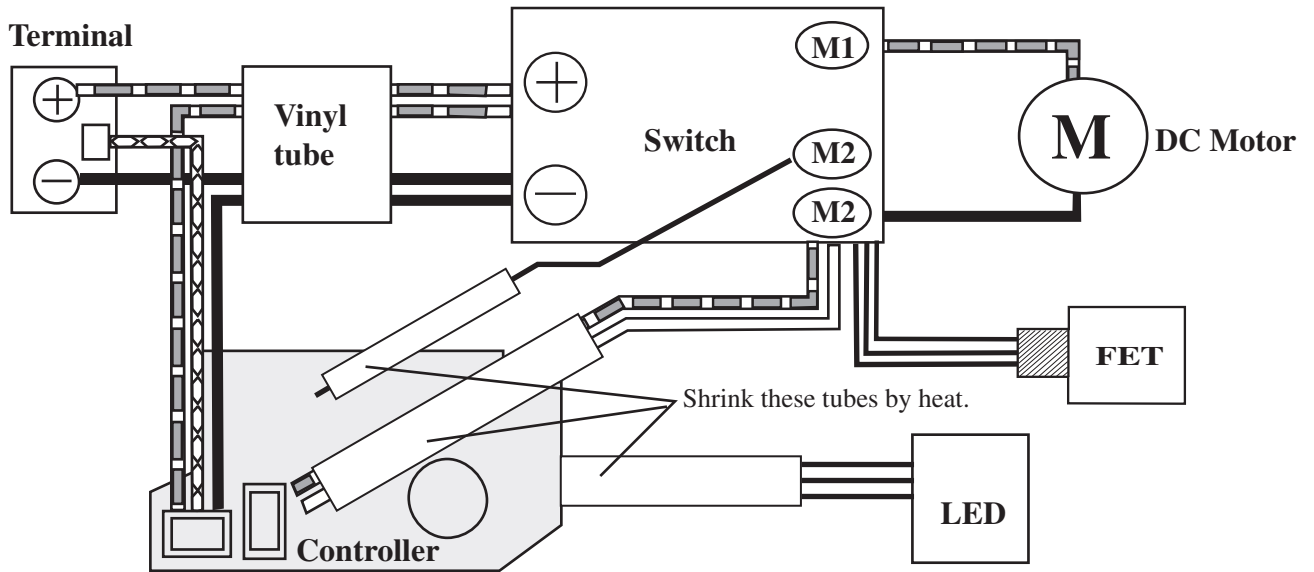

Fig.8

## ▶ Circuit diagram

| Color index of lead wires |  |
|---------------------------|--|
| Black                     |  |
| Red                       |  |
| White                     |  |
| Yellow                    |  |



## ▶ Wiring diagram

