

Models No. ▶ BJR240

Description ▶ Cordless Recipro Saw

CONCEPTION AND MAIN APPLICATIONS

The above model has been developed to be added to MAKSTAR series models which are featuring New Charging System.

Other features and benefits are

- * The fastest cutting speed among the cordless reciprocating saws
- * Incredible low vibration with counterbalancing system in its gear unit.
- * Tool-less features for easy and rapid changing reciprocating saw blade and for easy adjusting shoe

The variations of this model are listed below.

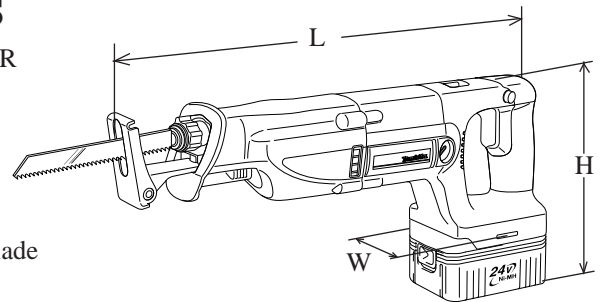

Model No.	Battery	Q'ty of Battery	Charger
BJR240SH	B2417 (1.7Ah)	1 pc.	DC24SA
BJR240SF	B2430 (3.0Ah)	1 pc.	DC24SA

Dimensions : mm (")		
Length (L)	469 (18-1/2)	
Height (H)	w /B2430	255 (10)
	w /B2417	230 (9)
Width (W)	88 (3-1/2)	

► Specification

Battery	Voltage : V	24
	Capacity : Ah	1.7 with Battery B2417 3.0 with Battery B2430
Length of Stroke		32 mm (1-1/4")
Strokes per Minute :spm.(min-1)	High	0 - 2,700
	Low	0 - 2,300
Cutting capacity: mm (")	Pipe	ø 90 (3-1/2)
	Wood	90 (3-1/2) in thickness
Electric brake		Yes
Speed change		Yes (Electric 2 speed)
Variable switch		Yes
Net Weight : Kg (lbs)	with B2430	4.9 (10.8)
	with B2417	4.4 (9.7)

► Standard equipment

- * Recipro saw blade No.21 for steel 1 pc.
- * Recipro saw blade No.22 for steel 1 pc.
- * Recipro saw blade No.23 for wood 1 pc.
- * Plastic carrying case 1 pc

< Note > The standard equipment for the tool shown may differ from country to country.

► Optional accessories

- * Various reciprocating saw blades
- * Battery B2417
- * Charger DC24SA
- * Battery B2430

< 1 > Lubrication

Apply MAKITA grease N No.1 to the following portions marked with black triangle to protect parts and machine from unusual abrasion. See Fig. 1.

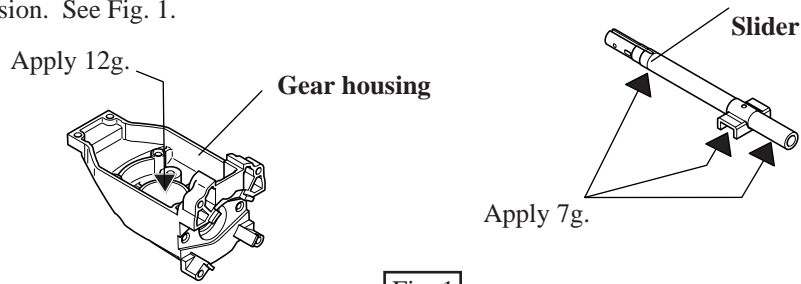

Fig. 1

< 2 > Sealing

Apply three bond 1215 to the following portion of gear housing cover which joins to gear housing, when assembling. See Fig. 2.

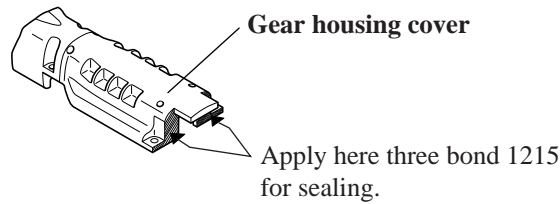
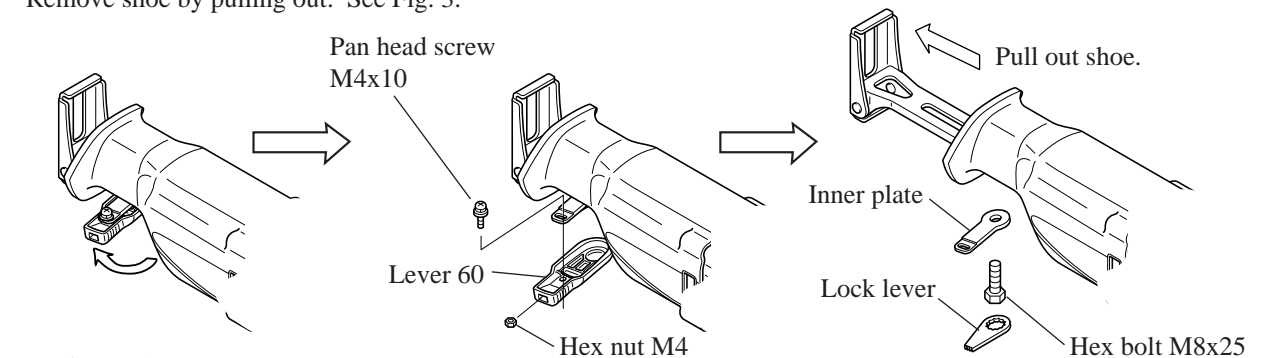

Fig. 2

< 3 > Disassembling and assembling

(1) Removing shoe

Turn lever 60 (adjusting lever for shoe), and take off pan head screw M4x10. Then, lever 60 can be removed. Take off hex bolt M8x25 (This hex bolt can be unscrewed by using lock lever as a wrench.), and inner plate. Remove shoe by pulling out. See Fig. 3.



Take off pan head screw M4x10.
<Note> Be careful, not to lose hex nut M4 in lever 60.

Fig. 3

(2) Disassembling blade clamp section

Remove shoe as mentioned above. Pull out the blade clamp section, if it stays near gear housing.

1. Take off retaining ring S-18 with No.1R291 "Snap ring plier".
2. Take off driving sleeve, shoulder pin 5, compression spring 6, pin 3, guide sleeve and driving sleeve guide from slider.

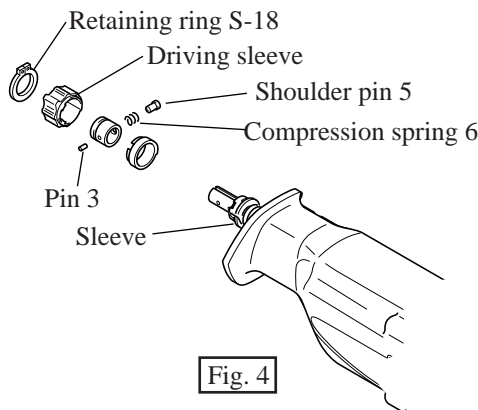

Fig. 4

- Sleeve is in the lock position. In order to free from lock position, pull sleeve toward the blade installing side.
(When the sleeve is free from lock, pin 3 (long) is at the position illustrated in Fig. 5.)

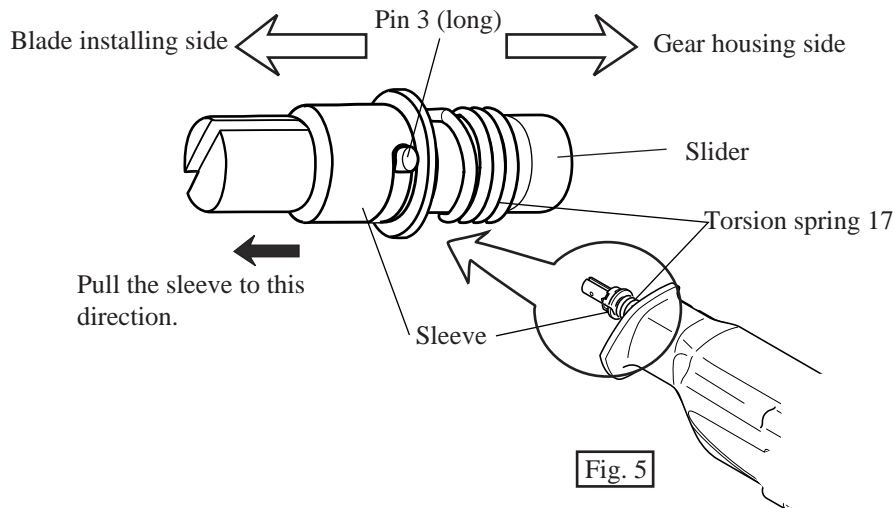

Fig. 5

- Holding the top of slider with your finger, remove sleeve by pushing pin 3 (long) with a small sticker through slider as illustrated in Fig. 6.
< Note > When removing sleeve, always hold the top of slider with your finger as illustrated in Fig. 6. Otherwise, push plate and compression spring 2 can spring out from slider as illustrated in Fig. 6A, and they will get lost.
After removing sleeve, take off push plate, compression spring 2 and torsion spring 17 from slider as illustrated in Fig. 6B.

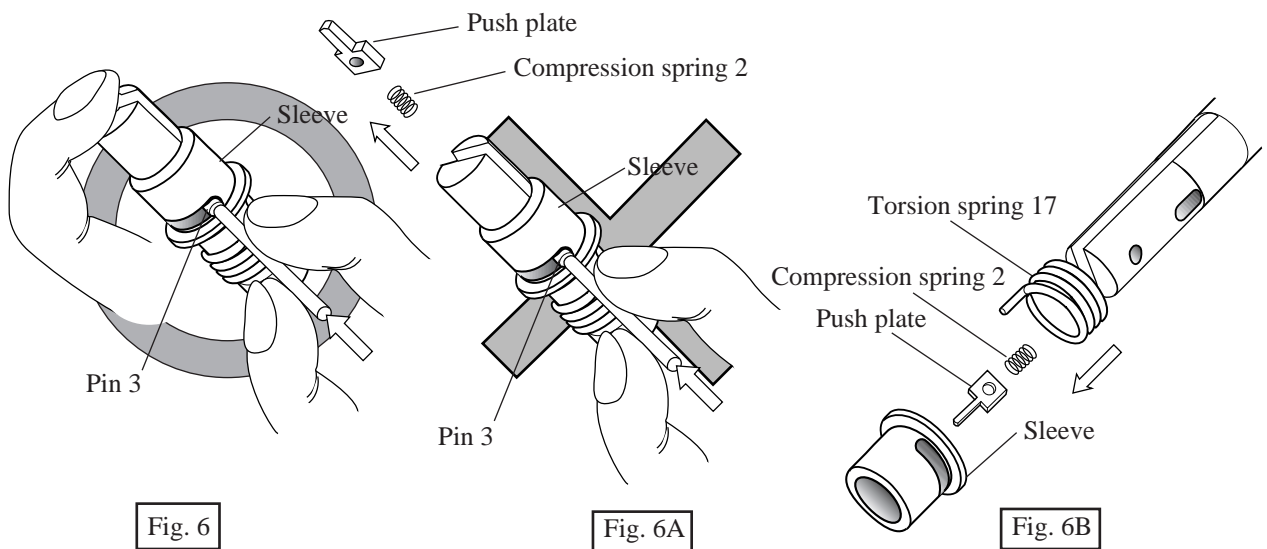

Fig. 6

Fig. 6A

Fig. 6B

(3) Assembling blade clamp section

- Assemble torsion spring 17 to slider. And then, set compression spring 2 into slider.
<Note> Pay attention to the position of the tail of torsion spring 17. It has to come to the right side in the view from the side of shoe adjusting bolt M8x25, as illustrated in Fig. 7.

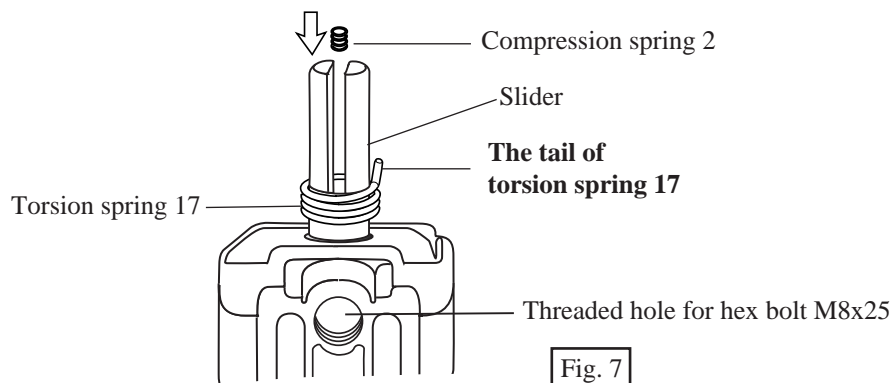
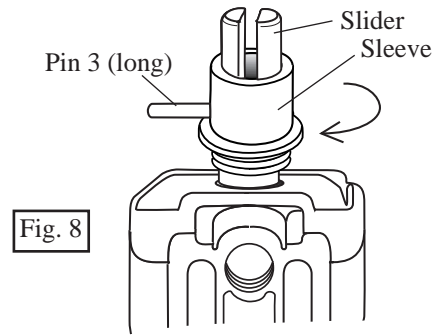
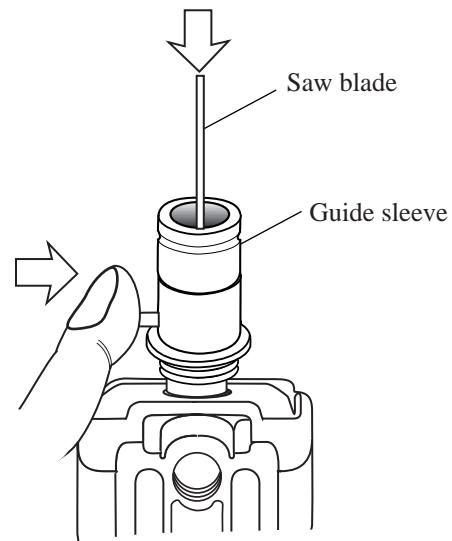
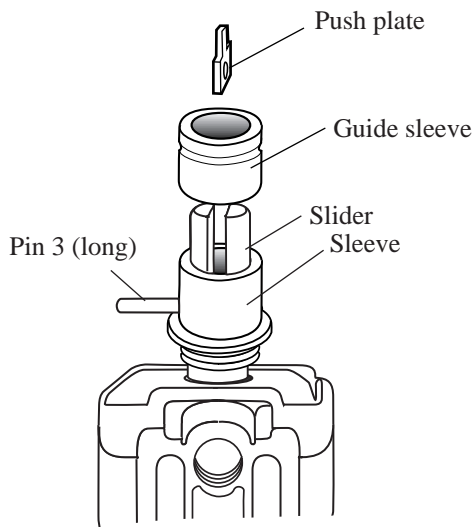

Fig. 7

2. Set sleeve to slider and turn it clockwise.
Fit sleeve with pin 3 (long) to slider as illustrated in Fig. 8.
<Note> No need to fix sleeve by inserting pin 3 (long) through slider in this stage.



3. Set guide sleeve to slider and insert push plate into slider as illustrated in Fig. 9. Push the push plate in the vertical direction with saw blade, and pass pin 3 (long) through the hole of push plate as illustrated in Fig. 9A.



4. Remove guide sleeve and, push the driving sleeve toward the gear housing side turning it clockwise. Then sleeve can be brought to the locked position with pin 3 (long). See Fig. 10 and Fig. 10A.

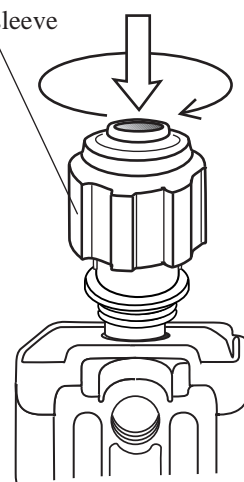
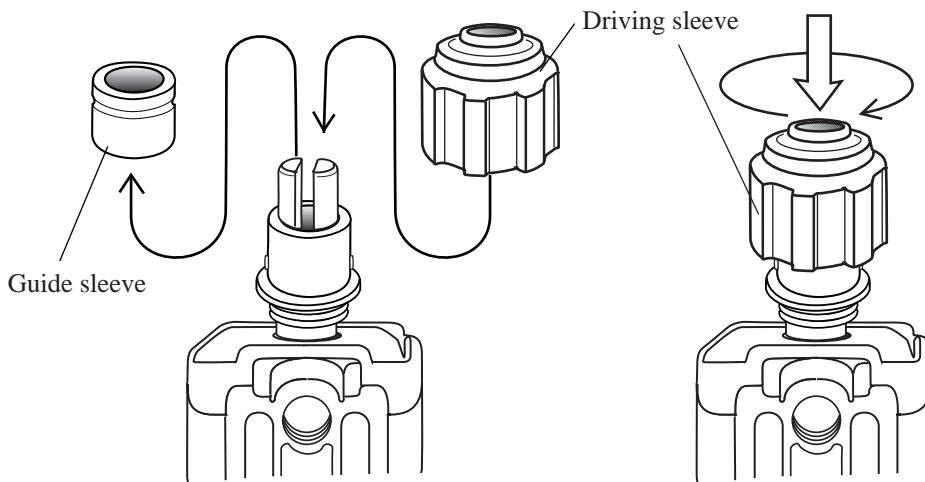

5. Remove driving sleeve, and assemble the following parts to slider. See Fig. 11.
 - (7) Driving sleeve guide,
 - (6) Guide sleeve
 - (1) Shoulder pin 5 (Apply a bit of MAKITA grease N.No.1 to shoulder pin 5, when assembling it.)
 - (2) Compression spring 6
 - (5) Pin 3 (short)

Aligning the convex portion of driving guide with the concave portions of sleeve and driving sleeve guide, assemble driving sleeve and fasten it with retaining ring S-18. See Fig. 11A.

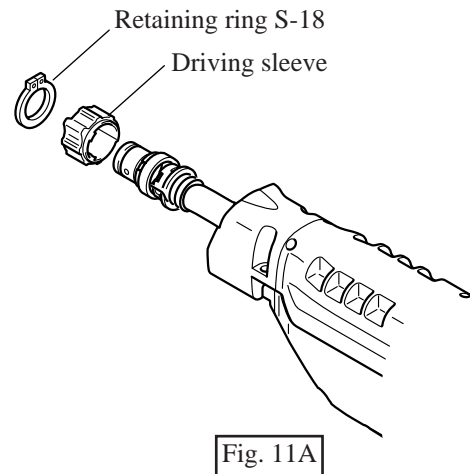
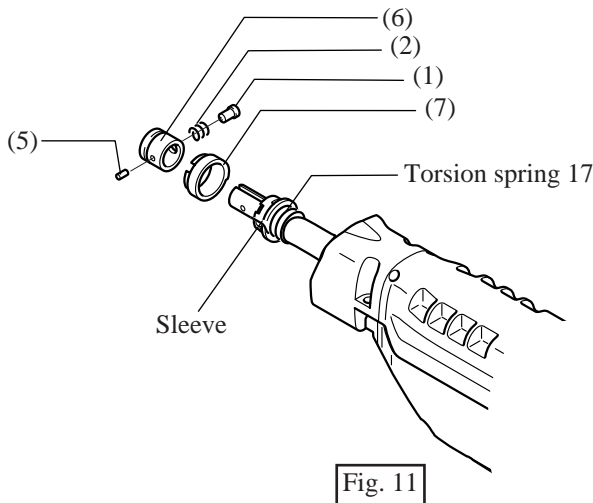

(3) Disassembling slider

1. Remove insulation cover, shoe and blade clamp section. Refer to (1) Removing shoe and (2) Disassembling blade clamp section.
2. Unscrew 4 pcs. of pan head screws M5x18, and separate gear housing cover from gear housing, as illustrated in Fig. 12.
3. Take off 2 pcs. of plates by unscrewing 4 pcs. of pan head screws M5x16. Remove plane bearing 14 of motor housing side, from slider. See Fig. 12A.

< Note > Use impact driver for loosening pan head screws M5x16 which are fastening plates, because it is difficult to loosen them with hand due to the adhesive on pan head screws M5x16.

4. Pushing slider to the motor housing side, remove it from gear housing cover. See Fig. 12A.

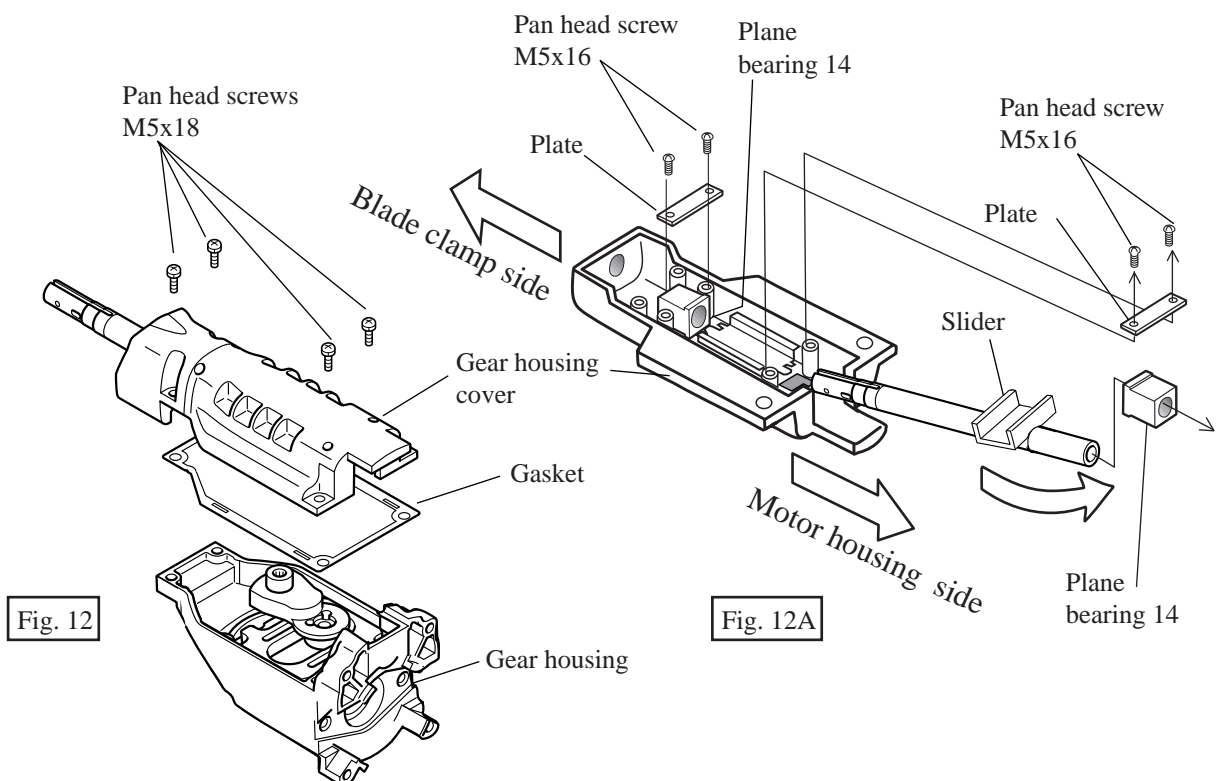

(4) Assembling slider

< Note > Pay attention to the following matters, before assembling slider section.

- a. Make sure that the following parts are already installed on gear housing cover.
 - * Slide plate See Fig. 13
 - * 2 pcs. of plates 12x16 (made of felt) on the places for plane bearings See Fig. 13.
- b. Apply machine oil #120 to plates 12x16. See Fig. 13.
- c. Apply a bit of MAKITA grease N.No.1 to the inside of dust seal 14 where the slider reciprocates.
- d. Apply 7g of MAKITA grease N No.1 to slider. See Fig. 13A.

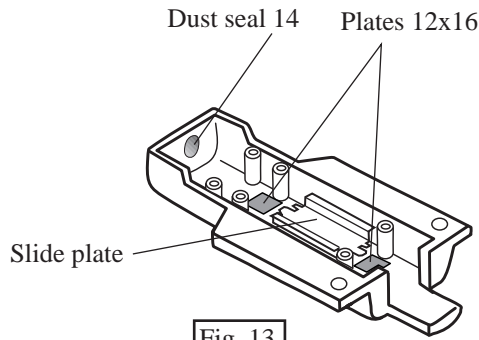

Fig. 13

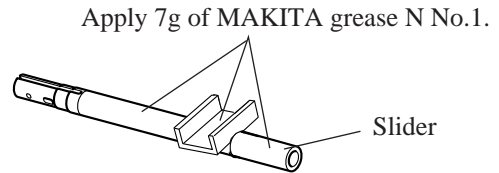

Fig. 13A

1. Pass slider through plane bearing 14 from the blade clamp side as illustrated in Fig.14. And then, pass the slider through dust seal in gear housing cover. Assemble plane bearing 14 to the motor housing side of slider as illustrated in Fig. 14A. And fit plane bearings 14 on plates 12 x16 (made of felt) respectively.

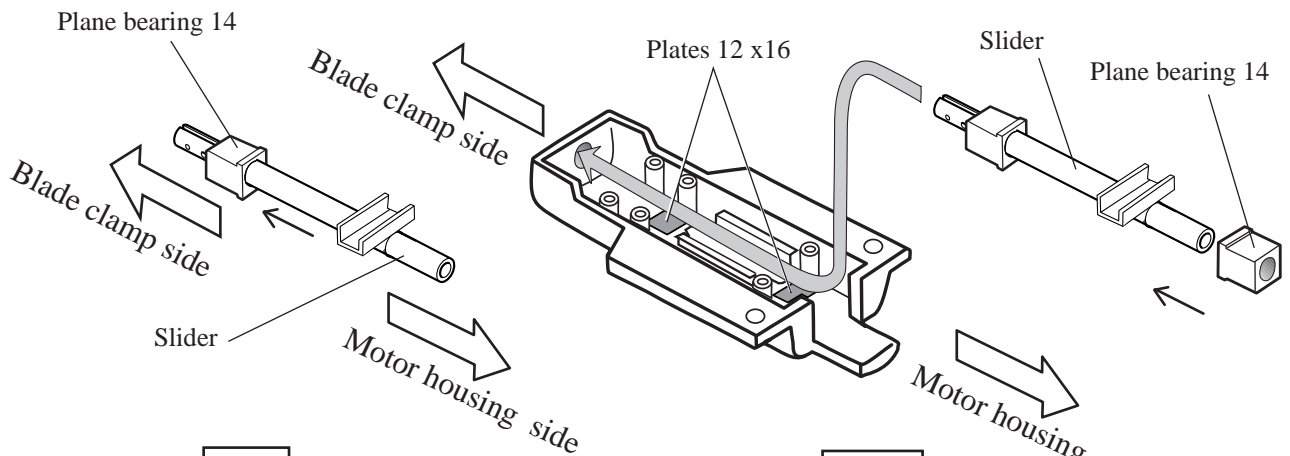

Fig.14

Fig.14A

< Note >

Pay attention to the assembling direction of plane bearings 14, when they are assembled to slider. See Fig. 14B

The convex portions of plane bearings have to face to the center of slider, each other.

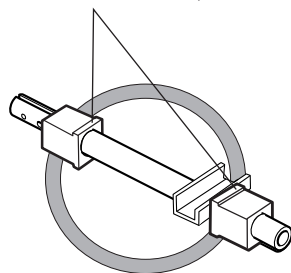

The convex portions of plane bearings do not face to the center of slider.

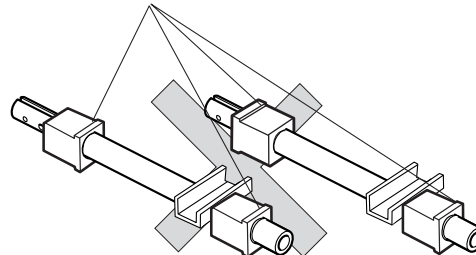

Fig.14B

2. Fix plane bearings 14 and plates with 4 pcs. of pan head screws M5x16 as illustrated in Fig.15.

< Note > Do not fasten the parts with the used pan head screws M5x16. Always use fresh adhesive ones.

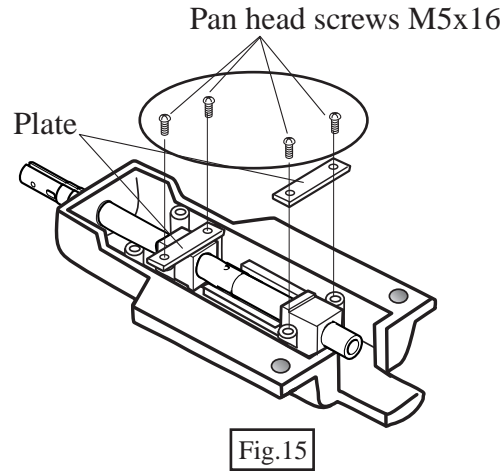

Fig.15

(5) Assembling dust seal to gear housing cover
 When assembling dust seal 14, apply the taper side of No.1R030 "Bearing Setting Pipe" on dust seal 14. Assemble dust seal 14 by pressing the above bearing setting pipe with arbor press. See Fig. 16.

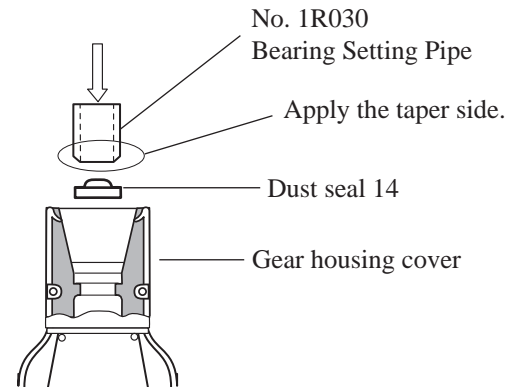

Fig.16

(6) Disassembling gear section

1. Remove insulation cover and shoe.
2. Unscrew 4 pcs. of pan head screws M5x18, and separate gear housing cover from gear housing, as illustrated in Fig. 12 at page 5.
3. Lock crank shaft by inserting No.1R247 "Round Bar for Arbor" into the elliptic hole of counter weight. Unscrew hex socket head bolt M6x18 to which adhesive is applied in advance, with hex wrench, or impact driver See Fig. 17.
4. Remove crank shaft, ring 21, counter weight and plate.

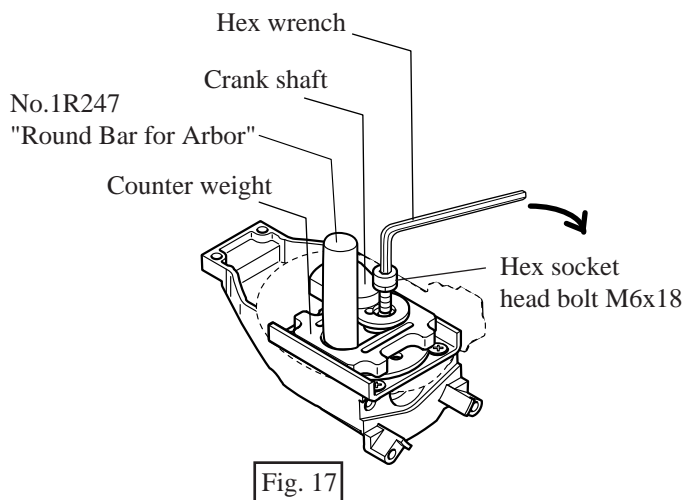

Fig. 17

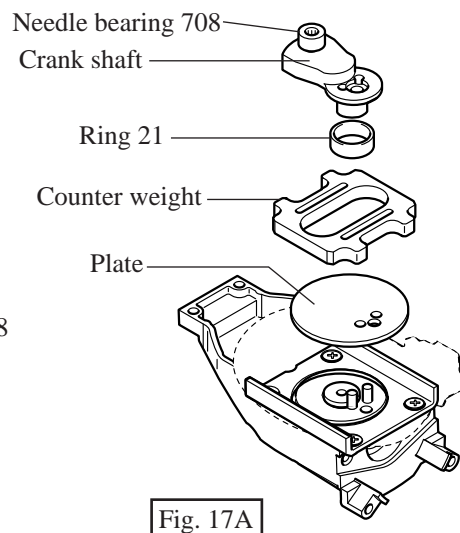

Fig. 17A

► Repair

5. Remove guide plate by unscrewing 4 pcs. of countersunk head screws M5x12. See Fig. 17B.
 < Note > Use impact driver for loosening countersunk head screws M5x12, because it is difficult to loosen them with hand due to the adhesive on countersunk head screws M5x12.
6. Bearing retainer 18 and gear section (ball bearings 6001LLB and 6202LLB, gear shaft, ring 15, gear complete and hex socket head bolt M10x18) are fastened with 4 pcs. of hex socket head bolts M5x10 from the shoe adjusting lever side of gear housing. Unscrew these hex socket head bolts M5x10. See Fig. 17B.
 < Note > Use impact driver for loosening hex socket head bolts M5x10, because it is difficult to loosen them with hand due to the adhesive on hex socket head bolts M5x10.
7. Slightly hitting the edge of gear housing with plastic hammer, remove gear complete as illustrated in Fig. 17C.

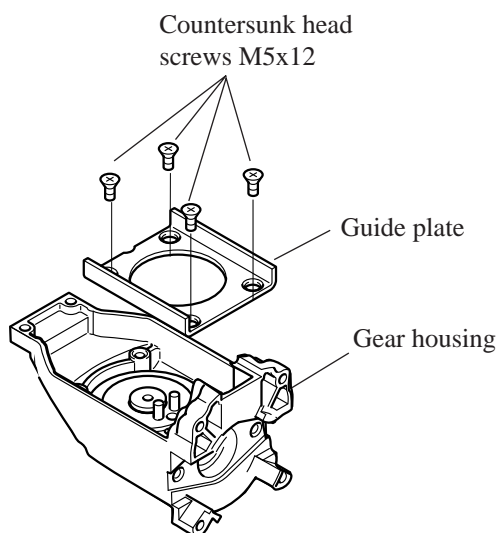

Fig. 17B

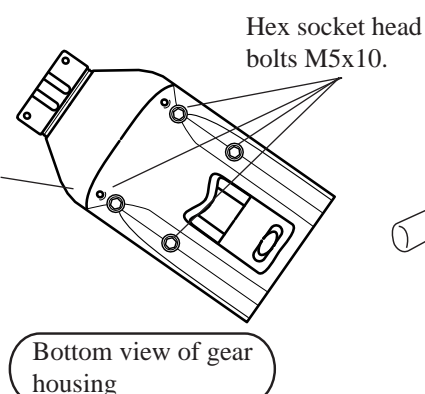

Fig. 17B

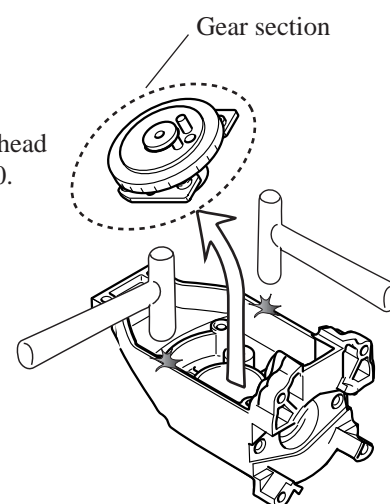

Fig. 17C

8. Holding the flat portion of gear shaft with a wrench, unscrew hex socket head bolt M10x18. Then, gear complete can be removed from gear shaft. See Fig. 17C.
 < Note > Use impact driver for loosening hex socket head bolts M18x18, because it is difficult to loosen them with hand due to the adhesive on hex socket head bolts M10x18.

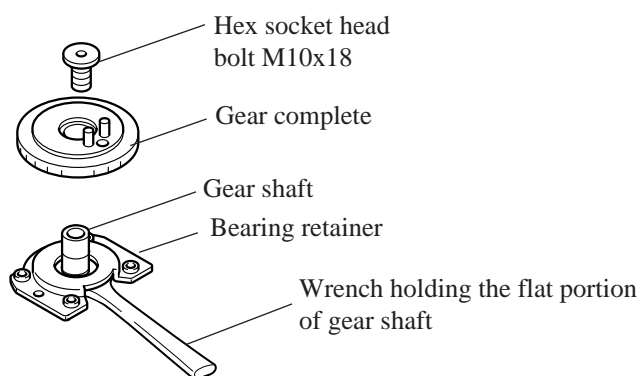
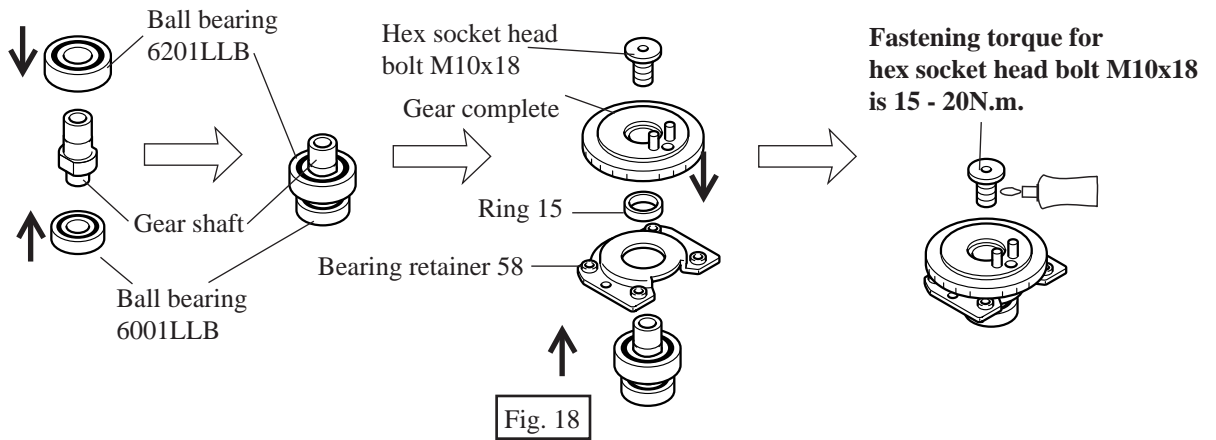

Fig. 17C

(7) Assembling gear section

1. Assemble gear section as illustrated in Fig. 18.

< Note > Do not fasten the parts with the used adhesive hex socket bolt M10x18. Always use the fresh adhesive one.



2. Assemble the gear section to gear housing with aligning the concave portion of bearing retainer 58 with the edge of bearing setting hole of gear housing. See Fig. 19.

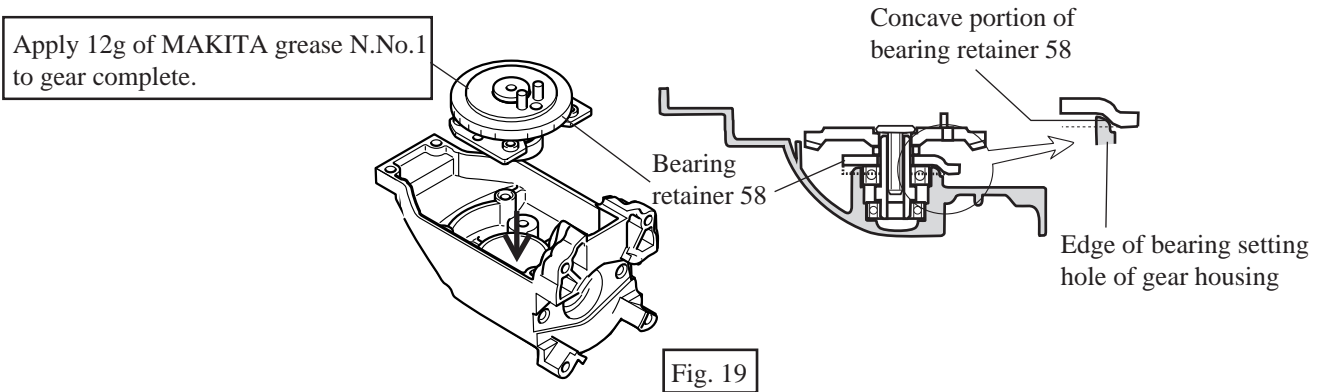

3. Assemble the gear section to gear housing with aligning the concave portion of bearing retainer 58 with the edge of bearing setting hole of gear housing. See Fig. 19A.

< Note > Do not fasten the parts with the used adhesive countersunk head screws M5x12 and hex socket head bolt M6x18. Always use fresh adhesive ones.

Apply a bit of MAKITA grease N.No.1 to crank shaft, counter weight and plate

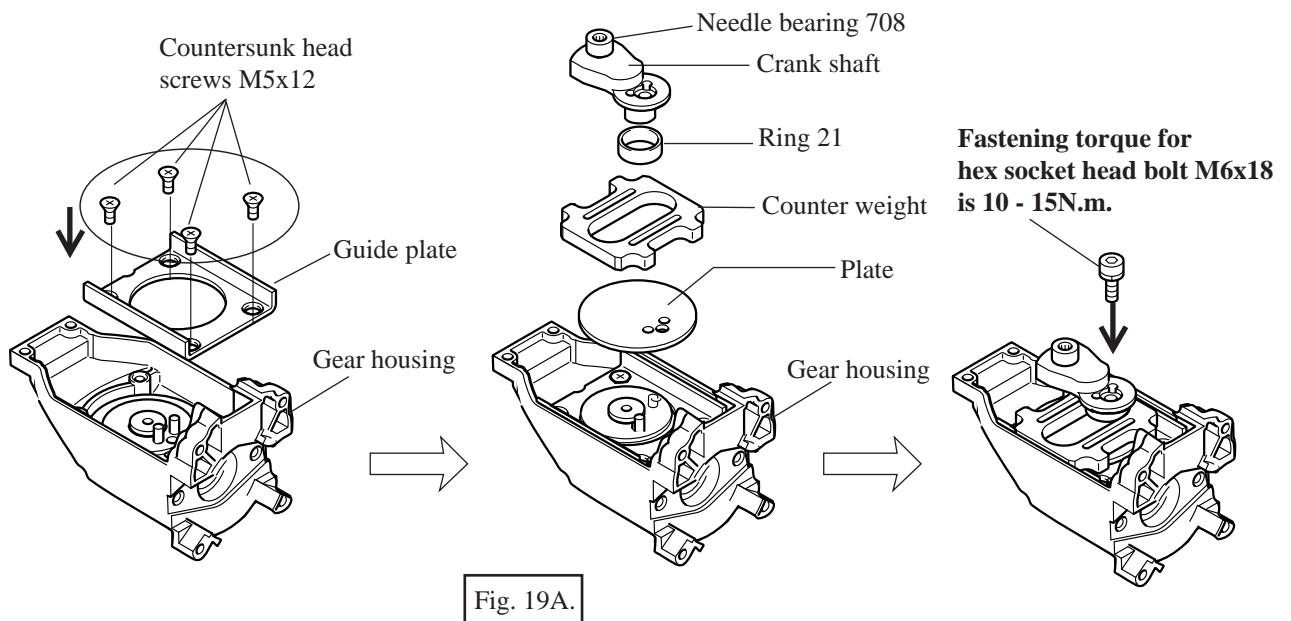

(8) Disassembling armature

1. After removing shoe and insulation cover, remove brush holder caps and carbon brushes. And separate the gear housing section from motor housing by unscrewing 4 pcs. of tapping screws M5x30. See Fig. 20.

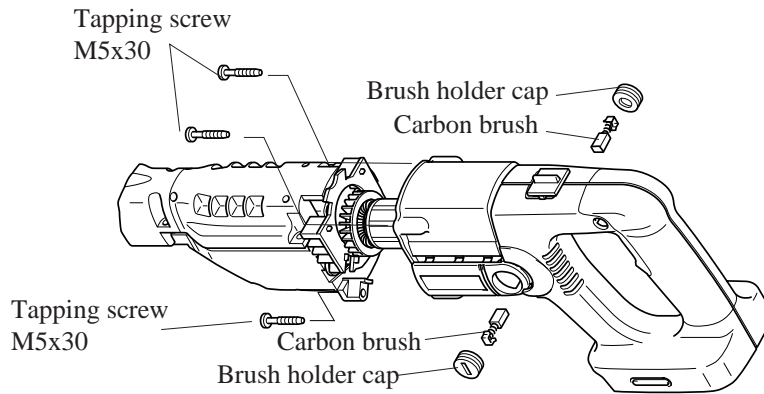

Fig. 20

2. Remove baffle plate, and unscrew 2 pcs. of countersunk head screws M5x12, then armature can be removed together with bearing retainer 58, from gear housing section. See Fig. 20A.

< Note > Countersunk head screws M5x12 are the adhesive screws. It is recommended to unscrew with an impact driver.

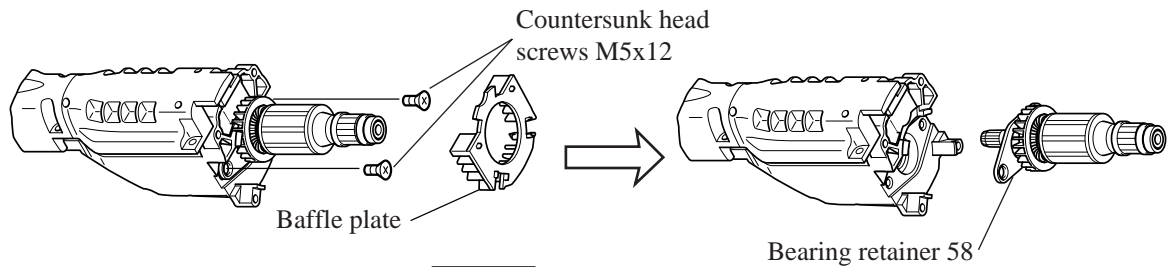

Fig. 20A

3. After taking off the stop ring E-10 of armature's gear side, remove ball bearing 6001DDW with No.1R269 "Bearing Extractor". Then, armature can be separated from bearing retainer 58.

Holding the armature body with plier, remove ball bearing 627DDW with No.1R269 "Bearing Extractor". See Fig. 20B.

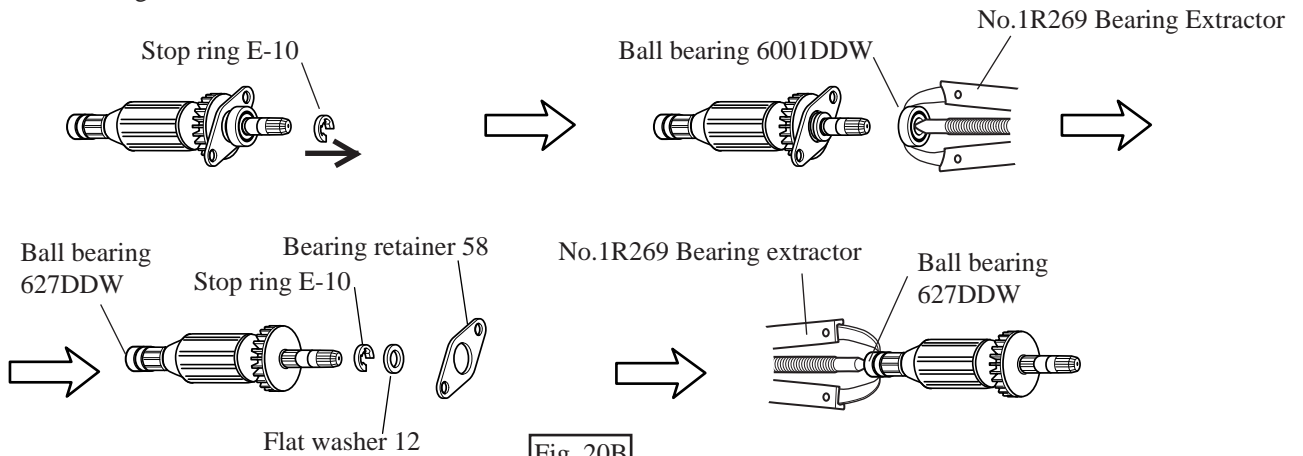

Fig. 20B

(9) Assembling armature

1. Take the reverse steps of the above Figs.

< Note > Do not fasten bearing retainer 58 with the used adhesive countersunk head screws M5x12 in the step of Fig. 20A. Always use fresh adhesive countersunk head screws.

< Note > Be careful, not to be pinched your fingers between motor housing and gear housing section in the step of Fig. 20, because armature is dragged strongly by magnetic force of yoke.

► Repair

(10) Disassembling handle section

1. Unscrewing 4 pcs. of tapping screws M4x30 and 2 pcs. of tapping screws M4x20, remove handle R from handle L. So, the inner parts (for instance switch, terminal, etc.) can be removed. See Fig. 21.

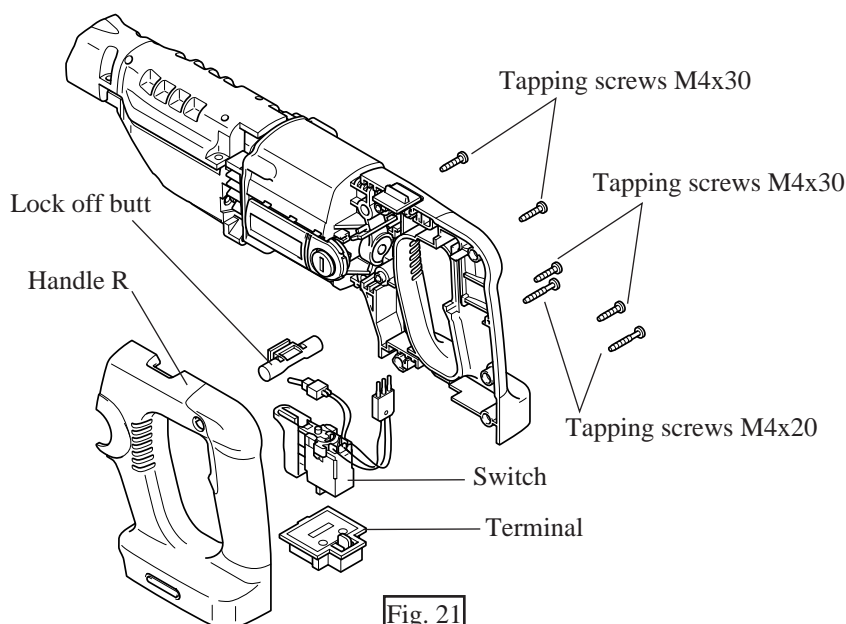

Fig. 21

2. Remove bumper, carbon brush and brush holder cap from motor housing. Then, brush holder can be removed. See Fig. 22.

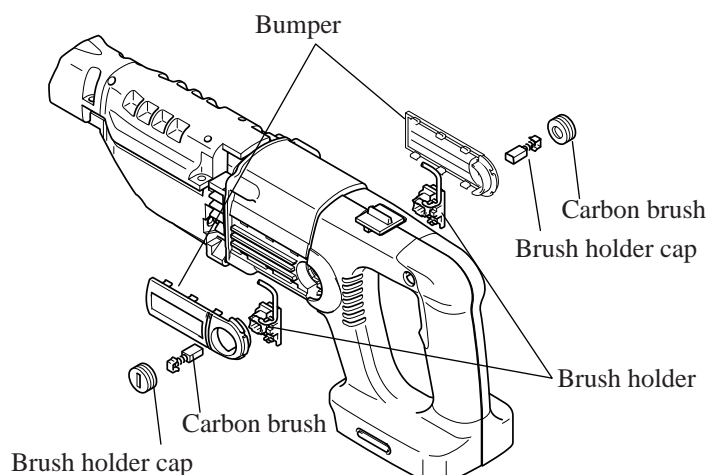

Fig. 22

(11) Note in assembling handle section

Insert leaf spring for High-Low speed change lever into the groove of handle L and insert its another end into the groove of handle R firmly. See Fig. 23.

After assembling, check whether speed change lever can be locked by leaf spring on "L" and "H" side respectively, when speed change lever is slid.

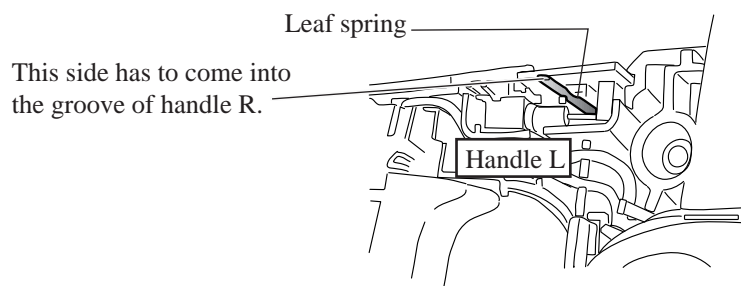
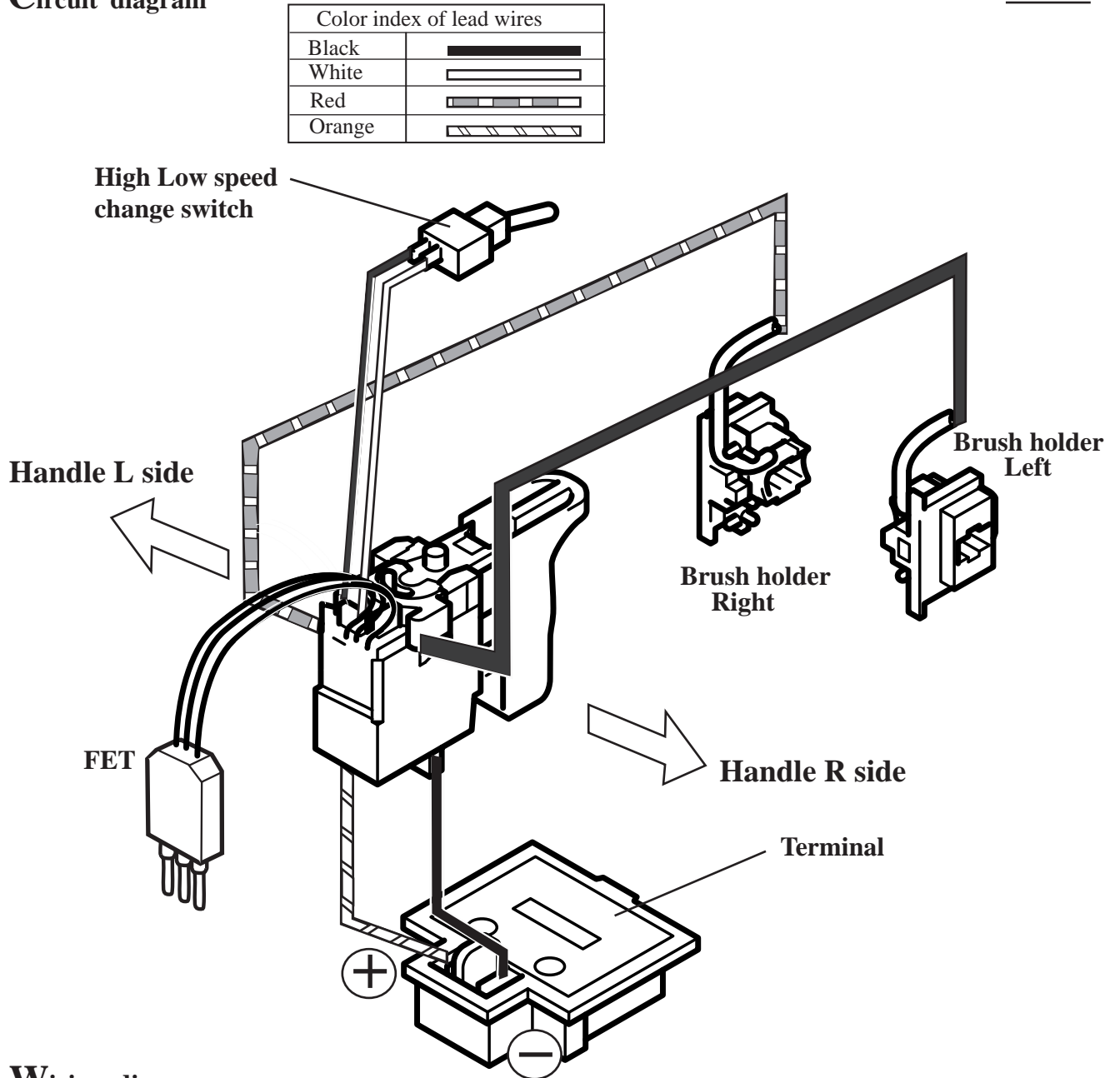

Fig. 23

▶ **Circuit diagram**



▶ **Wiring diagram**

(Rear side of motor housing)

Pass lead wires of brush holders through rib holding with lead holder A and B.

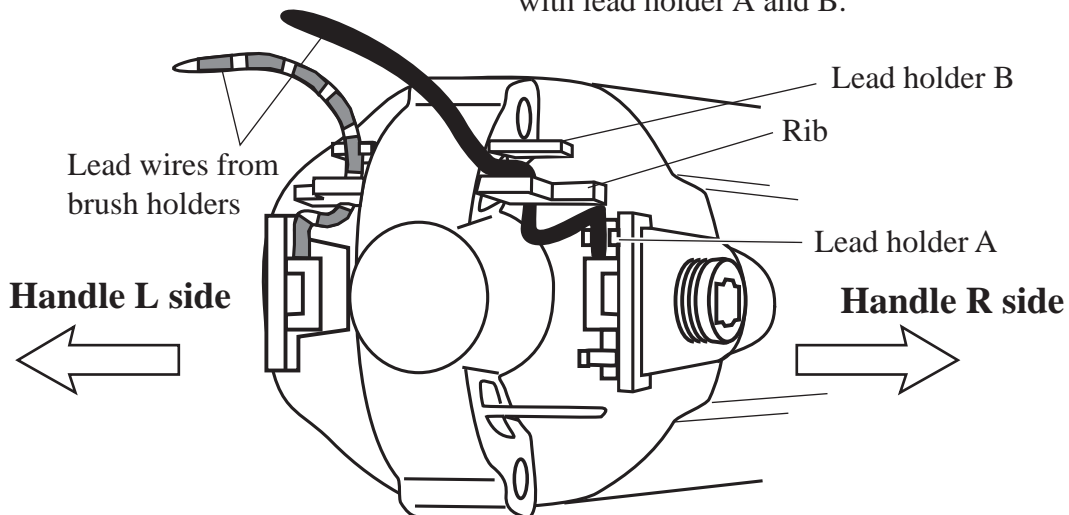

(In the handle R section)

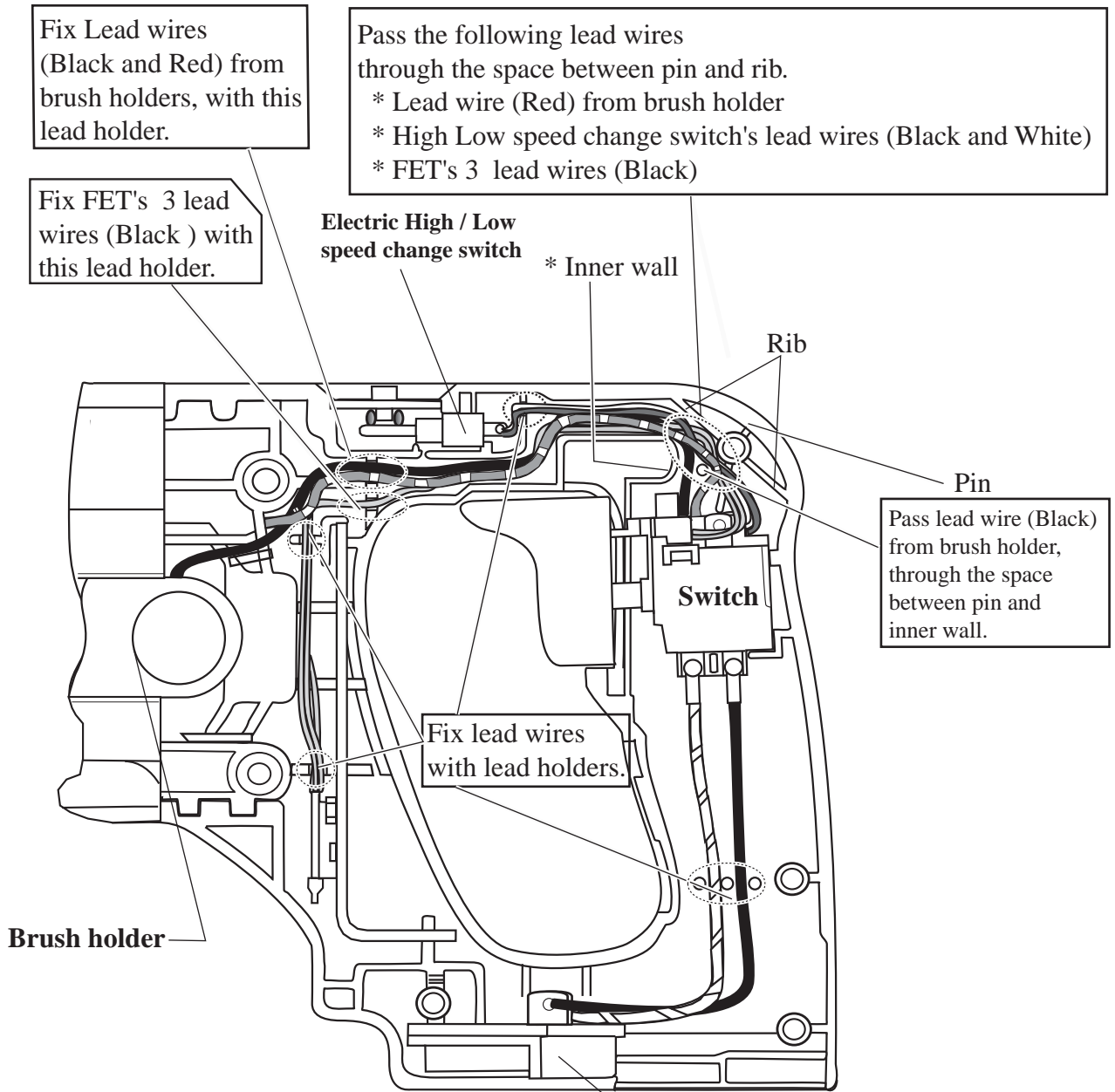

Wiring at the * Inner wall portion

Terminal

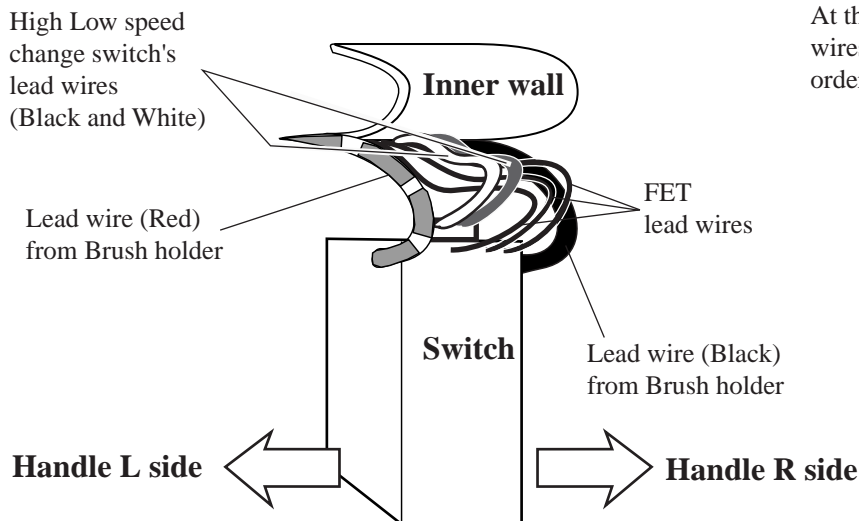

At the inner wall portion, set the lead wires onto handle R in the following order.

1. Lead wire (Black) from brush holder
2. FET lead wires
3. High Low speed change switch's lead wires (Black and White)
4. Lead wire (Red) from brush holder