

# TECHNICAL INFORMATION



PRODUCT

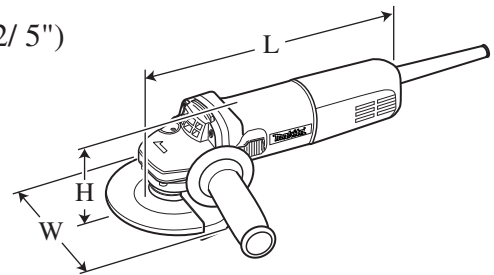
P 1 / 8

**Models No.** ▶ 9553NB, 9554NB, 9555NB

**Description** ▶ Angle Grinders 100/115/125mm (4/ 4-1/2/ 5")

## CONCEPT AND MAIN APPLICATIONS

The 9553NB series models have been developed as upgraded sister tools of the current 9523NB series models. Features more powerful motor for higher performance efficiency, yet still having the same compact and lightweight body for comfortable handling as the current series models.



Dimensions: mm (")			
Model No.	<b>9553NB</b>	<b>9554NB</b>	<b>9555NB</b>
Length (L)	258 (10-1/8)		
Width (W)	118 (4-5/8)	129 (5-1/8)	139 (5-1/2)
Height (H)	97 (3-13/16)	106 (4-3/16)	

## ► Specification

Voltage (V)	Current (A)	Cycle (Hz)	Continuous Rating (W)		Max. Output(W)
			Input	Output	
110	6.8	50 / 60	710	420	800
120	6.0	50 / 60	710	420	800
220	3.4	50 / 60	710	420	800
230	3.2	50 / 60	710	420	800
240	3.1	50 / 60	710	420	800

Model No.		<b>9553NB</b>	<b>9554NB</b>	<b>9555NB</b>
Capacity: mm (")	Depressed center wheel	100 (4)	115 (4-1/2)	125 (5)
	Wire cup brush	75 (3)	90 (3-1/2)	
	Abrasive disc	100 (4)	115 (4-1/2)	125 (5)
	Diamond wheel	100 (4)	115 (4-1/2)	125 (5)
No load speed: min.-1 = rpm		11,000	10,000	
Spindle thread		M10x1.5/ M10x1.25	DIN/ 5/8"-UNC	
Cord length: m (ft)		2.5 (8.2)		
Net weight: kg (lbs)		1.4 (3.1)		

## ► Standard equipment

### 9553NB

Depressed center wheel 100-36 .... 1  
 Lock nut wrench 20 ..... 1  
 Grip 36 complete ..... 1

### 9554NB

Depressed center wheel 115-36 .... 1  
 Lock nut wrench 28 ..... 1  
 Grip 36 complete ..... 1

### 9555NB

Depressed center wheel 125-36 .... 1  
 Lock nut wrench 35 ..... 1  
 Grip 36 complete ..... 1

**Note:** The standard equipment for the tool shown above may differ by country.

## ► Optional accessories

### 9553NB

Depressed center wheel 100-24  
 Depressed center wheel 100-36  
 Rubber pad 76  
 Sanding lock nut 10-30  
 Assorted 100mm abrasive discs  
 Wire cup brush 75  
 Wire bevel brush 85  
 Base assembly  
 Wheel cover  
 Dust extraction attachment

### 9554NB

Depressed center wheel 115-24  
 Depressed center wheel 115-36  
 Rubber pad 100  
 Sanding lock nut 14-48  
 Assorted 115mm abrasive discs  
 Super flange 47  
 Dust extracting wheel guards  
 Dust extracting wheel cover

### 9555NB

Depressed center wheel 125-24  
 Depressed center wheel 125-36  
 Rubber pad 115  
 Sanding lock nut 14-48  
 Assorted 125mm abrasive discs  
 Super flange 47  
 Dust extracting wheel guards  
 Dust extracting wheel cover

## ► Repair

**CAUTION: Disconnect the machine and remove the wheel for safety before repair/maintenance!**

### [1] NECESSARY REPAIRING TOOLS

Code No.	Descriptions	Purpose
1R028	Bearing Setting Pipe 20-12.2	Installing/removing Retaining ring S-12
1R045	Gear Extractor, large	Disassembling Bearing box
1R269	Bearing Extractor, small	Removing Ball bearing
1R291	Retaining Ring S and R Pliers	For Retaining rings S-12 and R-32
1R343	Retaining Ring Setting Jig	Installing Retaining ring S-12

### [2] LUBRICATION AND SEALING

Put 7g of Makita Grease N. No.1 into the gear room of gear housing.

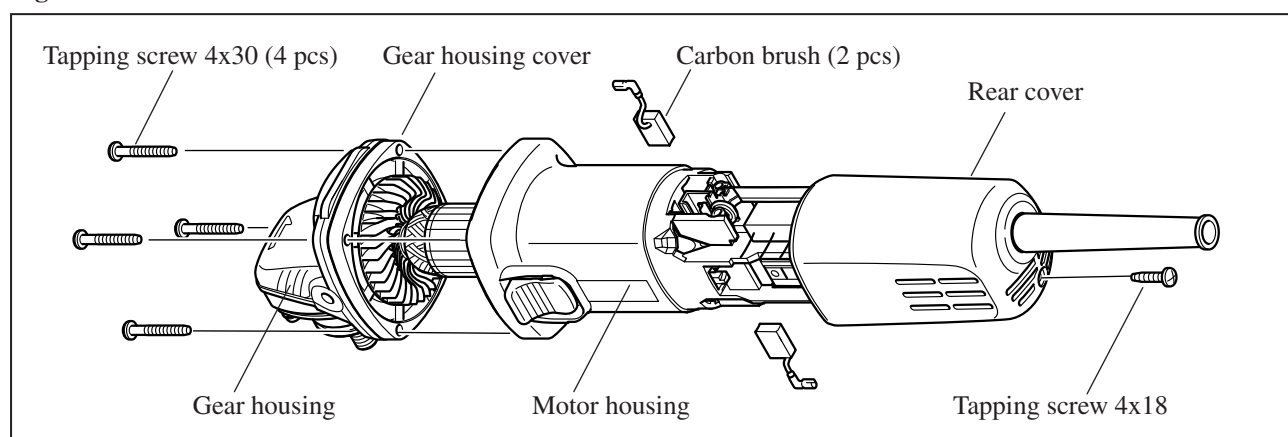
### [3] DISASSEMBLY/ASSEMBLY

#### [3] -1. Replacing Armature and Small Spiral Bevel Gear

##### DISASSEMBLY

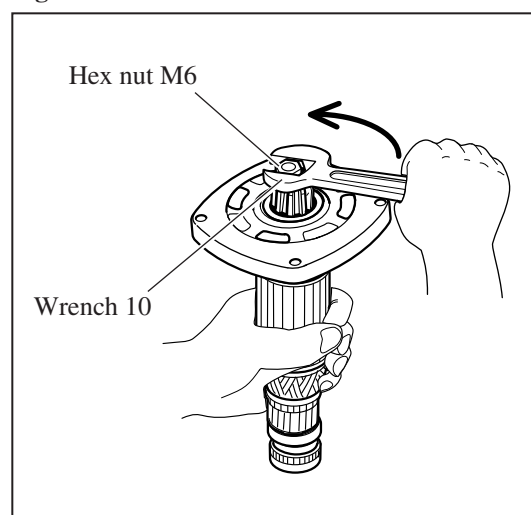
- 1) Remove tapping screw 4x18 and separate rear cover from motor housing. Then remove carbon brushes. (**Fig. 1**)
- 2) Unscrew four 4x30 tapping screws and remove the assembled unit of gear housing and armature. (**Fig. 1**)

**Fig. 1**

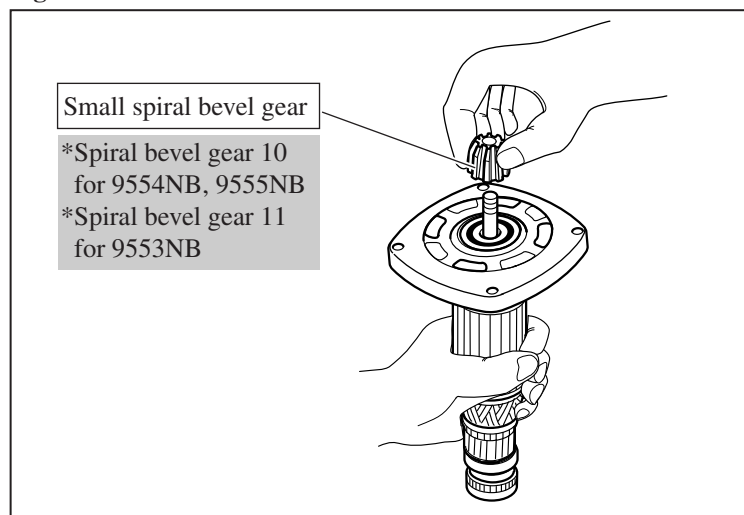


- 3) Pull off the assembled unit of armature and gear housing cover from gear housing.
- 4) Grip armature securely by hand, then remove hex nut M6 by turning counterclockwise with wrench 10. (**Fig. 2**)
- 5) Remove small spiral bevel gear by hand. (**Fig. 3**) If it is difficult to remove by hand, remove as described below:
  1. First, lubricate the gear with spray lubricant.
  2. Cover the gear with cloth.
  3. Then grip the gear covered with cloth using water pump pliers, and turn it.
- 6) Remove armature from gear housing cover with Gear Extractor, large (No.1R045).

**Fig. 2**



**Fig. 3**



## ► Repair

### [3] -1. Replacing Armature and Small Spiral Bevel Gear (cont.)

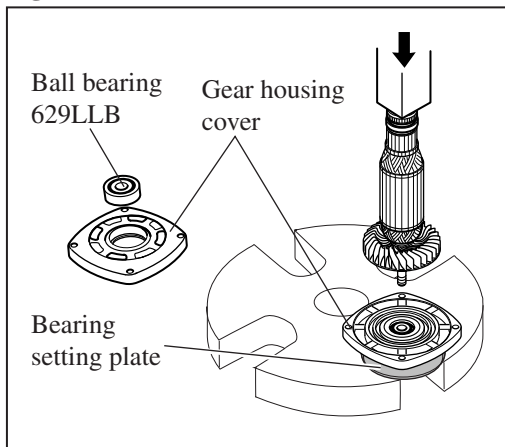
#### ASSEMBLY

Do the reverse of the disassembling steps.

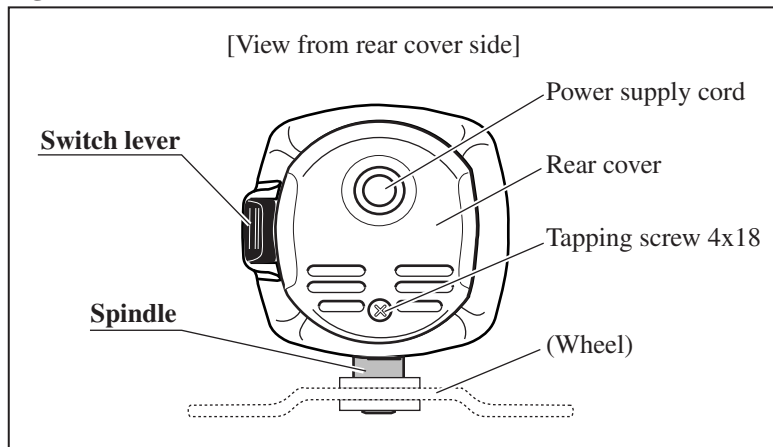
**Note:** Use arbor press and Bearing Setting Plate when fitting ball bearing 629LLB in gear housing cover. (**Fig. 4**)

**Important:** Assemble gear housing to motor housing so that switch lever can be operated with right thumb as illustrated in **Fig. 5**.

**Fig. 4**



**Fig. 5**

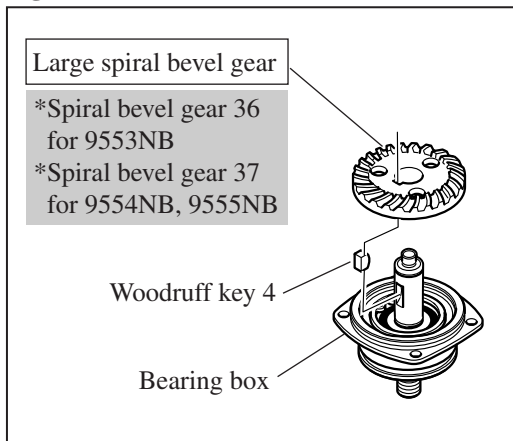


### [3] -2. Replacing Large Spiral Bevel Gear and Ball Bearing 6201DDW

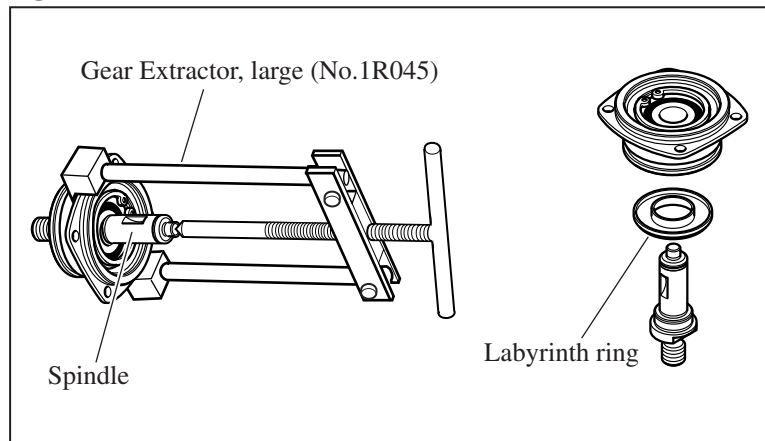
#### DISASSEMBLY

- 1) Remove bearing box from gear housing by unscrewing four M4x14 pan head screws.
- 2) Remove retaining ring S-12 and wave washer 12 from spindle with Retaining Ring S and R Pliers (No.1R291).
- 3) Large spiral bevel gear can now be removed by hand. Then remove woodruff key 4. (**Fig. 6**)
- 4) Remove spindle using Gear Extractor, large (No.1R045). Now labyrinth ring can be removed. (**Fig. 12**)

**Fig. 6**

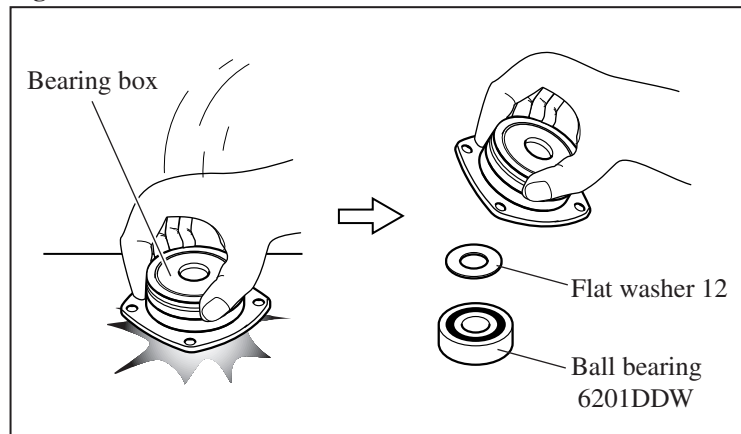


**Fig. 7**



- 5) Remove retaining ring R-32 from bearing box with Retaining Ring S and R Pliers (No.1R291).
- 6) By striking bearing box against the surface of a work table, ball bearing 6201DDW and flat washer 12 can be removed from bearing box as illustrated in **Fig. 8**.  
If it is difficult to remove the ball bearing, remove using arbor press.

**Fig. 8**



## ► Repair

### [3] -2. Replacing Large Spiral Bevel Gear and Ball Bearing 6201DDW (cont.)

#### ASSEMBLY

Do the reverse of disassembling steps.

**Important:** Do not forget to install labyrinth ring because it prevents dust from entering into bearing box. (**Fig. 9**)

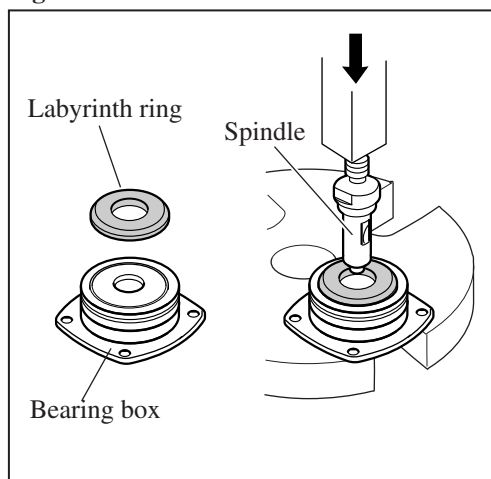
#### How to fit retaining ring S-12 in place

See **Fig. 10**.

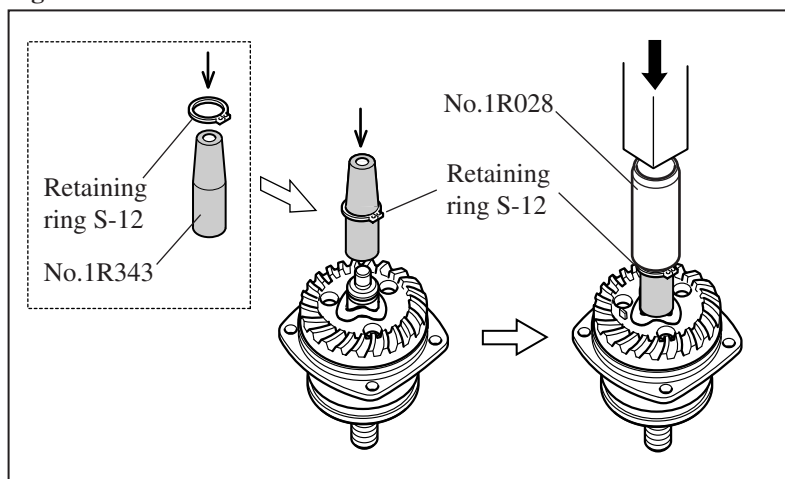
After installing large spiral bevel gear and wave washer 12 on spindle;

- 1) Put retaining ring S-12 on Retaining Ring Setting Jig (No.1R343) from the tapered end of the jig.
- 2) Put the jig onto spindle, then put Bearing Setting Pipe 20-12.2 (No.1R028) over the jig.
- 3) Using arbor press, press down the pipe till the retaining ring is securely fitted in place on the spindle with a snap.

**Fig. 9**



**Fig. 10**



### [3] -3. Disassembling/Assembling Shaft Lock Mechanism

#### DISASSEMBLY

- 1) Remove bearing box from gear housing.
- 2) Pull off shoulder pin 4 with pliers while pushing pin cap with finger. (**Fig. 11**)

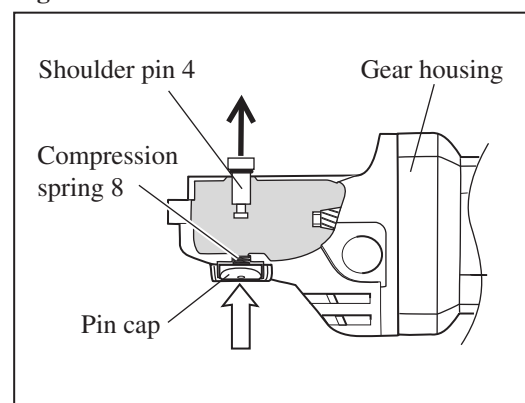
**Note:** Do not pull off shoulder pin 4 without holding pin cap because compression spring 8 would sling pin cap.

#### ASSEMBLY

Push shoulder pin 4 through gear housing and compression spring 8 into pin cap.

**Note:** Do not reuse removed pin cap because removal of shoulder pin 4 damages the inside surface of pin cap, producing plastic dust. Therefore, be sure to use a new pin cap for replacement and to remove all the plastic dust on shoulder pin 4.




**Fig. 11**

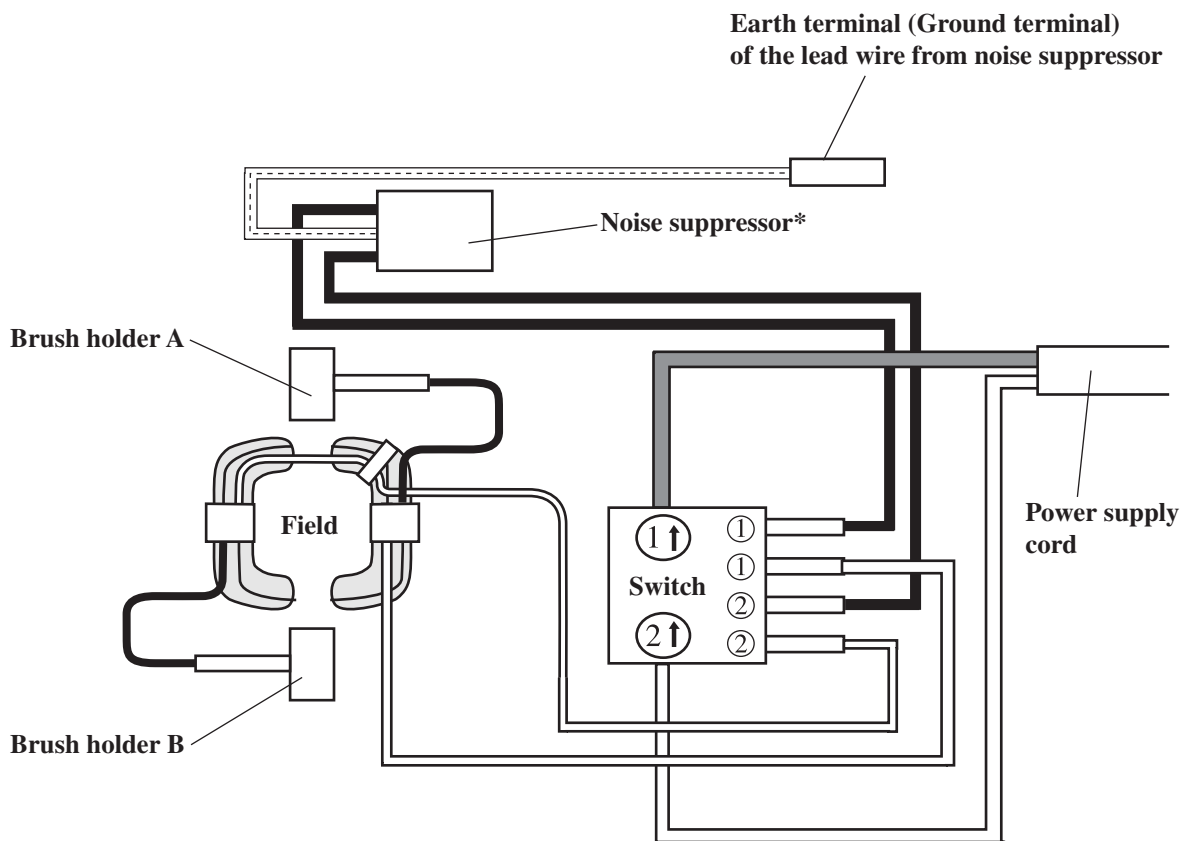


### [3] -4. Tightening Tapping Screws That Fasten the Field

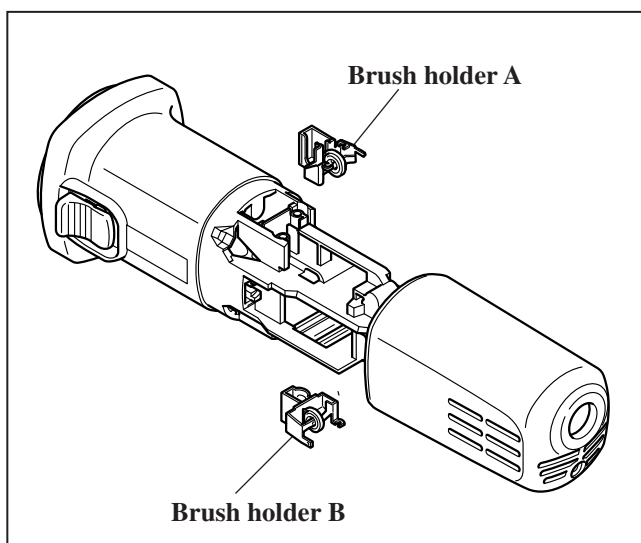
Tighten the two tapping screws that fasten baffle plate and field to the recommended torque of 1.1 - 1.3 Nm.

► **Circuit diagram**

Color index of lead wires' sheath	
Black	
White	
Clear	



\*Some countries do not use noise suppressor

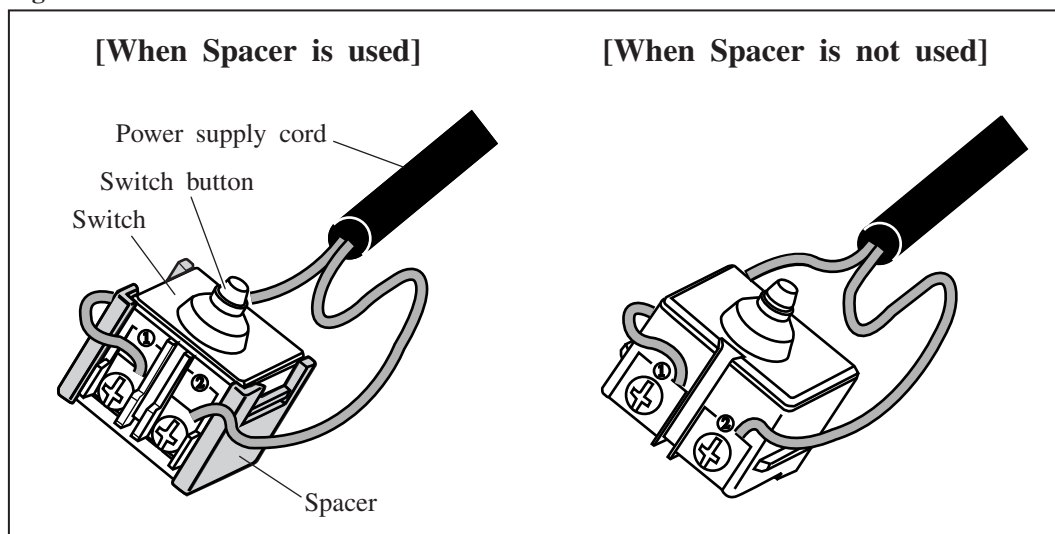


## ▶ Wiring diagram

### [1] Connecting Lead Wires of Power Supply Cord with Switch

Connect the lead wires with switch as illustrated in Fig. 12.

Fig. 12

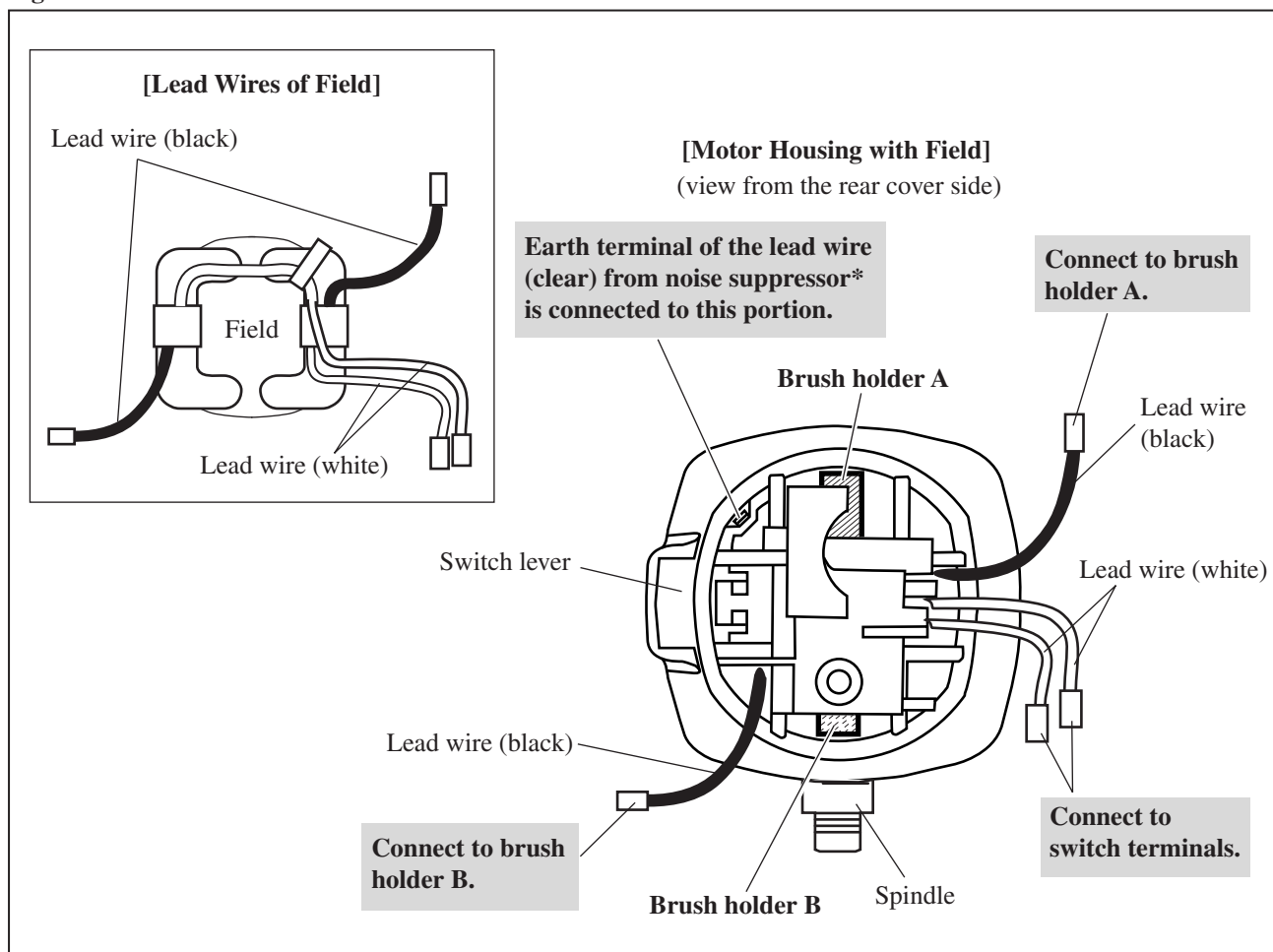


### [2] Wiring of Field Lead Wires in the Rear of Motor Housing

#### [2] -1. Rear End

Route the field lead wires as illustrated in Fig. 13 - 16.

Fig. 13



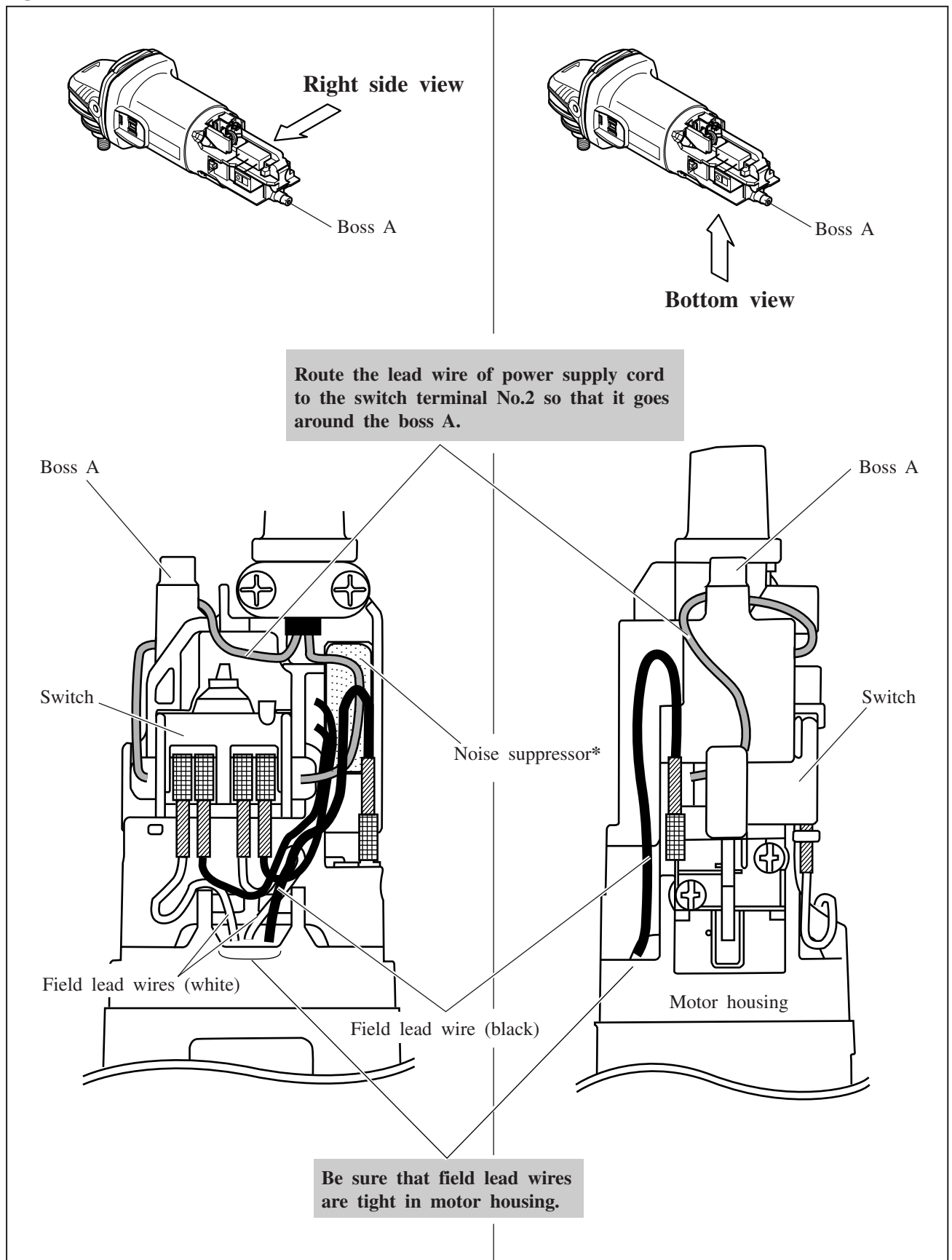
\*Some countries do not use noise suppressor.

► **Wiring diagram**

[2] **Wiring of Field Lead Wires in the Rear of Motor Housing (cont.)**

[2] -2. **Right Side and Bottom**

Fig. 14



\*Some countries do not use noise suppressor.

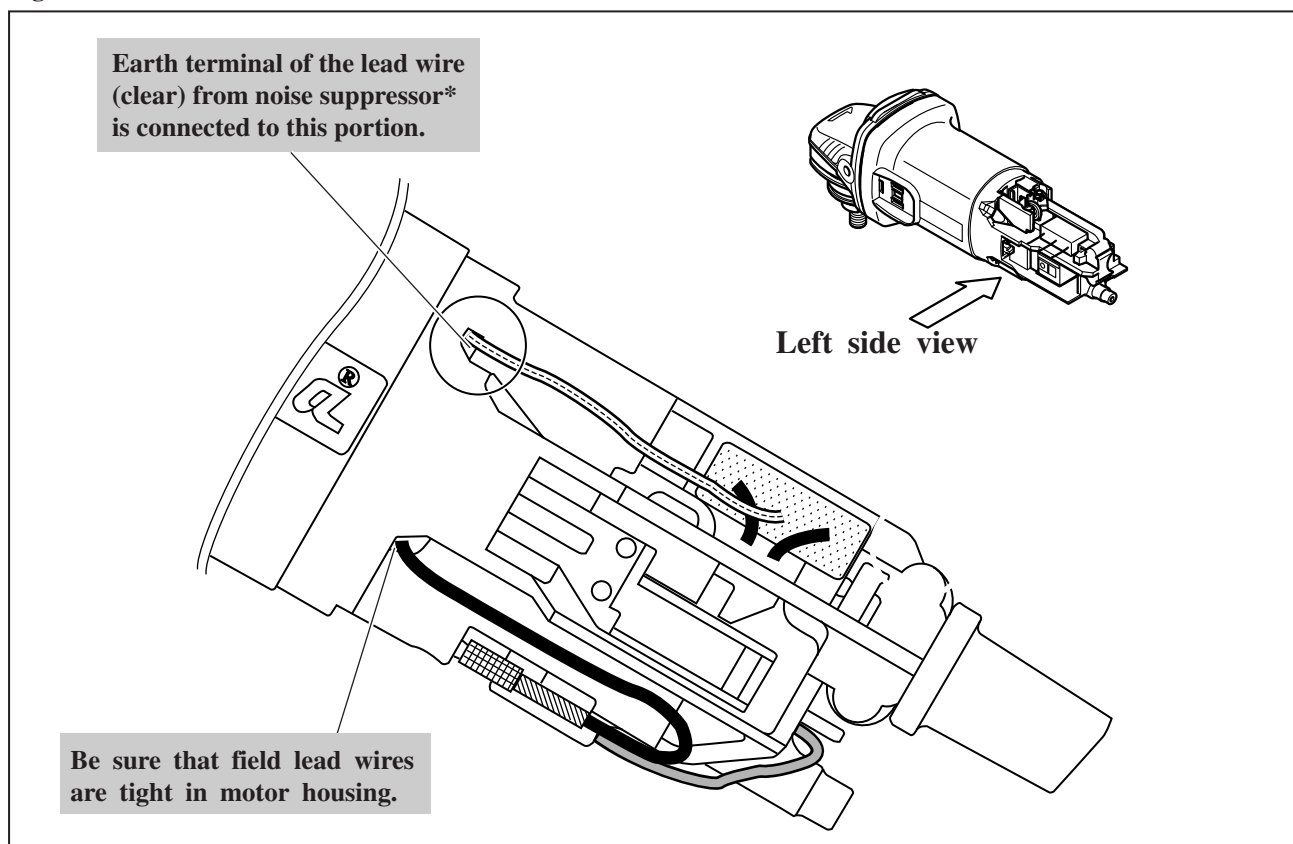


► **Wiring diagram**

[2] **Wiring of Field Lead Wires in the Rear of Motor Housing (cont.)**

[2] -3. **Left Side**

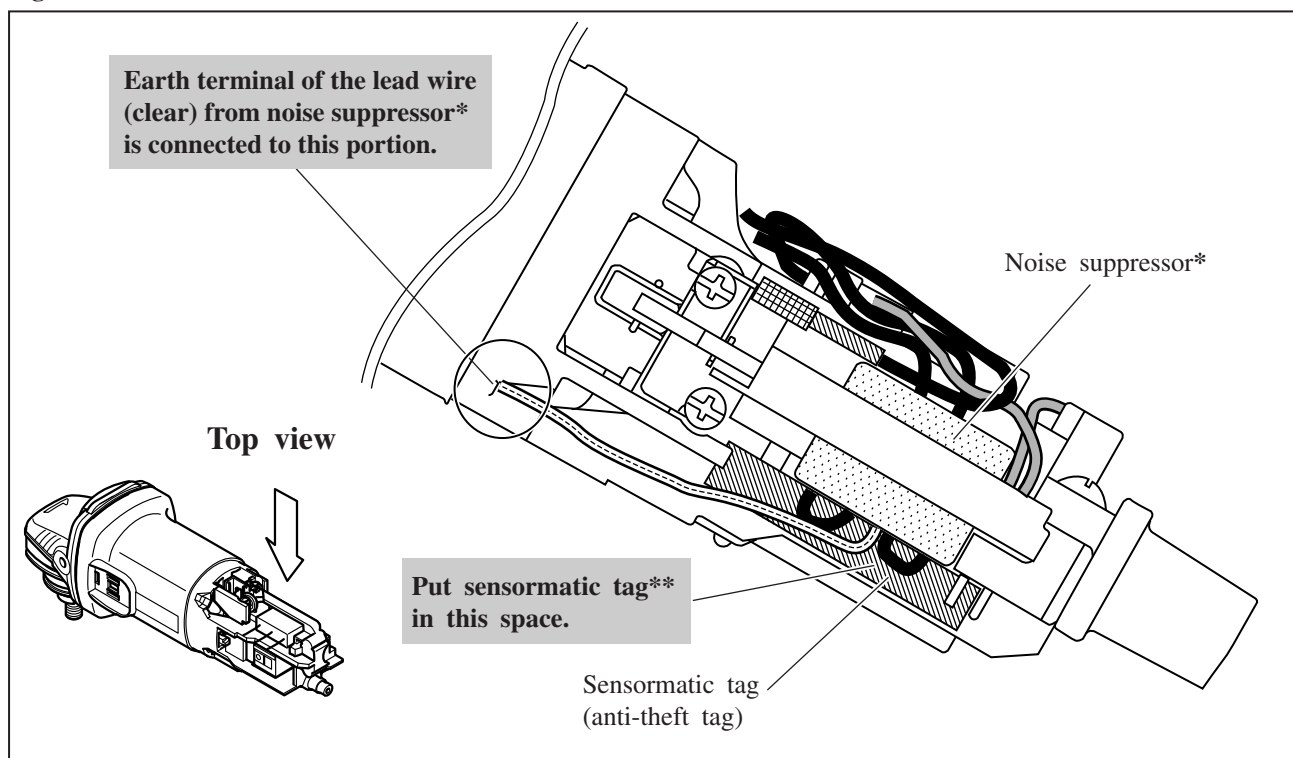
Fig. 15



\*Some countries do not use noise suppressor.

[2] -4. **Top**

Fig. 16



\*Some countries do not use noise suppressor.

\*\*Some countries do not use sensormatic tag.