

T ECHNICAL INFORMATION



New Tool

Models No. ▶ 9403

Description ▶ 100mm belt sander

CONCEPTION AND MAIN APPLICATIONS

Model 9403 is a handy and convenient belt sander that inherits models 9401 and 9402. Sanding efficiency and capacity of dust collection have been raised as well as noise and weight have been lowered.

Power consumption is 1200W,
and belt dimensions are 100mm(4") wide and 610mm(24") long.

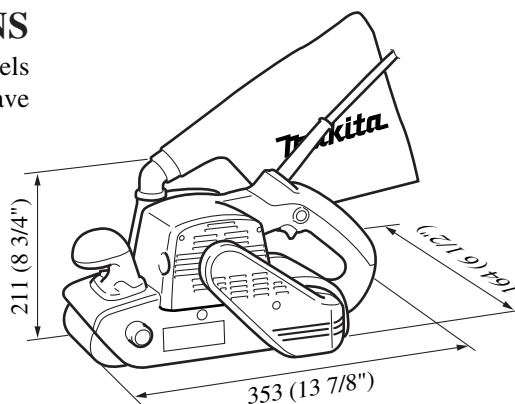

► Specifications

Voltage (V)	Current (A)	Cycle (Hz)	Continuous Rating (W)		Max. Output(W)
			Input	Output	
100	13	50/60	1200	520	1250
110	11	50/60	1200	520	1250
120	11	50/60	1200	520	1250
220	5.7	50/60	1200	520	1250
230	5.5	50/60	1200	520	1250
240	5.3	50/60	1200	520	1250

Belt speed	500m/min (1.640 ft/min)
Belt size	100mm (4") x 610mm (24")
Net weight	5.9kg (13.1lbs)
Power supply cord	5m (16.4ft)

► Standard equipment

Dust bag ass'y ----- 1pc.
Abrasive belt AA80 ----- 1set (5pcs.)

► Optional accessories

Abrasive belt, AA and CC each of #40, #60, #80, #100, #120, #150, #180, #240
Carbon plate,
Hose complete 28-1.5,
Hose complete 28-3.0,
Joint 25

► Repair

(1) Replacement of armature

a) Unscrew tapping screws; two PT4x45 and one PT4x18 (one CT4x40 in model 9403, and one CT4x16 in model 9921). Remove dust collector cover and separator so that dust collector fan 80 appears.

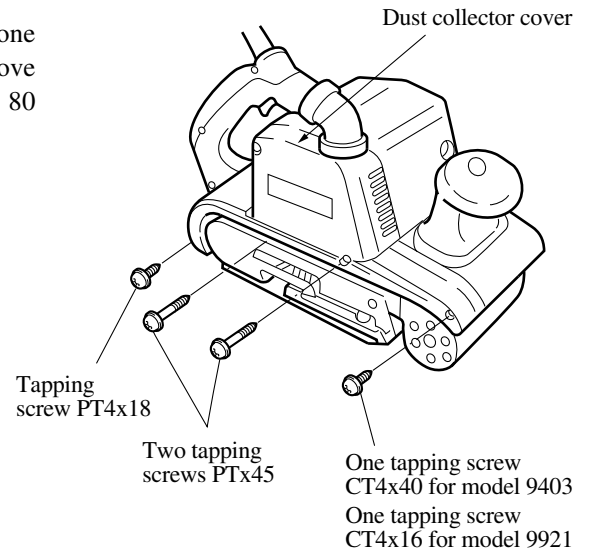

b) Unscrew tapping screw CT4x16 and remove belt cover.

c) Take off holder cap and remove carbon brush.

d) Remove synchro-belt 9-354.

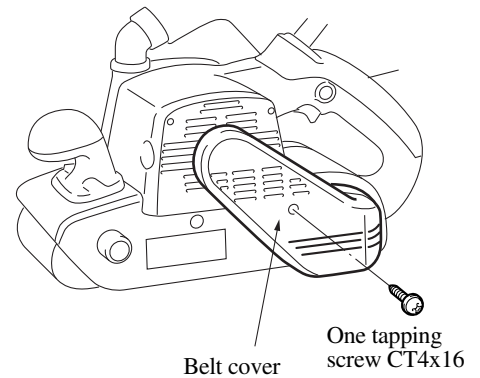

e) Turn pulley 10-24.1 clockwise and remove it.

(Note that the pulley 10-24.1 is fixed with a left-handed screw so do not turn it counterclockwise.)

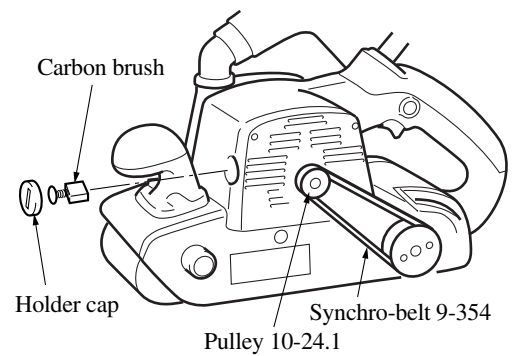

f) Unscrew cross-slot pan-head screw M5x12 that fixes dust collector fan 80, and remove fan 80.

g) Remove two tapping screws PT4x18 which fix dust collector bracket so that armature can be taken off together with dust collector bracket.

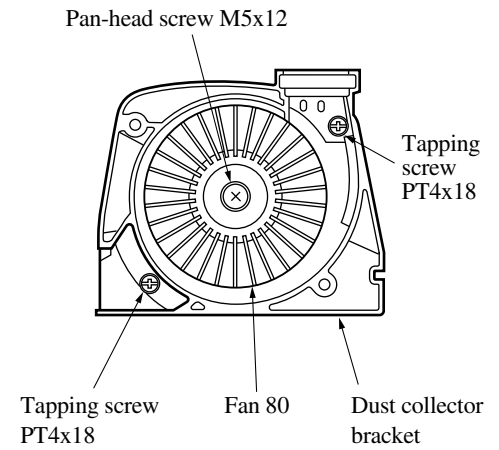

(2) Removal of driving roller

a) Remove belt cover and synchro-belt 9-354 with the same procedures as the replace of armature.

b) Unscrew three tapping screws CT4x16 and remove gear cover.

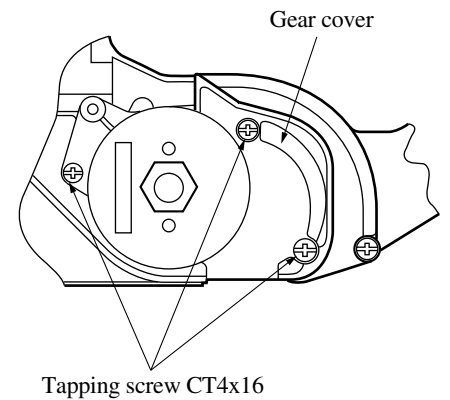

c) Insert lock nut wrench 28 into two holes of helical gear 43 complete, and fix the helical gear complete. Use 24mm box wrench to turn driving roller clockwise and the driving roller can be removed.

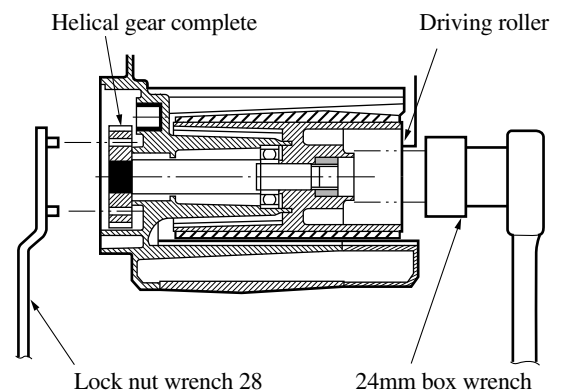

(3) Caution for replacement of edge slider complete

When assembling edge slider complete, be sure to install it so that the ceramic plate side will be positioned inside as shown in the figure below.

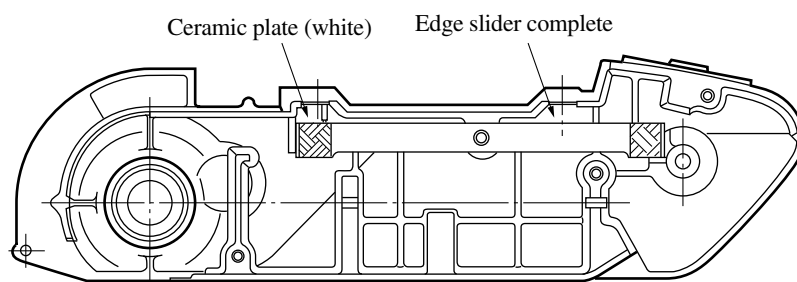

▶ Wiring diagram

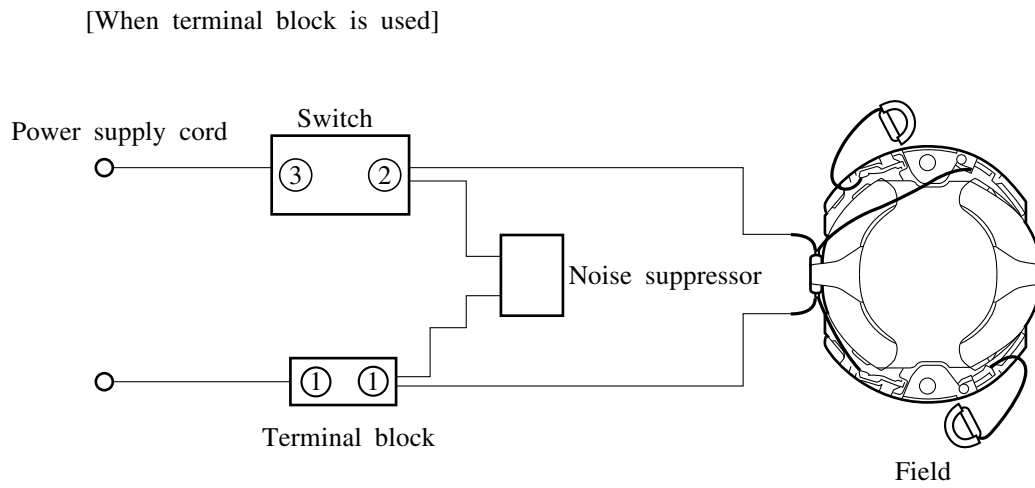
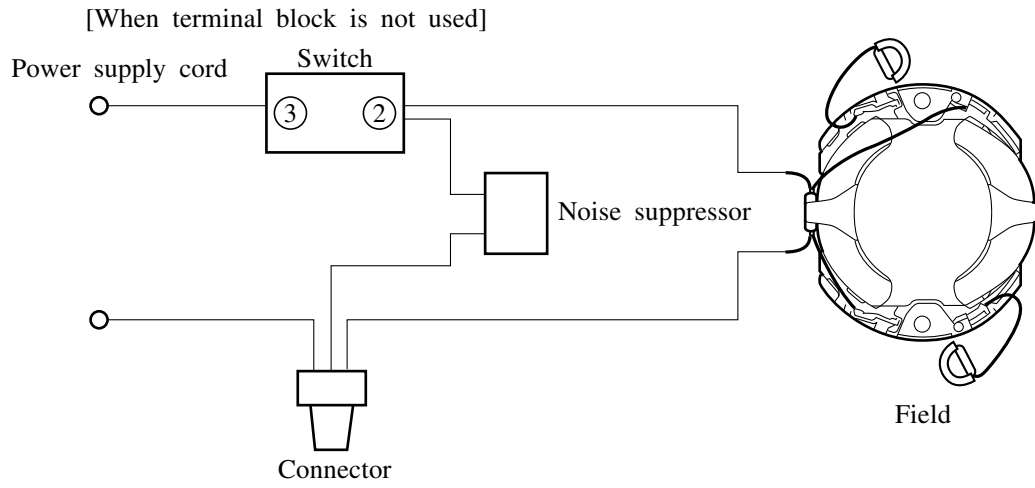

Noise suppressor is not used depending on countries.