

T ECHNICAL INFORMATION



New Tool

Models No. ▶ 9029

Description ▶ 230mm (9") Disc Grinder

CONCEPTION AND MAIN APPLICATIONS

Long-expected disc grinders are offered by Makita now. Their power, maneuverability and dust-proof mechanism are outstanding. Try them! They are ideal for both grinding and cut-off jobs.

Model 9029S has soft start feature.

(Note)

Model 9029S is offered to 200V-240V areas and countries only

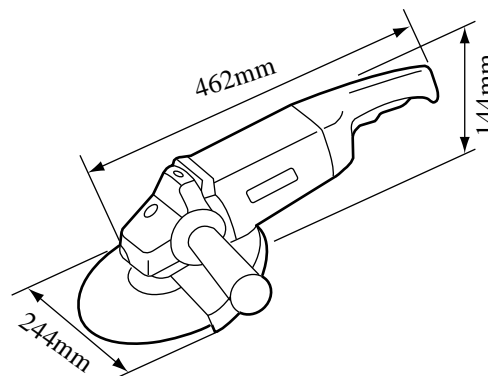

▶ Specifications

Voltage (V)	Current (A)	Cycle (Hz)	Continuous Rating (W)		Max. Output(W)
			Input	Output	
100	15.0	50/60	1,430	600	2,600
115	15.0	50/60	1,650	800	2,600
200	10.5	50/60	1,430	1,200	3,500
220	9.6	50/60	2,000	1,200	3,500
230	9.2	50/60	2,000	1,200	3,500
240	8.8	50/60	2,000	1,200	3,500

No load Speed: 6,600 R/min.

Capacities

Depressed Center Wheel: 230 mm (9")

Wire Cup Brush : 110 mm (4-3/8")

Net weight: 5.5 kg (12.1 lbs)

▶ Standard equipment

Lock Nut Wrench 35, Grip 35

▶ Optional accessories

Dust Collecting Wheel Guard, Inner Flange 47 (DIN spec. Spur Flange),

Depressed Center Wheel 24P, 36P, Inner Flange 78 (For cut-off wheel),

Outer flange 78 (For cut-off wheel), Loop Handle, Wire Cup Brush 110

► Repair

(1) Replacing of armature

- i) Remove wheel, wheel cover, and bearing box respectively.
(Refer to owner's manual for wheel cover removing method.)
- ii) Remove gear housing and armature as one body after carbon brush is removed.
- iii) Unscrew bearing retainer attaching screw (Mounted from gear housing side with M5 x 10 and M5 x 20.) and remove armature.
- iv) Be sure to mate bearing retainer guide portion with projected portion of bearing retainer before inserting and tighten with hex socket head bolt when armature is assembled to gear housing. Adhesive is applied to hex socket head bolt then be sure replace with new one once the bolt is removed.

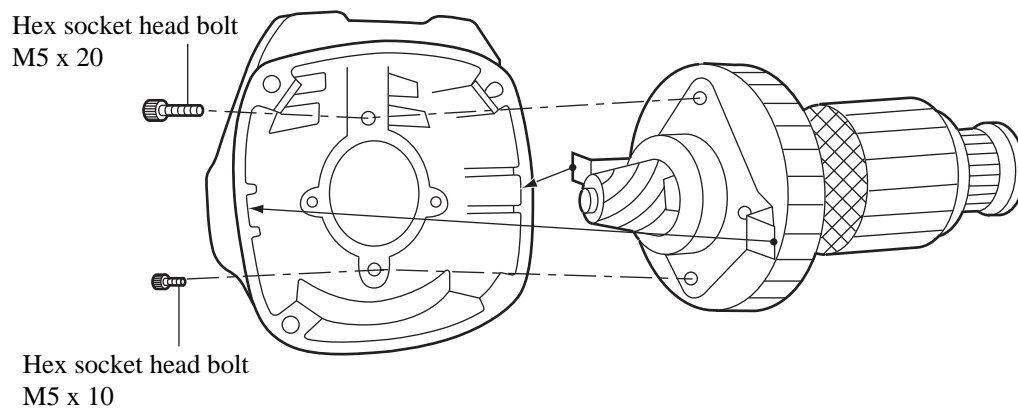

(2) Replacing spiral bevel gear 12

(1) Replace spiral bevel gear 12 after removing armature from gear housing according to armature replacing method. Spiral bevel gear can not be replaced when armature is assembled in gear housing.

(3) Malfunction of shaft lock portion

When activation of shaft lock portion becomes inactive due to contaminated dust.

- i) Dismount pin cap using minus driver or etc. and remove dust inside shaft lock portion.
- ii) Make pin cap mate with hole and depress it to mount on pin again.

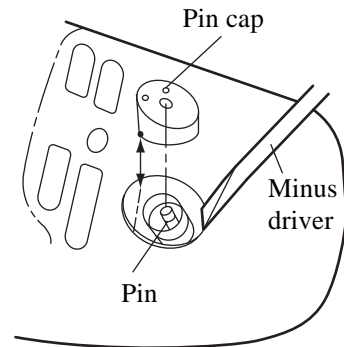

(4) Malfunction of handle turning

When handle turning is prevented from contaminated dust.

- i) Remove handle fixing and mounting screws, dismount handle L and R, and remove dust in motor housing and rotating portion of handle L and R to clean.
- ii) Tighten handle mounting screw M4 x 25 with tightening torque 10~15kg-cm (0.7~1.1ft-lbs) and handle fixing screw M6 x 85 with 20~30kg-cm (1.4~2.2ft-lbs) respectively.

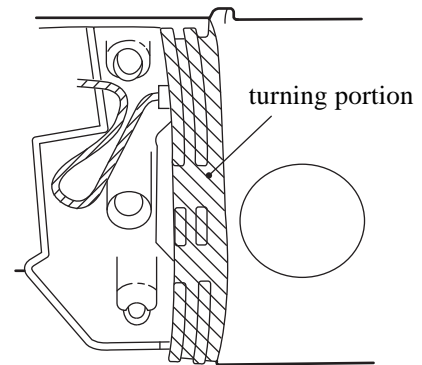

(5) Reference information: Angle adjusting for gear housing

Gear housing angle can be changed in four position at 90°Kinterval.

- i) Remove wheel and wheel cover.
- ii) Remove carbon brush then dismount gear housing and armature without separating them from motor housing.
- iii) After cutting off baffle plate partially at two portions where interference is occurred with projected portions of motor housing using knife then mate gear housing and motor housing at required position to attach.
- iv) Mount gear housing at required position.
(Note: Do not let users make gear angle adjustment.)

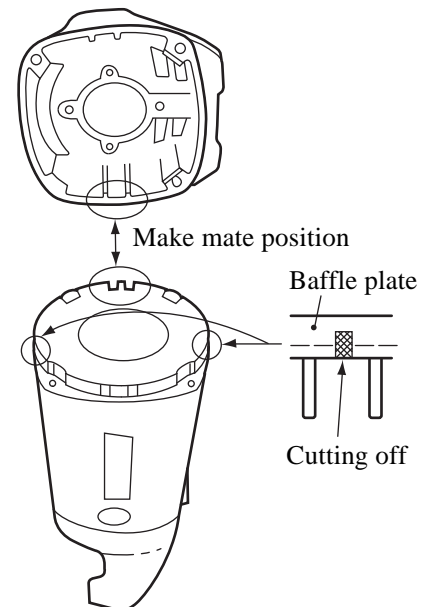

► Wiring Diagram

(1) 9029

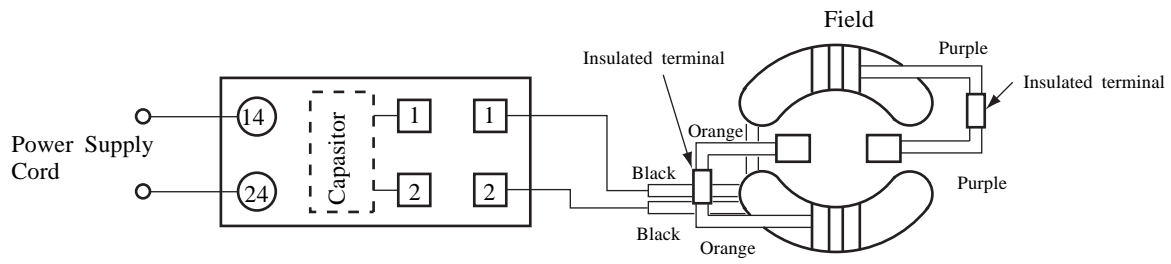

(Note) Condenser is not used in some areas.

(2) 9029S

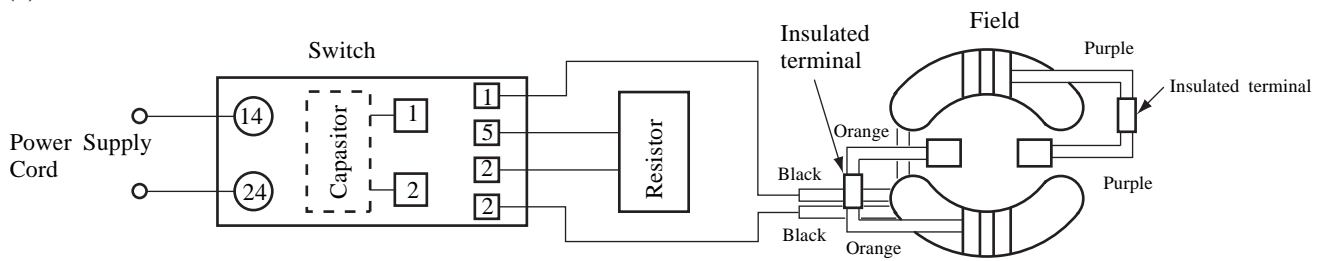

(Note) Condenser is not used in some areas.