

# T ECHNICAL INFORMATION



- Models No.** ▶ 9015B
- Description** ▶ 125mm(5") Angle Grinder  
150mm(6") Angle Grinder

## CONCEPTION AND MAIN APPLICATIONS

Model 9015B(and 9016B) has been developed aiming at improving our most popular 5"(& 6") grinding model 9005B(9006B). Its main features are

- 1) Special anti-dust protections for armature, field and bearing provide an extended service life of the grinder.
- 2) A longer life of armature with ticker commutators.
- 3) More efficient cooling system for motor.
- 4) More comfortable and easier operation with larger trigger switch and spindle lock button.

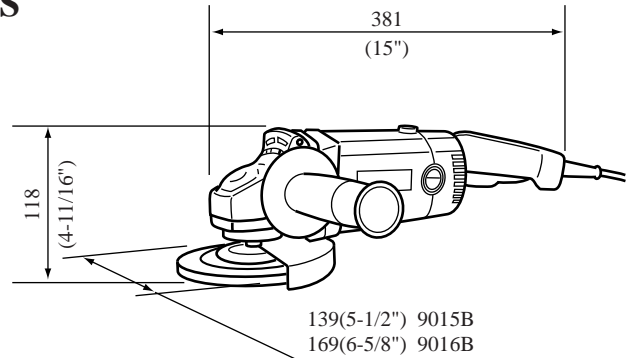

## ► Specifications

Voltage (V)	Current (A)	Cycle (Hz)	Continuous Rating (W)		Max. Output(W)
			Input	Output	
100	11	50/60	1050	550	1600
110	9.6	50/60	1050	550	1600
120	12.5	50/60	1370	800	1600
200	5.5	50/60	1050	550	1600
220	5.0	50/60	1050	550	1600
230	4.8	50/60	1050	550	1600
240	4.6	50/60	1050	550	1600

<b>No load speed(R.P.M.)</b>	10000rpm (UK:11,500rpm)
<b>Size of depressed center wheel</b>	125mm(5")/150mm(6") x22mm(7.8") x6mm(1/4") Outer diameter Arbor diameter Thickness
<b>Cord length</b>	2.5m(8.2ft)
<b>Net weight A</b>	2.4Kg(5.3lbs)
<b>Net weight B(9015B/9016B)</b>	2.9Kg(6.4lbs)/3.0Kg(6.6lbs)

<Note> Net weight A ----- without wheel,wheel cover, inner flange, lock nut and power supply cord  
Net weight B ----- without wheel and power supply cord

## ► Standard equipment

- Lock Nut Wrench 35----- 1 pc.
- Depressed Center Wheel 125-36----- 1 pc. (9015B)
- Depressed Center Wheel 150-36----- 1 pc. (9016B)
- <Note> The standard equipment may differ from country to country.

## ► Optional accessories

- Depressed Center Wheel 125/150-24,36
- Wire Cup Brush 90
- Wheel Cover (for Wire Cup Brush)
- Wheel Cover (for dust collect) for 9015B
- Rubber Pad
- Lock Nut 16-48
- Abrasive Disc 125/150-24,30,50,80, 100,120

The standard equipment for the tools shown may differ form country to country

## ► Repair

### (1) Replacing of armature

- 1) Remove the wheel stone and the wheel cover, respectively.
- 2) Remove the carbon brush.
- 3) Disconnect the tapping screw PT5x30(4 pieces)for mounting the gear housing and motor housing and then remove the armature.

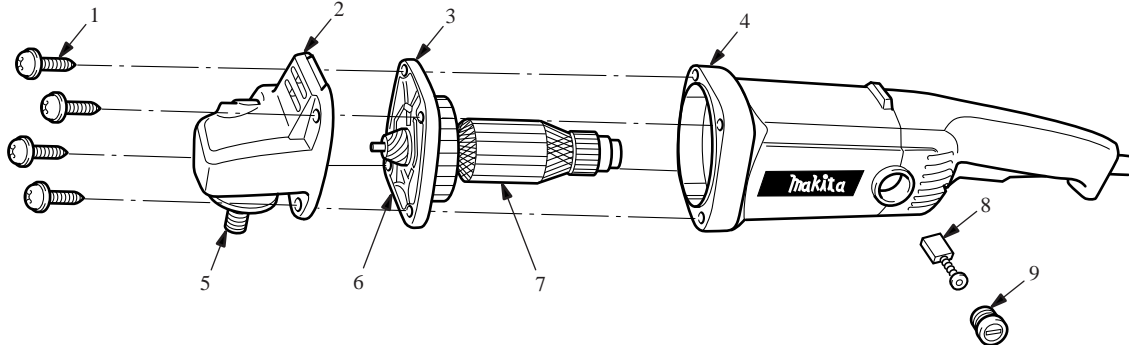

- 1) Remove the wheel stone and the wheel cover, respectively.
- 2) Remove the tapping screw CT5x16(4 pieces) for mounting the bearing box.
- 3) The spiral bevel gear 33 is inserted in the spindle. Disassemble it in a way shown below.

\*To assemble the gear housing and gear housing cover on the motor housing, set in a way that un-processed edge face on the gear housing cover faces screw side of the spindle.

### (2) Replacing of the spiral bevel gear 33

- 1) Remove the wheel stone and the wheel cover, respectively.
- 2) Remove the tapping screw CT5x16(4 pieces) for mounting the bearing box.
- 3) The spiral bevel gear 33 is inserted in the spindle. Disassemble it in a way shown below.

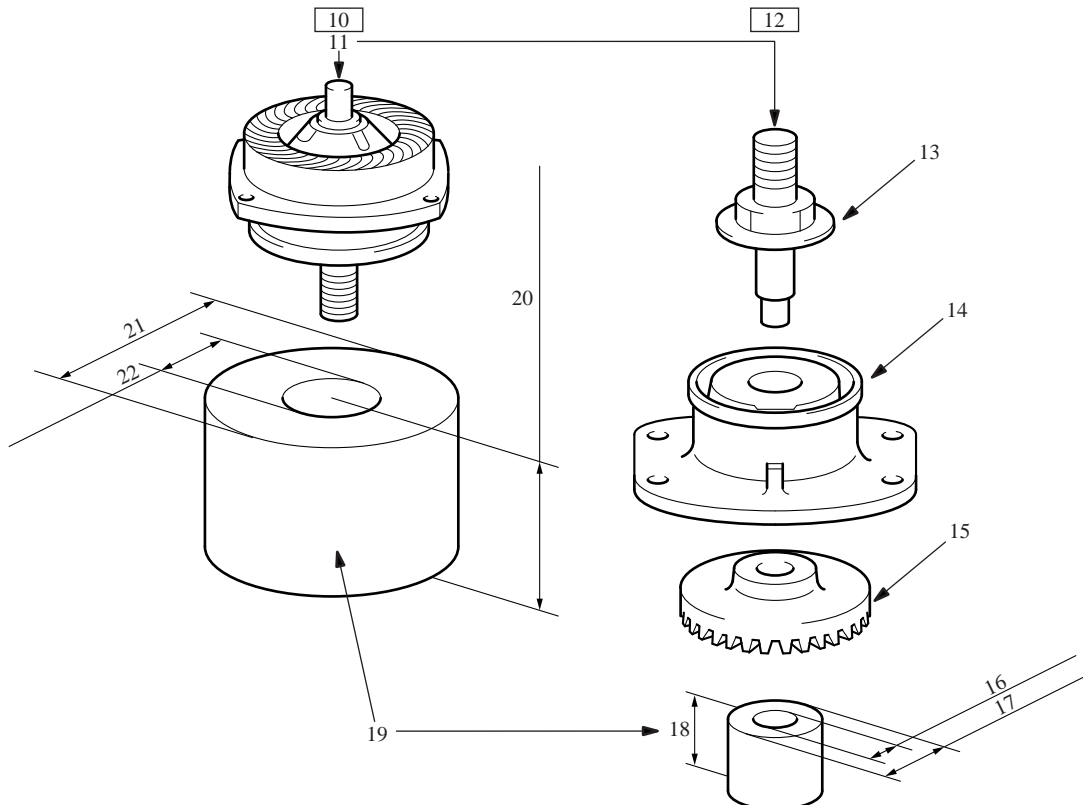

Turning the gear housing and gear housing cover in 4 directions together every 90° enables to change angle between wheel stone and handle.

(Note) They can turn while the gear housing cover is housed in the motor housing.

23

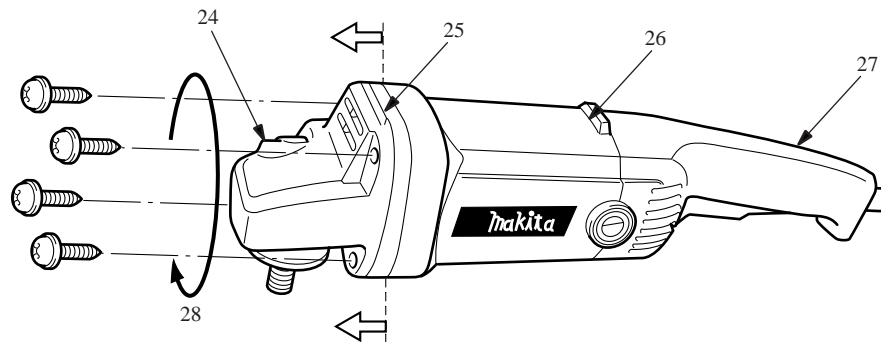

### ► Circuit diagram

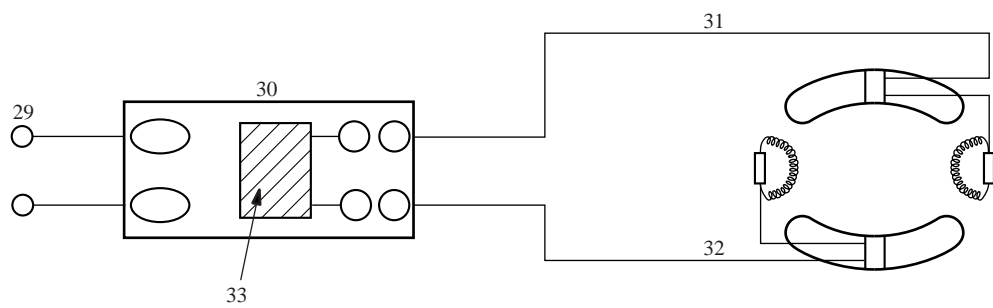

(3) Reference information : angle change between wheel stone and handle