

TECHNICAL INFORMATION



PRODUCT

P 1 / 8

Models No. ▶ 6824N, 6824NTP

Description ▶ Drywall Screwdrivers

CONCEPTION AND MAIN APPLICATIONS

Mod.6824N and 6824NTP have been developed as a new version of 6824 series model. Their feature is "Normal Clutch" which is convenient for unscrewing. 6824NTP is equipped with 15m (50ft) three-wire cord with twist plug.

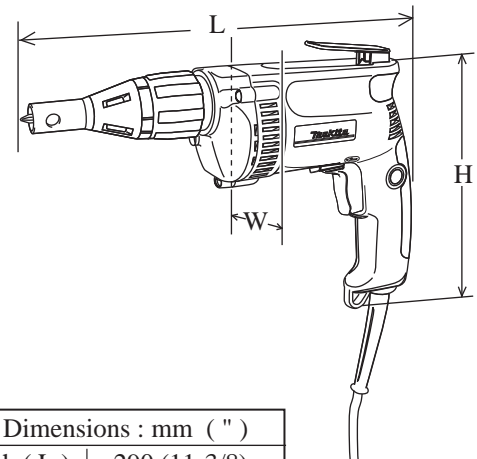

Dimensions : mm (")	
Length (L)	290 (11-3/8)
Height (H)	218 (8-5/8)
Width (W)	70(2-3/4)

► Specification

Voltage (V)	Current (A)	Cycle (Hz)	Continuous Rating (W)		Max. Output(W)
			Input	Output	
120	6.5	50 / 60	(710)	340	590

Model No.	6824N	6824NTP
Rated ampere with 120V : A	6.5	
No load speed : min -1=rpm	0 - 4,500	
Driving shank	6.35mm (1/4") hex	
Capacity : mm (")	Self drilling screw	6 (1/4)
	Drywall screw	5 (3/16)
Variable switch	Yes	
Reverse switch	Yes	
Protection from electric shock	by double insulation	by grounding
Cord length : m (ft)	2.5 (8.2)	15 (50)
Net weight : Kg (lbs)	1.4 (3.1)	

► Standard equipment

- * Philips bit 2 - 25 1 pc.
- * Magnetic socket bit 6.35-76 1 pc.

< Note 1 > The above mentioned items are installed in advance in our fabric.

< Note 2 > The standard equipment for the tool shown may differ from country to country.

► Optional accessories

- * Philips bit 1 - 25
- * Philips bit 2 - 25
- * Philips bit 3 - 25
- * Magnetic connect bit 6.35-60
- * Adjust sleeve complete for magnetic connect bit 6.35-76

< 1 > Lubrication

Apply MAKITA grease N. No.1 to the following portions marked with black triangle to protect parts and product from unusual abrasion.

Item No.	Parts.	The portion to be lubricated
7	Gear housing complete	approx. 4g (0.14 oz) to the space for helical gear 43
11	Spindle	* Cam portion where contacts helical gear's cam. * Surface where contacts gear housing.
12	Compression spring 12	Its whole part
13	Collared pin 8	Its whole part
14	Helical gear 43	Teeth portion

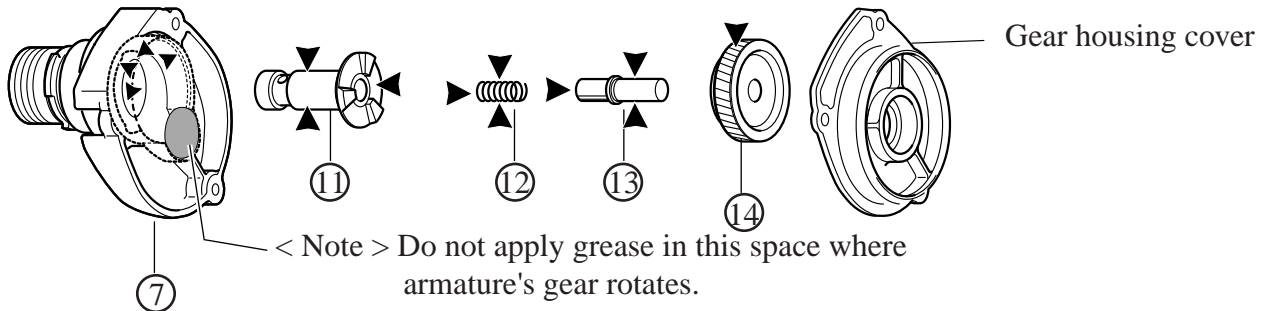

< 2 > Removing armature, ball bearing 608VV and ball bearing 607LLB

- (1) Remove handle cover by unscrewing 3 pcs. of tapping screws 4x25. And then, take off carbon brushes. See Fig. 1.
- (2) Model 6824N: Remove gear section (locator, lock ring, gear housing complete and gear housing cover) from motor housing by unscrewing 3 pcs. of tapping screws 4x25. Then, armature can be separated from motor housing together with gear section See Fig. 2.

Model 6824NT: Pull out gear section approx. 10mm from motor housing. Disconnect grounding lead wire's terminal by unscrewing pan head screw M4x8. Remove in the same way as model 6824N. See Fig. 3.

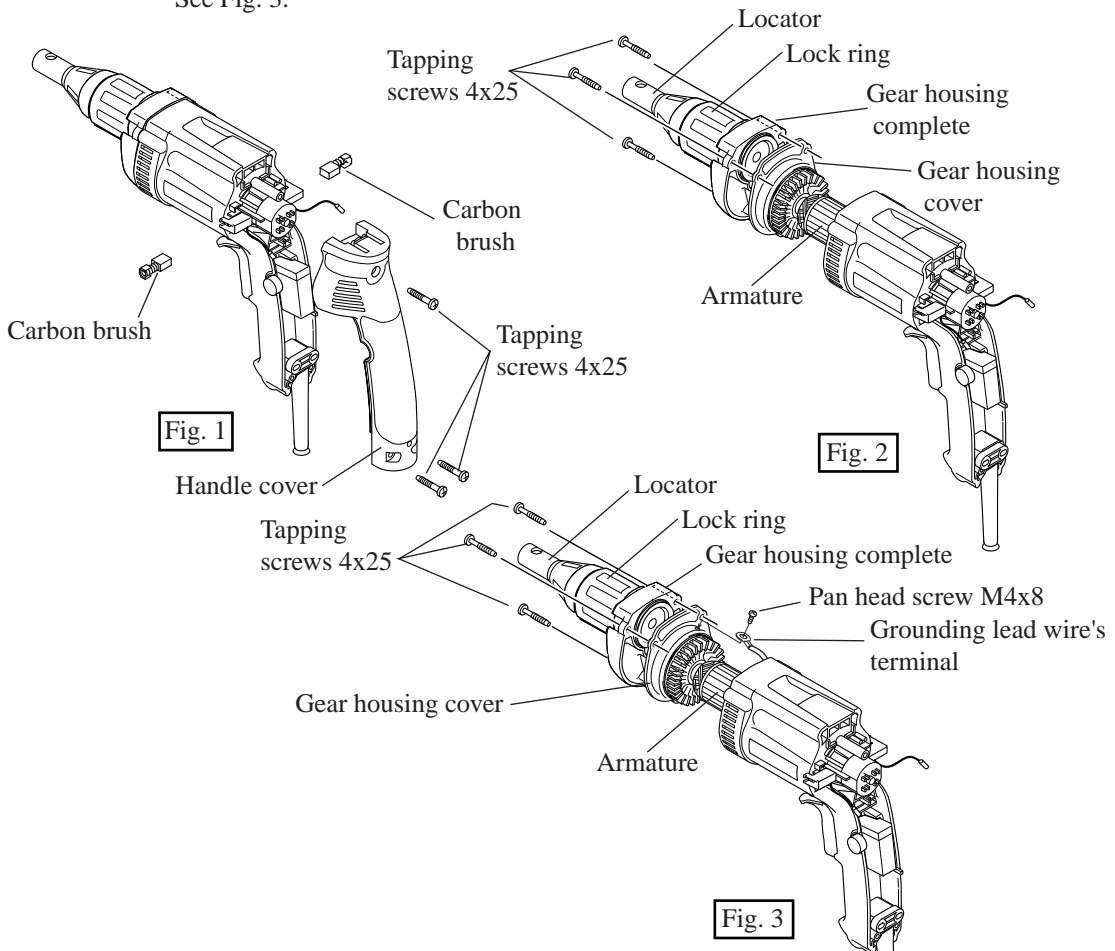

- (3) After separating armature from gear housing cover, remove rubber ring 19.
 And then, remove ball bearing 607LLB with 1R269 "Bearing extractor", and insulation washer. See Fig. 4.

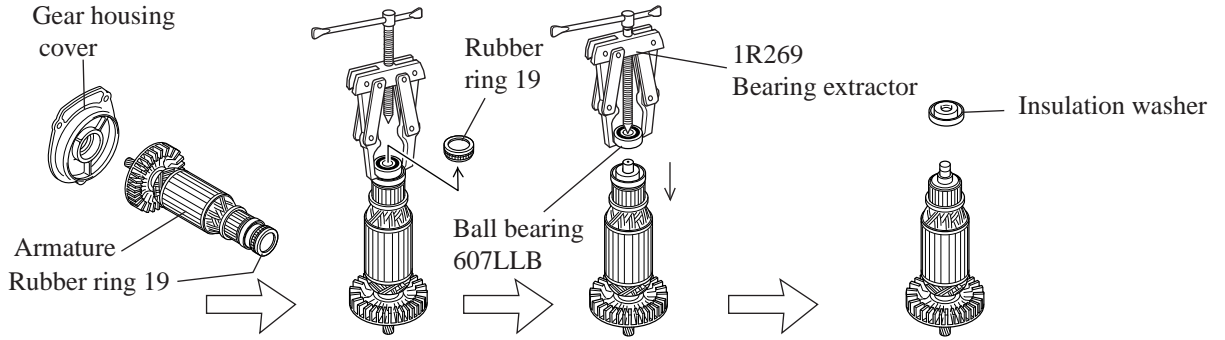

Fig. 4

- (4) Remove ball bearing 608VV and ring 8 at a time with 1R269 "Bearing extractor".
 Remove flat washer 8. See Fig. 5.

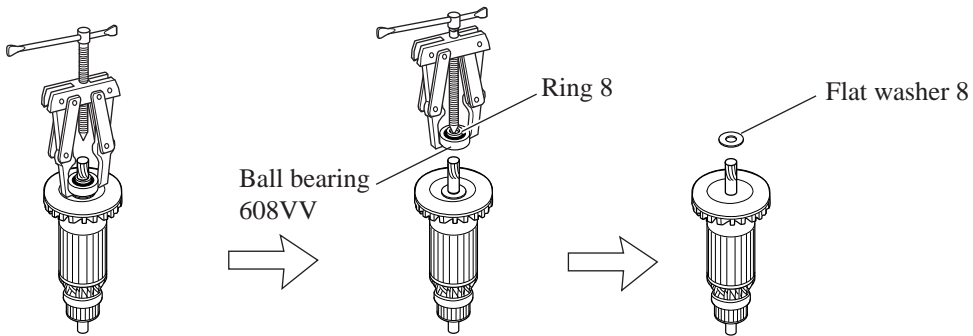

Fig. 5

< 3 > Mounting armature, ball bearing 608VV and ball bearing 607LLB

- (1) Mount flat washer 8. And mount ball bearing 608VV with arbor press, and ring 8. See Fig. 6.
 (2) Mount insulation washer. And mount ball bearing 607LLB with arbor pres, and rubber ring 19. See Fig. 7.

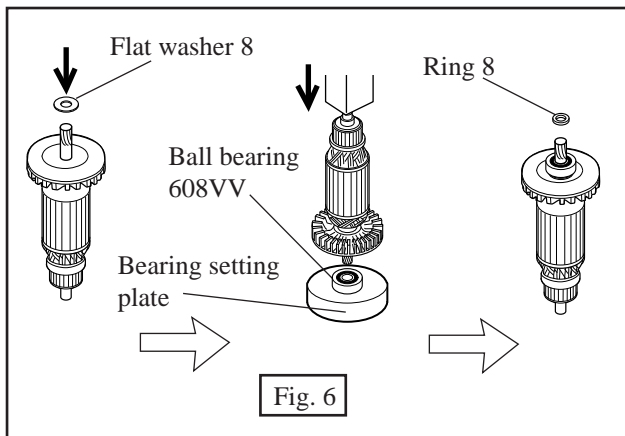

Fig. 6

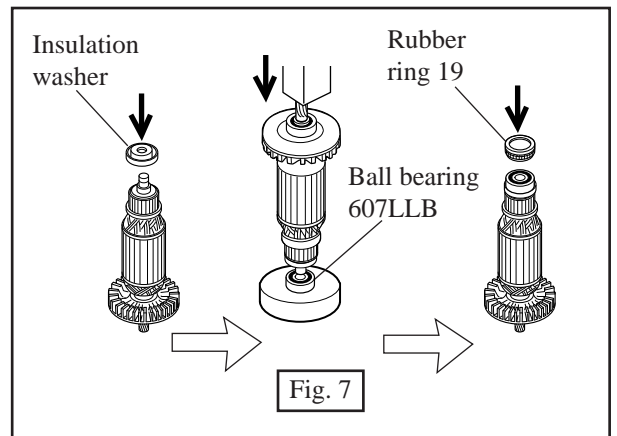

Fig. 7

- (3) Mount the armature to gear housing cover. See Fig. 8.
- (4) Model 6824N: Mount the gear housing cover to gear housing. And fasten it with 3 pcs. of tapping screw 4x25. See Fig. 9.

Model 6824NTP: Fasten grounding wire's terminal to gear housing cover with pan head screw M4x8.

Mount the gear housing cover to gear housing. And fasten it with 3 pcs. of tapping screw 4x25. See Fig.9A.

- (5) Mount carbon brushes. And then, mount handle cover. Fasten it with 3 pcs. of tapping screws 4x25. See Fig. 10.

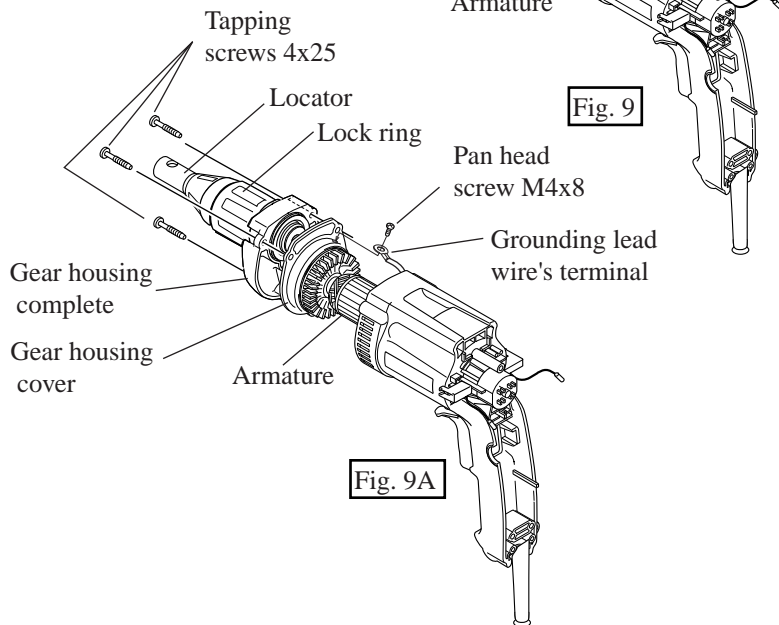
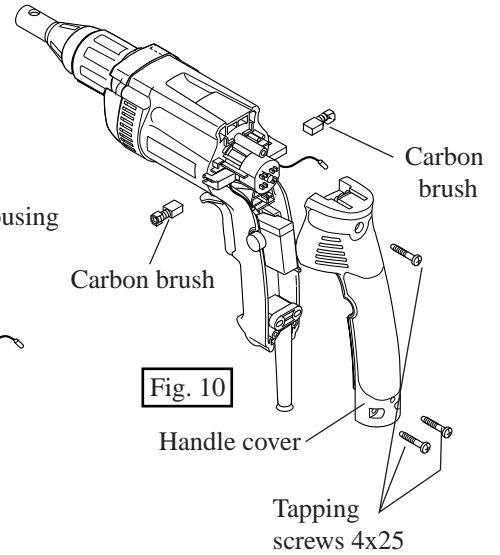
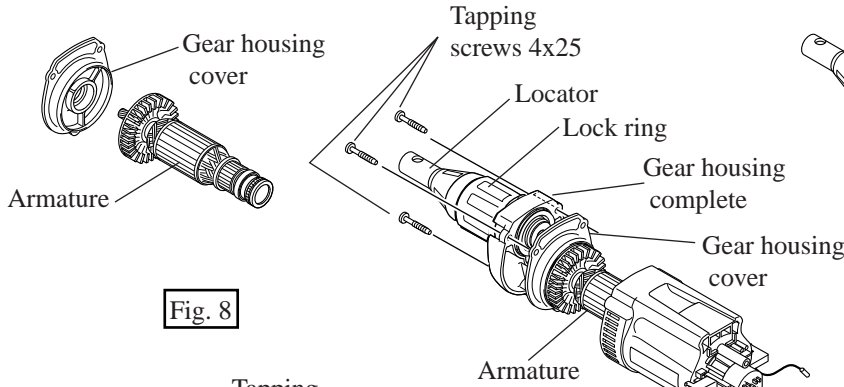

< 4 > Removing clutch section

- (1) Remove locator and lock ring from gear housing. And remove gear housing complete by unscrewing 3 pcs. of tapping screws 4x25. See Fig. 11.
- (2) Separate clutch section by pushing it from locator side to motor side. And take off ring 20. See Fig. 12. Clutch section can be disassembled as illustrated in Fig. 12A.

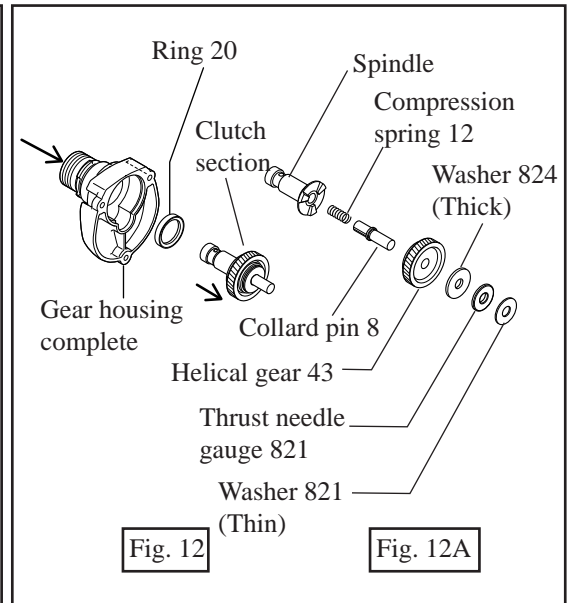
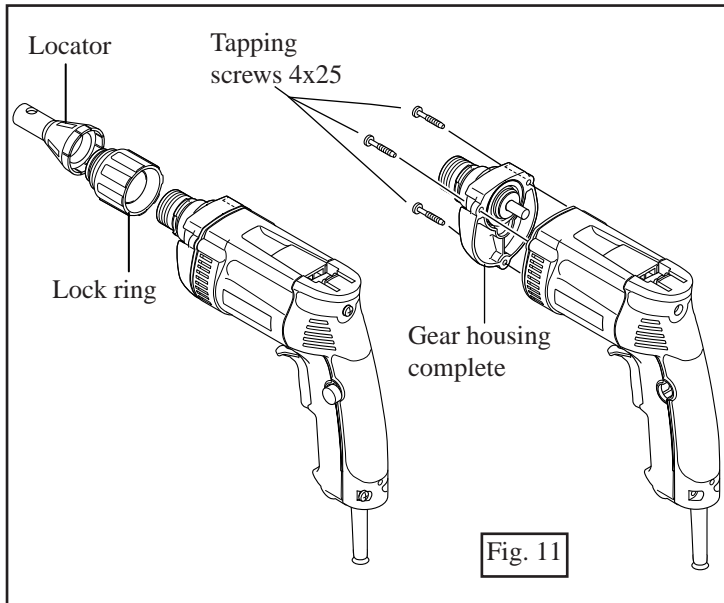

< 5 > Mounting clutch section

- (1) Mount the parts to spindle in the order of compression spring 12, collared pin 8, helical gear 43, washer 824 (thick one), thrust needle gauge 821, and washer 821 (thin one). See Fig. 12A.
- (2) Mount ring 20 and the assembled clutch section to gear housing complete. See Fig. 13.
- (3) Mount gear housing complete to motor housing, and fasten it with tapping screws 4x24. See Fig. 14. And then, mount lock ring and locator to gear housing complete. Refer to Fig. 11.

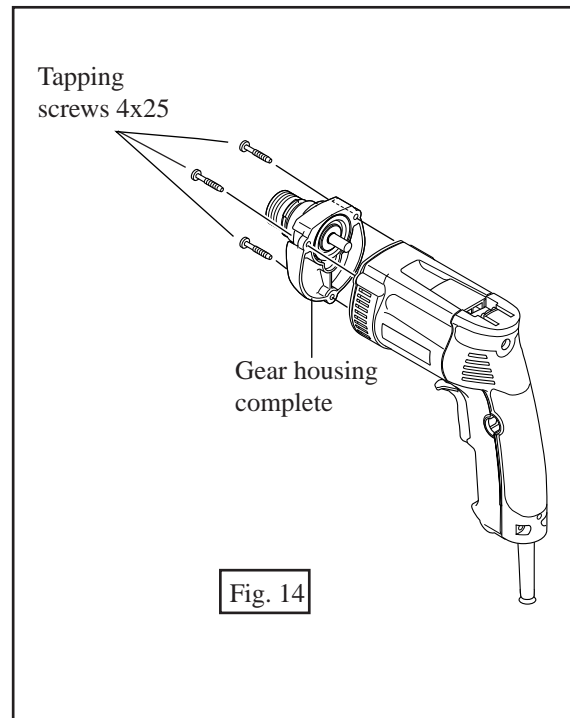
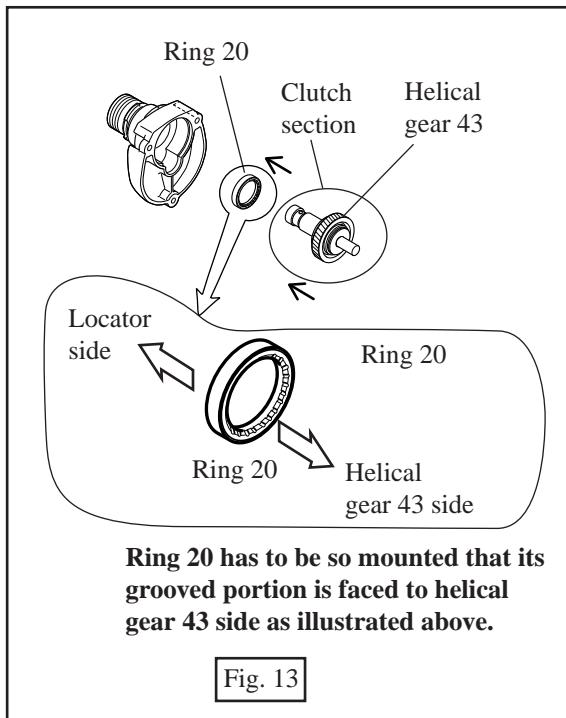

Repair

< 6 > Replacing carbon brush

- (1) Remove handle cover by unscrewing 3 pcs. of tapping screws 4x25. And then, take off carbon brushes. See Fig. 1 at page 2.
- (2) Make sure that brush holders have been mounted to motor housing correctly as illustrated in Fig. 15. If brush holders are mounted as illustrated in Fig. 15A, correct with your finger to mount properly.

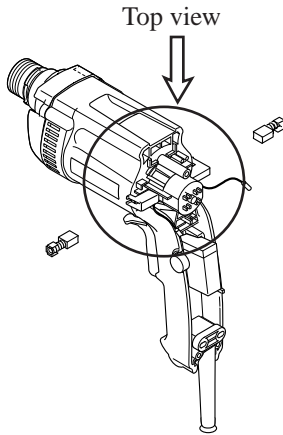

Top view of motor housing and brush holders



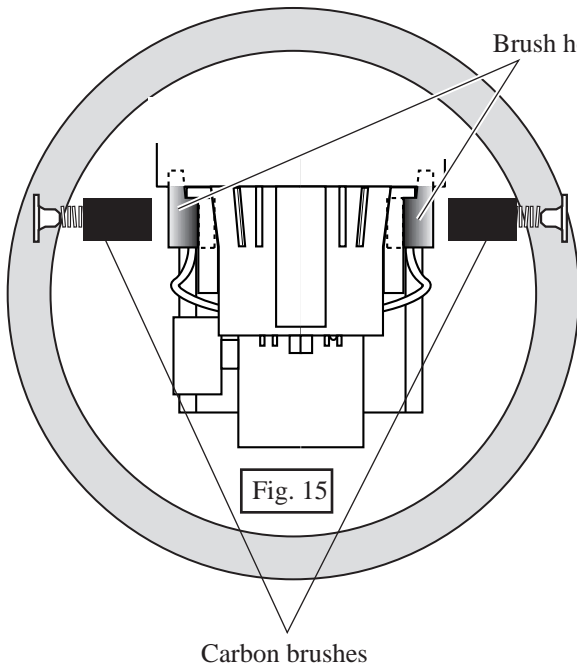

Correct

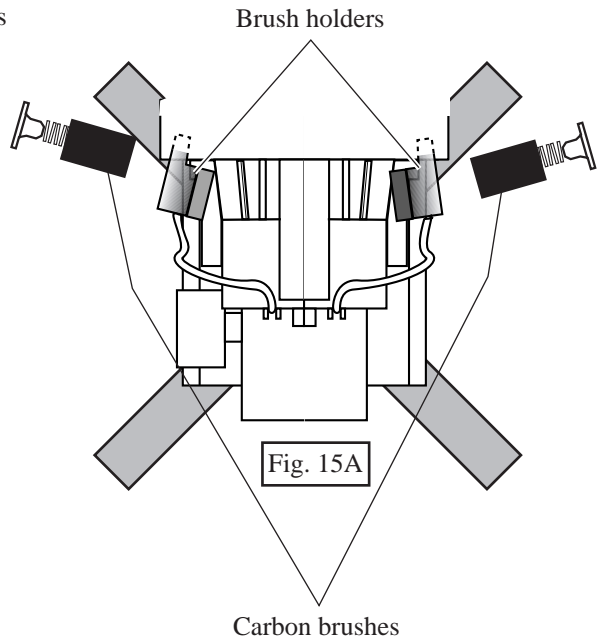

Wrong



► **Circuit diagram**

Color index of lead wires	
Black	
White	
Orange	
Purple	
Green	