

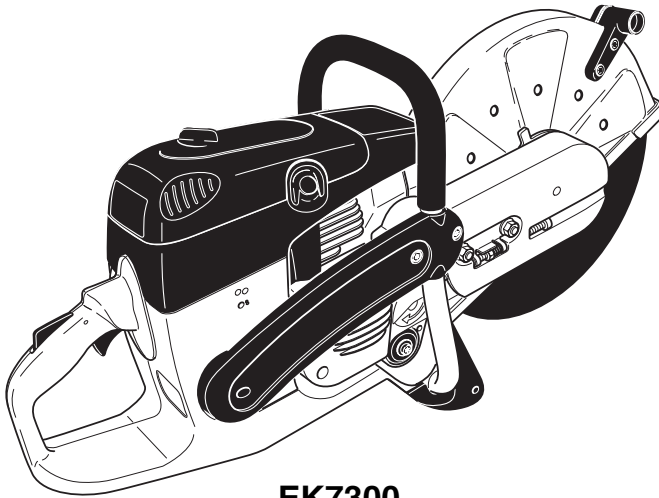

# Instruction Manual

Original Instruction Manual



**EK7300**  
**EK7301**  
**EK8100**



**Important:**

Read this instruction manual carefully before putting the Power Cut into operation and strictly observe the safety regulations!

Keep this instruction manual!

## Thank you for purchasing a MAKITA product!

Congratulations on choosing a MAKITA Power Cut cutoff saw! We are confident that you will be satisfied with this modern piece of equipment. Like our chain saws, the MAKITA Power Cuts feature specially designed high-performance engines with outstanding power-to-weight ratios, for heavy-duty yet lightweight tools.

Other advantages of the MAKITA Power Cuts:

- Sturdy construction and high reliability.
- Maintenance-free electronic ignition, hermetically sealed to protect against dust and moisture.
- Vibration damping with the MAKITA 2-mass system (D2M) for tireless working even when guiding the Power Cut by hand.
- Five-stage air-filter system for reliable working even under very dusty conditions.
- Two options for mounting the cutter attachment: Either centrally, for good balance when guiding the unit manually, or on the side, for flush cuts along walls or curbsides or horizontally directly above the ground.
- Extensive range of resin-bonded and diamond grit cutting discs, trolley with dust catcher, and systems for supplying water to the disc.

The following industrial property rights apply: DE 20013210, DE 19737657, DE 20301182, DE 102006056924, DE 102009014688, DE 202011000529, DE 202011000531, DE 202011000534, US 5709594.

We want you to be satisfied with your MAKITA product.

In order to guarantee the optimal function and performance of your Power Cut and to ensure your personal safety we would request you to perform the following:

**Read this instruction manual carefully before putting the Power Cut into operation for the first time, and strictly observe the safety regulations! Failure to observe these precautions can lead to severe injury or death!**



### Important information for people with pacemakers

During operation, this device emits a weak electromagnetic field. We cannot guarantee that this will not have an influence on heart pacemakers.

To prevent malfunctions and associated health risks, before using this tool you should consult the pacemaker manufacturer or your physician.

Table of contents	Page
<b>Packing</b> .....	2
<b>Delivery inventory</b> .....	3
<b>Symbols</b> .....	3
<b>SAFETY PRECAUTIONS</b>	
Intended use .....	4
General precautions .....	4
Protective equipment .....	4-5
Fuels / Refuelling .....	5
Putting into operation .....	5
Cutting discs .....	6
Kickback and lock-in .....	7
Working behavior / Method of working .....	7
Always observe the following when using synthetic resin cutting discs .....	8
Cutting metal .....	8
Cutting masonry and concrete .....	8-9
Transport and storage .....	9
Maintenance .....	10
First aid .....	10
Disposal and environmental protection .....	10
<b>Technical data</b> .....	11
<b>Denomination of components</b> .....	12
<b>PUTTING INTO OPERATION</b>	
Mounting the cutting disc .....	13
Tightening the V-belt / Checking V-belt tension .....	14
Fuels / Refuelling .....	14-15
Starting the engine .....	16
Cold-starting .....	17
Warm-starting .....	17
Stop engine .....	17
<b>Adjusting the carburetor</b> .....	18
<b>MAINTENANCE</b>	
Changing the V-belt .....	19
Cleaning the protection hood .....	20
Cleaning / changing the air filter .....	20-21
Replacing the spark plug .....	22
Replacing the suction head .....	22
Replacing the starter cable .....	23
Replacing the return spring .....	24
Replacing / cleaning the spark arrester screen .....	26
Instructions for periodic maintenance .....	28
<b>Cutting attachment in central / side position</b> .....	25
Repositioning the cutting attachment .....	25-26
<b>SPECIAL ACCESSORIES</b>	
Diamond cutting discs, trolley, water tank and pressure water system.....	27
<b>Service, spare parts and guarantee</b> .....	28
<b>Troubleshooting</b> .....	29
<b>Extract from spare parts list</b> .....	30-31
Accessories .....	31
<b>EU Conformity Declaration</b> .....	31

### Packing

Your MAKITA Power Cut is packed in a cardboard box to prevent shipping damage.

Cardboard is a basic raw material and is consequently reusable or suitable for recycling (waste paper recycling).



## Delivery inventory

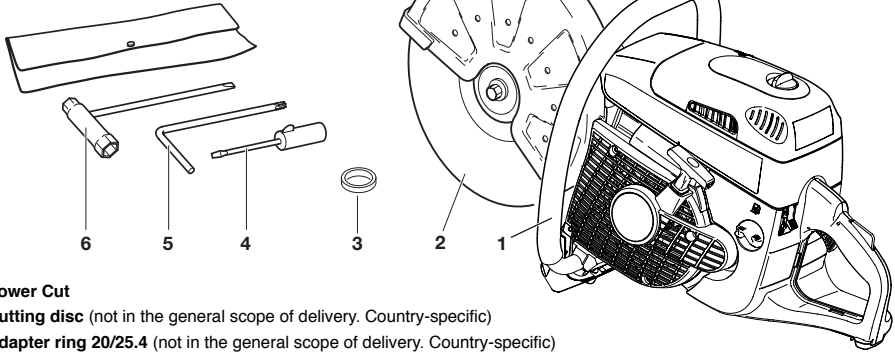

1. Power Cut
2. Cutting disc (not in the general scope of delivery. Country-specific)
3. Adapter ring (not in the general scope of delivery. Country-specific)
4. Screwdriver (for carburetor adjustment)
5. Offset screwdriver
6. Universal wrench 13/19
7. Instruction manual (not shown)

In case one of the parts listed should not be included in the delivery inventory, please consult your sales agent.

## Symbols

You will notice the following symbols on the Power Cut and in the Instruction Manual:

	<b>Read instruction manual and follow the warning- and safety precautions!</b>		<b>Never use circular saw blades!</b>
	<b>Particular care and caution!</b>		<b>Never use damaged cutting discs!</b>
	<b>Forbidden!</b>		<b>Combination switch Choke, Start/Stop (I/O)</b>
	<b>Wear helmet and eye, respiratory and hearing protection!</b>		<b>Starting procedure (Press decompression valve, Engine - manual start)</b>
	<b>Wear protective gloves!</b>		<b>Stop engine!</b>
	<b>Wear respiratory protection!</b>		<b>Warning! Kickback!</b>
	<b>Hazardous dust and/or gas emission!</b>		<b>Fuel and oil mixture</b>
	<b>Fire hazard from flying sparks!</b>		<b>First aid</b>
	<b>No smoking!</b>		<b>Recycling</b>
	<b>No open fire!</b>		<b>CE - Marking</b>
	<b>Direction of cutting wheel rotation</b>		
	<b>Warning: the max. peripheral speed of the cutting disc is 80 m/s!</b>		
	<b>Cutting disc dimensions</b>		

# SAFETY PRECAUTIONS

## Intended use

### Power Cut

Use the Power Cut cutoff saw outdoors only, for trimming and cutting suitable materials, using cutting discs rated for this machine.

### Improper use:

Never use the cutoff saw cutting discs for grinding or sanding (using the side of the cutting disc to remove material). The disc can break! Never use the Power Cut with saw blades, cutter blades, brushes etc.

### Unauthorised users:

Persons unfamiliar with the Instruction Manual, children, young people, and persons under the influence of alcohol, drugs or medications must not use the Power Cut.

## General precautions

- **The operator MUST read this instruction manual to ensure safe operation (even if you already have experience in using cutoff saws).** It is important to be familiar with the operation of this particular cutoff saw. Users insufficiently informed will endanger themselves as well as others due to improper handling.
- Let only persons who have experience in using cutoff saws work with this unit. When letting another person use the Power Cut, this instruction manual must be provided along with it.
- First-time operators should ask a specialist to instruct them in working with gasoline-powered cutoff saws.
- Children and persons under 18 years of age must not be allowed to use this Power Cut. Persons over the age of 16 years may, however, use the Power Cut for the purpose of being trained as long as they are under the supervision of a qualified trainer.
- Working with the Power Cut requires high concentration.
- Operate the Power Cut only if you are in good physical condition. If you are tired, your attention will be reduced. Be especially careful at the end of a working day. Perform all work calmly and carefully. The user has to accept liability for others.
- Never work while under the influence of alcohol, drugs, medication or other substances which may impair vision, dexterity or judgement.
- A fire extinguisher must be available in the immediate vicinity when working in easily inflammable vegetation or when it has not rained for a long time (danger of fire).
- Asbestos and other materials that can release toxins may be cut only with the necessary safety precautions and after notification of the proper authorities and under their supervision or that of a person appointed by them.
- The use of dust-reduction devices is urgently recommended (see Accessories, pressure water tank, water tank).

## Protective equipment

- **In order to avoid head, eye, hand or foot injuries as well as to protect your hearing the following protective equipment must be used during operation of the Power Cut:**
- The kind of clothing should be appropriate, i. e. it should be tight-fitting but not be a hindrance. Clothing in which grains of material can accumulate (trousers with cuffs, jackets and trousers with wide-open pockets, etc.) must not be worn, particularly when cutting metal.
- Do not wear any jewellery or clothing that can get caught or distract from the operation of the Power Cut.
- It is necessary to wear a protective helmet whenever working with the Power Cut. The **protective helmet (A)** is to be checked in regular intervals for damage and is to be replaced after 5 years at the latest. Use only approved protective helmets.
- The helmet **visor (B)** protects the face from dust and material grains. In order to prevent injuries to eyes and face, always

wear **protective goggles (C)** or visor when using the Power Cut.

- To prevent hearing damage, always wear suitable personal **hearing protection**. (ear muffs (D), ear plugs, etc.). Octave brand analysis upon request.
- When dry-cutting dust-producing materials such as stone or concrete, always wear approved **respiratory protection (E)**.
- **Work gloves (F)** of tough leather are part of the required work kit of the Power Cut and must always be worn when working with the Power Cut.

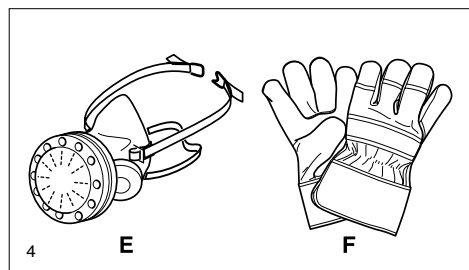
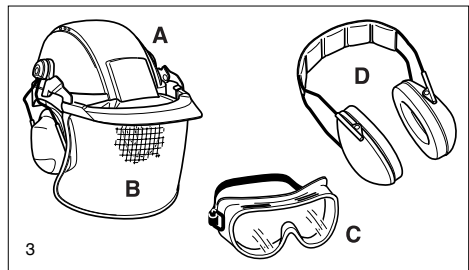
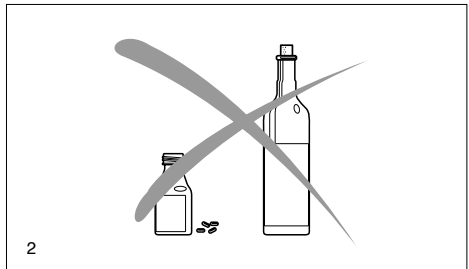
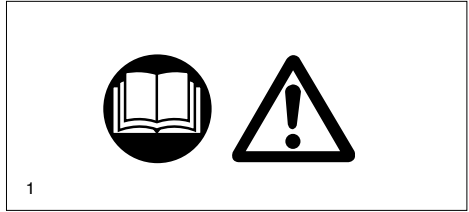

- Always wear **safety shoes or boots** (G) with steel toes, non-skid soles, and leg protectors when working with the Power Cut. Safety shoes equipped with a protective layer provide protection against cuts and ensure a secure footing.
- Always wear a **work suit** (H) of tough material with sufficient flame-retardant qualities whenever working with the cutoff saw.

### Fuels / Refuelling

- Go to a safe, level place before refuelling. **Never refuel while on scaffolding, on heaps of material, or in similar places!**
- Switch off the engine before refuelling the Power Cut.
- Do not smoke or work near open fires (6).
- Let the engine cool down before refuelling.
- Fuels can contain substances similar to solvents. Eyes and skin should not come in contact with mineral oil products. Always wear protective gloves when refuelling (not the regular work gloves!). Frequently clean and change protective clothes. Do not breathe in fuel vapors. Inhalation of fuel vapours can be hazardous to your health.
- Do not spill fuel. If a spill occurs, clean off the Power Cut immediately. Fuel should not come in contact with clothes. If your clothes have come in contact with fuel, change them at once.
- Ensure that no fuel oozes into the soil (environmental protection). Use an appropriate base.
- Refuelling is not allowed in closed rooms. Fuel vapors will accumulate near the floor (explosion hazard).
- Ensure to firmly tighten the screw cap of the fuel tank.
- Before starting the engine, move to a location at least 3 meters (approx. 3 1/4 yards) from where you fuelled the Power Cut (7), but not within the extended swing range of the cutting disc (direction of sparks).
- Fuel cannot be stored for an unlimited period of time. Buy only as much as will be consumed in the near future.
- When making up the gasoline/oil mixture, always put the oil in the mixing container first, and then the gasoline.
- Use only approved and marked containers for the transport and storage of fuel.
- **Keep fuel away from children!**

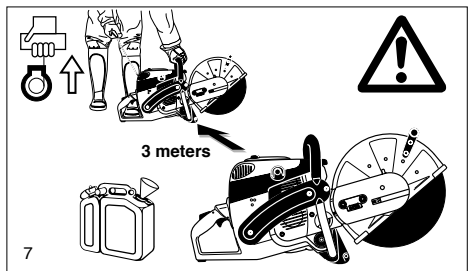
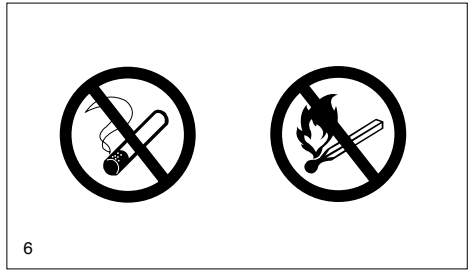
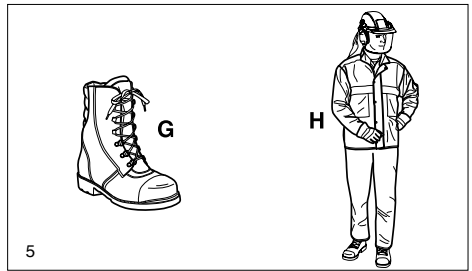

### Putting into operation

- **Do not work on your own. There must be someone around in case of an emergency (within shouting distance).**
- Observe all anti-noise regulations when working in residential areas.
- **Never use the Power Cut near inflammable materials or explosive gases! The Power Cut can create sparks leading to fire or explosion!**
- Make sure that all persons within 30 meters (33 yards), such as other workers, are wearing protective gear (see "Protective Equipment") (8). Children and other unauthorized persons must remain more than 30 meters away from the working area. Keep an eye out for animals as well (9).
- **Before starting work the Power Cut must be checked for perfect function and operating safety according to the prescriptions.** In particular, make sure that the cutting wheel is in good condition (replace immediately if torn, damaged or bent), the cutting wheel is properly mounted, the protective hood is locked in place, the hand guard is properly mounted, the V-belt has the proper tension, the throttle moves easily and the half-throttle lock button functions properly, the grips are clean and dry, and the combination switch functions properly (Start/Stop (I/O) switch, choke).
- Start the Power Cut only after complete assembly and inspection. Never use the Power Cut when it is not completely assembled.

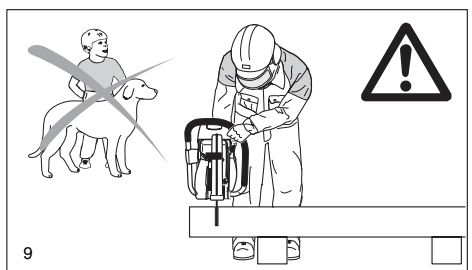
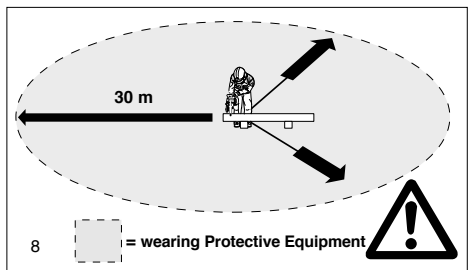

## Cutoff discs

- **The protection hood must always be on! Change discs only with the engine off!**
- There are two basic types of cutoff discs:
  - For metal (hot cutting)
  - For masonry (cold cutting)

### NOTE:

When using diamond cutoff discs, always make sure to observe the "direction of rotation" markings. Diamond discs should only be used for cutting masonry/brick/ concrete etc.

- Cutoff discs are intended only for radial loading, i.e. for cutting. Do not grind with the sides of the cutting disc! This will break the disc (10)!

### Caution!

**Never change direction (turning radius less than 5 meters / 5 1/2 yards), exert lateral (sideways) pressure, or tip the Power Cut during cutting (11)!**

- Use a cutting disc only for cutting the materials it is intended for. The proper type of disc must be used, for either metals or masonry.
- The arbor hole of the cutting disc must be an exact fit with the arbor or shaft. If the arbor hole is larger, it must be fitted with an adapter ring (available as an accessory).
- The cutting disc must be rated for freehand cutting at up to 3850 rpm or 80 m/sec for 400 mm discs, 4370 rpm or 80 m/sec for 350 mm discs, or up to 5100 rpm or 80 m/s for 300 mm discs. Use only cutting discs that comply with EN 12413, EN 13236.
- The disc must be free of defects (12). Do not use defective cutting discs.

**Always tighten the cutting disc mounting bolt to a torque of 30 Nm. Otherwise, the cutting disc can twist.**

- Before starting the cutting disc, make sure you have a steady footing.
- Put the Power Cut into operation only as described in this instruction manual (13). Always place your left foot in the rear handle and grasp the other handle firmly (with thumb and fingers). Other starting methods are not allowed.
- When starting the Power Cut it must be well supported and securely held. The cutting disc must not be touching anything.
- If the cutting disc is new, test it by running it at least 60 seconds at top speed. When doing this, make sure that no persons or body parts are in the extended swing range of the disc, in case it is defective and flies apart.

**When working with the Power Cut always hold it with both hands.** Take the back handle with the right hand and the tubular handle with the left hand. Hold the handles tightly with your thumbs facing your fingers.

- **CAUTION: When you release the throttle lever the disc will keep spinning for a short period of time (free-wheeling effect).**
- Continuously ensure that you have a safe footing.
- Hold the Power Cut such that you will not breathe in the exhaust gas. Do not work in closed rooms or in deep holes or ditches (danger of poisoning by fumes).
- **Switch off the Power Cut immediately if you observe any changes in its operating behavior.**

**Switch off the engine before inspecting the V-belt tension or tightening it, replacing the cutting wheel, repositioning the cutter attachment (side or middle position) or eliminating faults (14).**

- Turn off the engine immediately and check the disc if you hear or feel any change in cutting behaviour.
- Turn off the Power Cut when taking a break or stopping work (14). Place the unit in such a way that the disc is not touching anything and cannot endanger anyone.
- Do not put the overheated Power Cut in dry grass or on any inflammable objects. The muffler is very hot (danger of fire).
- **IMPORTANT:** After wet cutting, first turn off the water feed and then let the disc run at least 30 seconds, to fling off the remaining water and prevent corrosion.

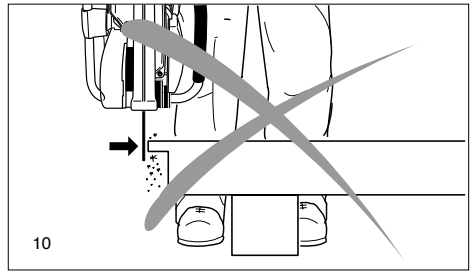

10

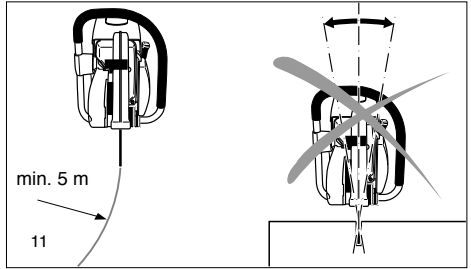

11

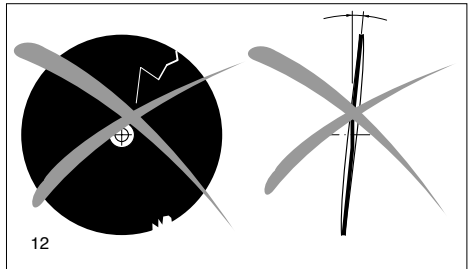

12

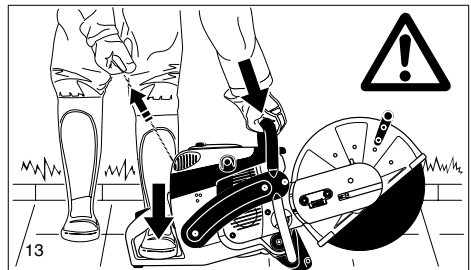

13

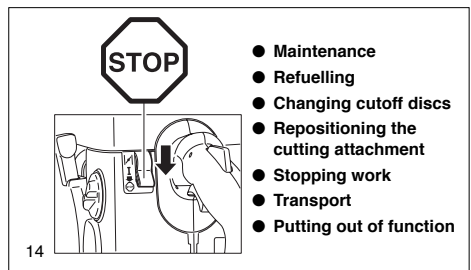

14

## Kickback and lock-in

- When working with the Power Cut there is a danger of kickback and lock-in.
- Kickback occurs when the top of the cutting disc is used for cutting (15).
- This causes the Power Cut to be thrown back toward the user with great force and out of control. **Risk of injury!**

**To prevent kickback, observe the following:**

- Never cut with the section of the cutting disc shown in figure 15.
- **Be especially careful when reinserting the disc into cuts that have already been started!**
- Lock-in occurs when the cut narrows (crack, or workpiece under stress).
- This causes the Power Cut to suddenly jump forward, out of control and with great force. **Risk of injury!**

**To prevent lock-in, observe the following:**

- When reinserting the disc into previous cuts, have the Power Cut running at top speed. Always cut at top speed.
- Always support the workpiece so that the cut is under tension (16), so that the cut does not press together and jam the cutting disc as it proceeds through the material.
- When starting a cut, apply the disc to the workpiece with care. Do not just shove it into the material.
- Never cut more than one piece at a time! When cutting, make sure that no other workpiece comes into contact.

## Working behavior / Method of working

- Before starting work, check the work area for any hazards (electrical wires, inflammable substances). Clearly mark the work area (for example with warning signs or by cordoning off the area).
- When working with the Power Cut hold it firmly by the front and rear handles. Never leave the Power Cut unattended!
- Use the Power Cut at high speed as far as possible (see "Technical Data").
- Only use the Power Cut during good light and visibility periods. Be aware of slippery or wet areas, and of ice and snow (risk of slipping).
- Never work on unstable surfaces. Make sure that there are no obstacles in the working area, risk of stumbling. Always ensure that you have a safe footing.
- Never cut above your shoulder height (17).
- Never stand on a ladder to cut (17).
- Never use the Power Cut while standing on scaffolding.
- Do not lean over too far when working. When putting down and picking up the Power Cut, do not bend over from the waist, but instead bend in the knees. Save your back!
- Guide the Power Cut in such a way that no part of your body is within the extended swing range of the disc (18).
- Use cutting discs only for the materials for which they are designed!
- Use cutting discs only for the materials for which they are designed. Do not use the Power Cut to lift up and shovel away pieces of material and other objects.

**Important!** Before cutting, remove all foreign objects, such as rocks, gravel, nails etc. from the cutting area. Otherwise, such objects can be flung away by the disc with great speed. **Injury hazard!**

- When cutting workpieces down to length use a firm support. If necessary, secure the workpiece from slipping, but do not steady it with your foot or allow another person to hold it.
- When cutting round items, always secure them against rotation.
- When guiding the Power Cut by hand, use the side mounting position of the cutter attachment only when actually necessary. Otherwise, always use the central position. This gives the unit a better balance, for reduced operator fatigue.

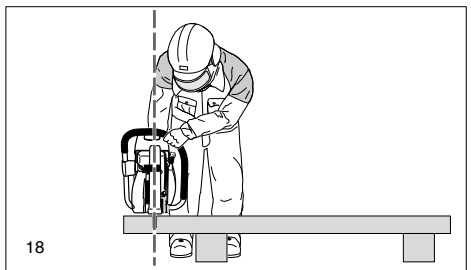
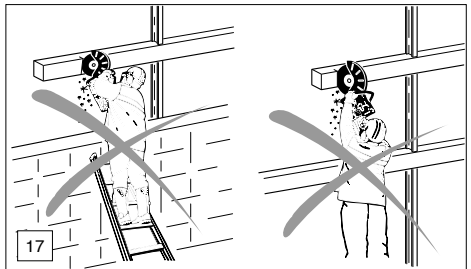
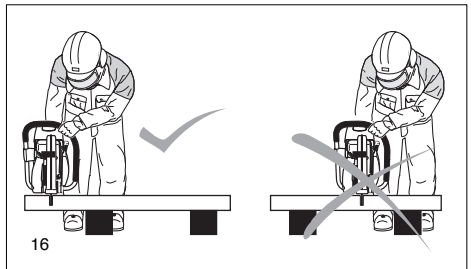

When using synthetic resin cutting discs, always observe the following:

**CAUTION:**

- Synthetic resin cutting discs can absorb moisture. This moisture can cause the disc to become unbalanced at high speed. This imbalance can cause the disc to break.
- Do not cool resin cutting discs with water or other fluids.
- Do not expose resin cutting discs to high humidity or rain!

Do not use resin cutting discs past their use-by date (expiration date)! The date (quarter and year) is stamped on the disc's arbor ring.

**EXAMPLE: 04 / 2015**

This cutting disc can be used through the end of the fourth quarter of 2015, if properly stored and correctly used.

**Cutting metals**

**IMPORTANT!**

**Always wear approved respiratory protection!**

Materials that can release toxic substances may be cut only after notifying the proper authorities and under their supervision or that of a person appointed by them.

**CAUTION!**

The rapid rotation of the cutting disc heats metal and melts it at the point of contact. Swing the guard as far down as possible (19) in order to direct the stream of sparks forward, away from the operator (fire hazard).

- Determine the cut line, mark the cut and apply the disc to the material at moderate speed, to cut a guide groove before going to top speed and applying more pressure to the Power Cut.
- Keep the disc straight and vertical. Do not tip it, as this can break it.
- The best way to get a good, clean cut is to pull or move the Power Cut back and forth. Do not simply press the disc into the material.
- Thick round stock is best cut in stages (20).
- Thin tubing and pipes can be cut with a simple downward cut.
- Cut large-diameter pipes as for round stock. To prevent tipping and for better control, do not let the disc sink too deeply into the material. Instead, always cut shallow around the whole piece.
- Worn discs have a smaller diameter than new discs, so that at the same engine speed they have a lower effective circumferential speed and therefore do not cut as well.
- Cut I-beams and L-bars in steps; see Figure 21.
- Cut bands and plates like pipes: along the wide side with a long cut.
- When cutting material under stress (supported material or material in structures), always make a notch in the thrust (pressure) side, and then cut from the tension side, so that the disc does not lock in. **Secure cutoff material from falling!**

**CAUTION!**

If there is a chance that the material is under stress, be prepared for it to kick back. Make sure you can get out of the way if you have to!

Be particularly careful in scrap-metal yards, junkyards, at accident sites, and with haphazard piles of material. Precariously balanced pieces or pieces under stress can act in unpredictable ways, and may slide, jump out, or burst. Secure cutoff material from falling! Always exercise extreme caution and use only equipment that is in perfect working order.

Observe the accident-prevention rules and regulations of your employer and/or insurance organization.

**Cutting masonry and concrete**

**IMPORTANT!**

**Always wear approved respiratory protection!**

Asbestos and other materials that can release toxic substances may be cut only after notifying the proper authorities and under their supervision or that of a person appointed by them. When cutting prestressed and reinforced concrete piles, follow the instructions and standards of the responsible authorities or the builder of the structural member. Reinforcement rods must be cut in the prescribed sequence and in accordance with applicable safety regulations.

**NOTE:**

Mortar, stone, and concrete develop large quantities of dust during cutting. To increase the lifetime of the cutting disc (by cooling), to improve visibility, and to avoid excessive dust creation, we strongly recommend wet cutting instead of dry cutting.

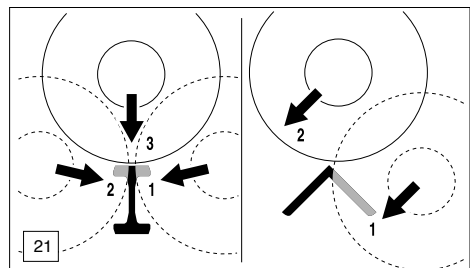
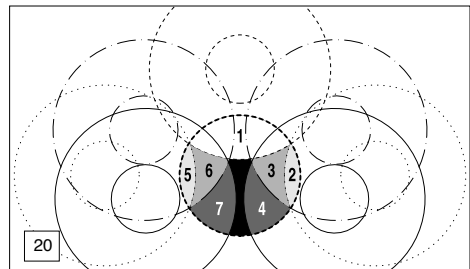
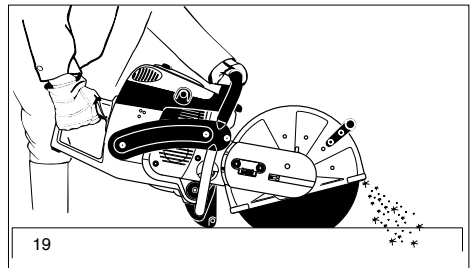



In wet cutting, the disc is wetted at an equal rate on both sides by a trickle of water. MAKITA offers the right accessories for all wet cutting applications (see also "SPECIAL ACCESSORIES").

- Remove foreign objects such as sand, stones and nails found within the working area. **Caution: Watch out for electric wires and cables!**

**The rapid rotation of the cutting disc at the point of contact throws fragments out of the cut groove at high speed. For your safety, swing the protection hood down as far as possible (23), so that material fragments are thrown forward, away from the operator.**

- Mark the cut, and then make a groove about 5 mm (just under 1/5") along the entire length of the planned cut. This groove will then guide the Power Cut accurately during the actual cutoff.

**NOTE:**

For long, straight cuts we recommend using a trolley (24, see also "SPECIAL ACCESSORIES"). This makes it much easier to guide the unit straight.

- Perform the cut with a steady back-and-forth motion.
- When cutting slabs to size, you need not cut through the entire material thickness (creating unnecessary dust). Instead, simply make a shallow groove, and then knock off the excess material cleanly on a flat surface (25).

**CAREFUL!**

When cutting into lengths, cutting through material, making cutouts, etc., always make sure to plan the direction and sequence of cuts in such a way that the disc does not get jammed by the cut-off piece, and that no persons can be injured by falling pieces.

**Transport and storage**

- **Always turn off the Power Cut when transporting it or moving it from place to place on a site (26).**
- **Never carry or move the unit with the engine on or the disc moving!**
- Carry the unit only by the tubular (middle) handle with the cutting disc pointing behind you (26). Avoid touching the exhaust muffler (burn hazard!)
- When moving the Power Cut over longer distances, use a wheelbarrow or wagon.
- When transporting the Power Cut in a vehicle, make sure it is securely positioned in such a way that no fuel can leak out. Always remove the cutting disc before transporting the unit in a vehicle.
- The Power Cut should be stored safely in a dry place. It must not be left outdoors! Always dismount the cutting disc before storage. Keep the Power Cut away from children.
- **Before long-term storage and before shipping the Power Cut, follow the instructions in the chapter on "Periodic care and maintenance". ALWAYS empty the fuel tank and run the carburetor dry.**
- When putting cutting discs in storage, be careful to:
  - Clean and dry them well. **CAUTION: Do NOT clean synthetic resin cutting discs with water or other fluids!**
  - Store them lying down flat.
  - Avoid dampness, freezing temperatures, direct sunshine, high temperatures and temperature fluctuations, as these can cause breakage and splintering.
  - Before re-using a resin cutting disc, make sure of the use-by (expiration) date (quarter and year, stamped on the arbor ring). If this date has been exceeded, do **NOT** use the cutting disc.
- **Always check new cutting discs or cutting discs that have been in storage to make sure that they are free of defects and before the first cut test-run the tool at top speed for at least 60 seconds. Keep body parts and people well away out of range of the direction of the cutting disc during this test.**

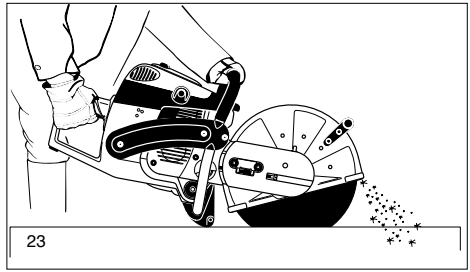

23

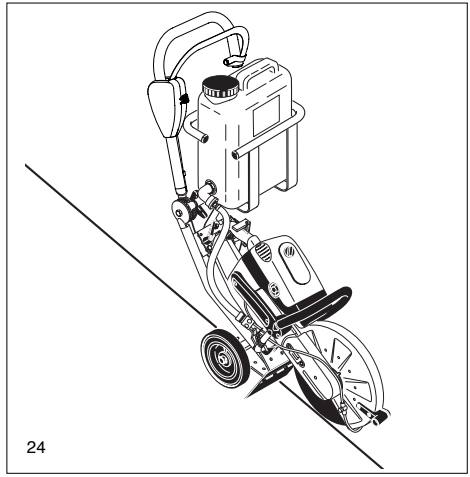

24

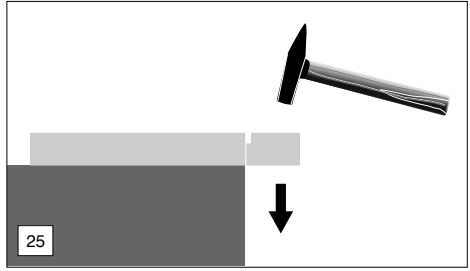

25

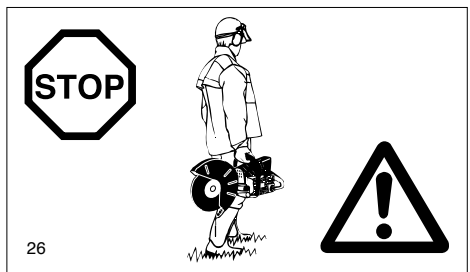

26

## Maintenance

- **Before performing maintenance work switch off the Power Cut (27) and pull out the plug cap.**
- Always check the Power Cut before using it to make sure that it is in good working order. In particular, make sure that the cutting disc is properly mounted. Make sure that the cutting wheel is undamaged and suitable for the job it will be used for.
- Operate the Power Cut only at a low noise and emission level. For this ensure the carburetor is adjusted correctly.
- Clean the Power Cut regularly.
- Check the fuel tank cap regularly for good sealing.

**Observe the accident prevention instructions issued by trade associations and insurance companies. NEVER make any modifications to the Power Cut! You will only be putting your own safety at risk!**

Perform only the maintenance and repair works described in the instruction manual. All other work must be carried out by MAKITA Service.

Use only original MAKITA spares and accessories.

The use of non-MAKITA spares, accessories, or cutting discs increases the risk of accident. We cannot accept any responsibility for accidents or damage occurring in association with the use of cutting discs or accessories other than original MAKITA.

## First aid

For the event of a possible accident, please make sure that a first aid kit is always immediately available close by. Immediately replace any items used from the first aid box.

**When calling for help, give the following information:**

- Place of the accident
- What happened
- Number of injured people
- Kind of injuries
- Your name!

## NOTE

Individuals with poor circulation who are exposed to excessive vibration may experience injury to blood vessels or the nervous system.

Vibration may cause the following symptoms to occur in the fingers, hands or wrists: "Falling asleep" (numbness), tingling, pain, stabbing sensation, alteration of skin colour or of the skin. **If any of these symptoms occur, see a physician!**

## Disposal and environmental protection

Be mindful of the environment!

Dispose of worn-out or defective cutting discs in accordance with your local disposal regulations. To protect unusable cutting discs from misuse, destroy them before disposal.

When the Power Cut is worn out or damaged beyond repair, have it disposed of or recycled in an environmentally sound manner. If necessary, consult your local authorities.

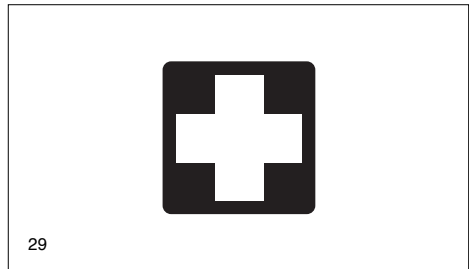
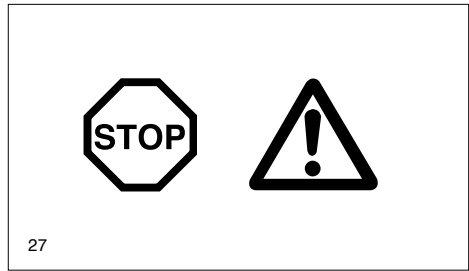

## Technical data

		EK7300	EK7301
Displacement	cm <sup>3</sup>	73	
Bore	mm	50	
Stroke	mm	37	
Max. power / operating speed	kW/1/min	3.8 / 9.150	
Max. torque	Nm	4.3	
Idling speed	1/min	2.500	
Clutch engagement speed	1/min	3.800	
Engine speed limitation	1/min	9.400 ± 145	
Max. spindle speed	1/min	4.300	
Sound pressure level L <sub>PA,eq</sub> per EN 19432 <sup>1) 4) 5)</sup>	dB(A)	99,6 / K <sub>PA</sub> =2,5	
Sound power level L <sub>WA,eq</sub> per EN 19432 <sup>1) 6)</sup>	dB(A)	109,0 / K <sub>WA</sub> =2,5	
Vibration acceleration a <sub>HV,eq</sub> per EN 19432 <sup>1) 6)</sup>			
- Tubular handle	m/s <sup>2</sup>	7,0 / K=2	
- Rear handle	m/s <sup>2</sup>	4,9 / K=2	
Carburetor (diaphragm carburetor)	Type	WALBRO WJ-126 / WJ-131	
Ignition system (with speed limitation)	Type	electronic	
Spark plug	Type	NGK BPMR 7A / BOSCH WSR 6F / CHAMPION RCJ 6Y	
Electrode gap	mm	0.5	
Fuel consumption at max. load per ISO 8893	kg/h	1.7	
Specific consumption at max. load per ISO 8893	g/kWh	450	
Fuel tank capacity	cm <sup>3</sup>	1.100	
Mixture ratio (fuel/two-stroke oil)			
- when using MAKITA oil		50:1	
- when using other oils (quality grade: JASO FC or ISO EGD)		50:1	
- when using Aspen Alkylat (two-stroke fuel)		50:1 (2%)	
Cutting disc for 80 m/sec. <sup>2)</sup>	mm	300 / 20.0 / 5 <sup>3)</sup>	350 / 20.0 / 5 <sup>3)</sup>
Cutting disc for 80 m/sec. <sup>2) 5)</sup>	mm	---	350 / 25.4 / 5 <sup>3)</sup>
Arbor diameter	mm	20.0	20.0 (25.4) <sup>5)</sup>
V-belt	no.	965 300 470	
Overall weight (tanks empty, without cutting disc)	kg	9.8	10

		EK8100	
Displacement	cm <sup>3</sup>	81	
Bore	mm	52	
Stroke	mm	38	
Max. power / operating speed	kW/1/min	4,2 / 9.150	
Max. torque	Nm	5,0	
Idling speed	1/min	2.500	
Clutch engagement speed	1/min	3.800	
Engine speed limitation	1/min	9.350 ± 145	
Max. spindle speed	1/min	3.820	
Sound pressure level L <sub>PA,eq</sub> per EN 19432 <sup>1) 4) 6)</sup>	dB(A)	100,3 / K <sub>PA</sub> =2,5	
Sound power level L <sub>WA,eq</sub> per EN 19432 <sup>6) 7)</sup>	dB(A)	109,6 / K <sub>WA</sub> =2,5	
Vibration acceleration a <sub>HV,eq</sub> per EN 19432 <sup>1) 6)</sup>			
- Tubular handle	m/s <sup>2</sup>	7,8 / K=2	
- Rear handle	m/s <sup>2</sup>	6,1 / K=2	
Carburetor (diaphragm carburetor)	Type	WALBRO WJ-126 / WJ-131	
Ignition system (with speed limitation)	Type	electronic	
Spark plug	Type	NGK BPMR 7A / BOSCH WSR 6F / CHAMPION RCJ 6Y	
Electrode gap	mm	0,5	
Fuel consumption at max. load per ISO 8893	kg/h	1,85	
Specific consumption at max. load per ISO 8893	g/kWh	450	
Fuel tank capacity	cm <sup>3</sup>	1.100	
Mixture ratio (fuel/two-stroke oil)			
- when using MAKITA oil		50:1	
- when using other oils (quality grade: JASO FC or ISO EGD)		50:1	
- when using Aspen Alkylat (two-stroke fuel)		50:1 (2%)	
Cutting disc for 80 m/sec. <sup>2)</sup>	mm	400 / 20,0 / 5 <sup>3)</sup>	
Cutting disc for 80 m/sec. <sup>2) 5)</sup>	mm	400 / 25,4 / 5 <sup>3)</sup>	
Arbor diameter	mm	20,0 (25,4) <sup>5)</sup>	
V-belt	no.	965 300 481	
Overall weight (tanks empty, without cutting disc)	kg	10,6	

<sup>1)</sup> Data apply to idle and rated speed operation at a ratio of 1/7 to 6/7. <sup>2)</sup> Circumference speed at max. engine speed.

<sup>3)</sup> Outside diameter / arbor hole / thickness. <sup>4)</sup> At the workplace (at user's ear). <sup>5)</sup> Country-specific. <sup>6)</sup> Uncertainty (K=). <sup>7)</sup> Data apply rated speed operation.

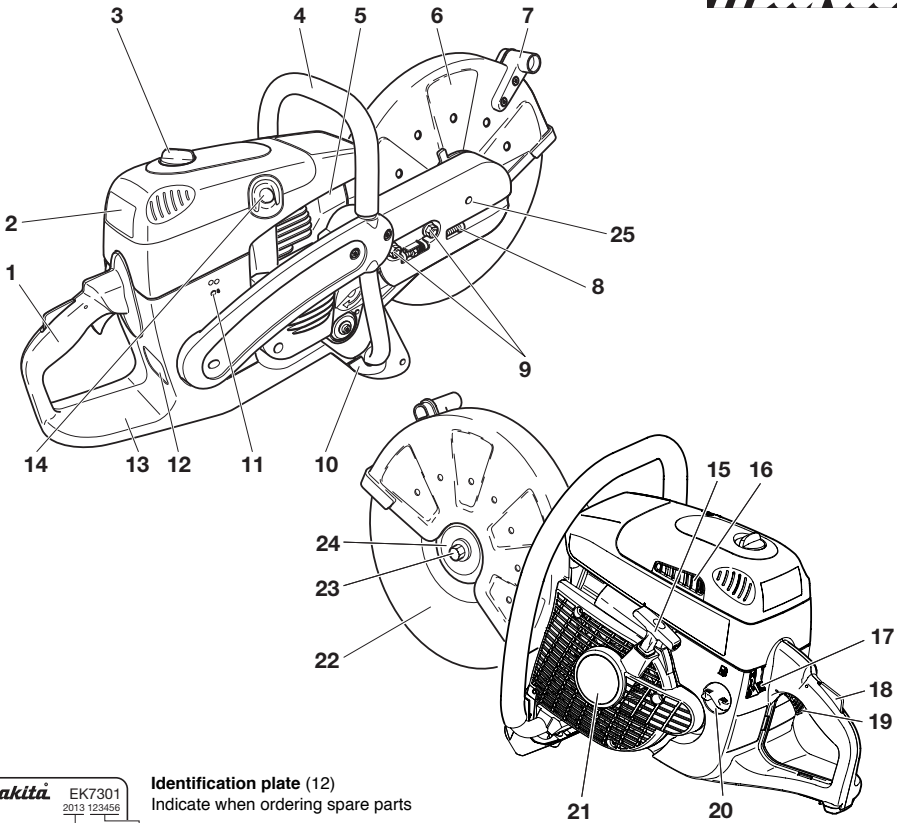

**Identification plate (12)**  
Indicate when ordering spare parts

Serial number  
Year of manufacture

- |    |  |    |  |
|----|--|----|--|
| 1  | Handle   | 14 | Decompression valve                          |
| 2  | Filter cover for air filter and spark plug cap | 15 | Starter grip                                 |
| 3  | Cover lock                                     | 16 | Air intake                                   |
| 4  | Tubular handle                                 | 17 | Combination switch „Choke, Start/Stop (I/O)” |
| 5  | Muffler  | 18 | Safety locking button                        |
| 6  | Protection hood                                | 19 | Throttle lever                               |
| 7  | Grip   | 20 | Tank cap (fuel)                              |
| 8  | V-belt tension adjusting screw                 | 21 | Starter housing with starter                 |
| 9  | Retaining nuts                                 | 22 | Cutting disc                                 |
| 10 | Stand  | 23 | Disc bolt                                    |
| 11 | Carburetor adjustment opening                  | 24 | Spring washer                                |
| 12 | Identification plate                           | 25 | Hold opening                                 |
| 13 | Fuel tank with handle                          |    |  |



## PUTTING INTO OPERATION

### CAUTION:

**Always turn off the engine** and pull off the spark plug cap before doing any work on the Power Cut! Always wear protective gloves!

### CAUTION:

Start the Power Cut only after complete assembly and inspection.

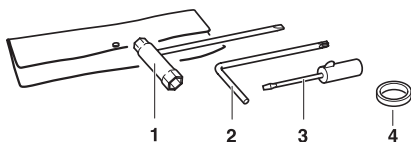

For the the following work, use the assembly tools included with delivery:

1. 13/19 AF combination wrench
2. Allen key
3. Carburetor adjustment screwdriver
4. Adapter ring (not in the general delivery inventory)

Place the Power Cut on a stable surface and carry out the following assembly steps:

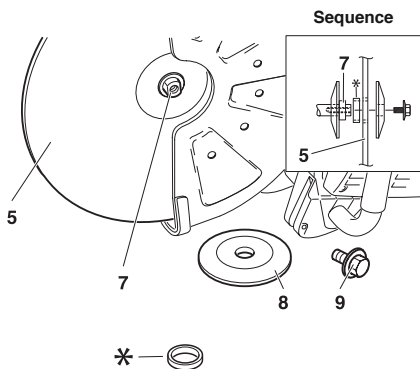

### Mounting the cutting disc

Inspect the disc for damage.



See **SAFETY INSTRUCTIONS**, Page 6.

Unscrew screw (9) and remove the spring washer (8).

Place the cutting disc (5) on the arbour (7).

**CAUTION:** The arbor hole of the cutting disc must be an exact fit with the arbor or shaft. If the arbor hole is larger, it must be fitted with an adapter ring (\*). **Non-compliance can cause serious injury!**



**Make sure the cutting disc is installed so it turns in the right direction, if a direction is marked on the disc.**

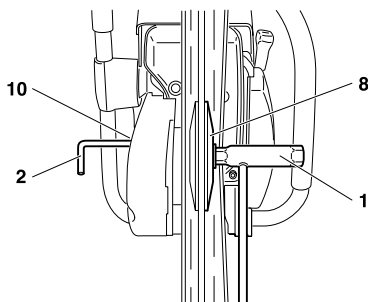

Place the spring washer (8) on the arbour and insert the screw (9) and tighten by hand.

Turn the disc slowly until the stop hole of the V-belt pulley is visible in the cutting arm cover (10).

Insert the Allen key (2) as far as it will go. The shaft is now blocked.

Tighten the screw with the combination wrench (1)

**NOTE:** Tighten the screw firmly ( $30 \pm 2$  Nm), as otherwise the cutting wheel may slip during cutting.

## Tightening the V-belt / Checking V-belt tension

### IMPORTANT:

Exact V-belt tension is essential for maximum cutting performance with minimum fuel consumption. Improper V-belt tension will result in premature wear to the V-belt and V-belt wheel or damage to the clutch bearing.

If the Power Cut is new or the V-belt has been replaced, retighten the V-belt after the first hour of operation!



**NOTE:** The two fastening nuts (11) must be loosened before tightening the V-belt or checking the tension.

To increase the belt tension, turn the tightening screw (12) to the right (clockwise) with the combination wrench included with the Power Cut.

The belt tension is correctly adjusted when the nut (13) is centred on the mark (14).

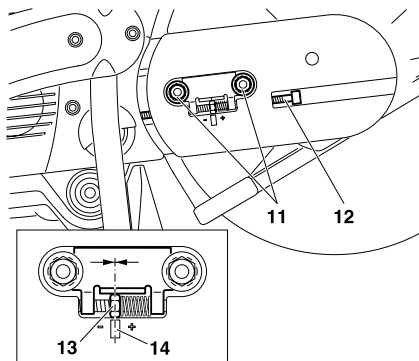

### IMPORTANT:



After tightening/inspection, make certain to tighten the fastening nuts (11) ( $30 \pm 2$  Nm).

## Fuels

### Caution:

This tool uses mineral-oil products (gasoline and oil).

Be especially careful when handling gasoline.

Do not smoke. Keep tool well away from open flames, spark, or fire (explosion hazard).



### Fuel mixture

This tool is powered by a high-performance air-cooled two-stroke engine. It runs on a mixture of gasoline and two-stroke engine oil.

The engine is designed for unleaded regular gasoline with a min. octane value of 91 ROZ. In case no such fuel is available, you can use fuel with a higher octane value. This will not affect the engine.

In order to obtain an optimum engine output and to protect your health and the environment use unleaded fuel only.

To lubricate the engine, use a synthetic oil for two-stroke air-cooled engines (quality grade JASO FC or ISO EGD), which has to be added to the fuel. The engine is designed for the use of MAKITA high-performance two-stroke engine oil at a mixture ratio of only 50:1 to protect the environment. In addition, this ensures a long service life and reliable operation with minimum exhaust emissions.

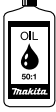
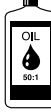
Gasoline	50:1	50:1
		
1000 ml (1 litre)	20 ml	20 ml
5000 ml (5 litre)	100 ml	100 ml
10000 ml (10 litre)	200 ml	200 ml

### The correct mixture ratio:

**50:1** when using MAKITA high-performance two-stroke engine oil, i. e. mix 50 parts gasoline with 1 part oil.

**50:1** When using other synthetic two-stroke engine oils (quality grade JASO FC or ISO EGD), i. e. mix 50 parts gasoline with 1 part oil.

MAKITA high-performance two-stroke engine oil (50:1) is available in the following sizes to suit your individual requirements:

100 ml order number 980 008 606

1 l order number 980 008 607

**NOTE:** For preparing the fuel-oil mixture first mix the entire oil quantity with half of the fuel required, then add the remaining fuel. Shake the finished mixture thoroughly before pouring it into the tank.

**Caution:** Open the tank cap carefully, as pressure might have built up inside!

**It is not wise to add more engine oil than specified to ensure safe operation. This will only result in a higher production of combustion residues which will pollute the environment and clog the exhaust channel in the cylinder as well as the muffler. In addition, fuel consumption will rise and performance will decrease.**

## The Storage of Fuel

Fuels have a limited storage life. Fuel and fuel mixtures age through evaporation, especially at high temperatures. Aged fuel and fuel mixtures can cause starting problems and damage the engine. Purchase only that amount of fuel, which will be consumed over the next few months. At high temperatures, once fuel has been mixed it should be used up in 6-8 weeks.

**Store fuel only in proper containers, in dry, cool, secure locations!**



## AVOID SKIN AND EYE CONTACT

Mineral oil products degrease your skin. If your skin comes in contact with these substances repeatedly and for an extended period of time, it will dry out. Various skin diseases may result. In addition, allergic reactions are known to occur.

Eyes can be irritated by contact with oil. If oil comes into your eyes, immediately wash them with clear water.

If your eyes are still irritated, see a doctor immediately!

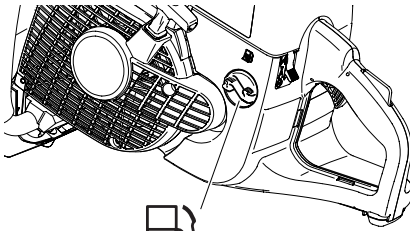

Fuel mixture

## Refuelling

### IMPORTANT:

#### FOLLOW THE SAFETY PRECAUTIONS!

**Be careful and cautious when handling fuels.**

**The engine must be turned off and cooled down!**

Carefully clean the area around the fuel-tank filler neck to keep dirt from getting in the tank.

Place the unit on its side on an even surface.

Unscrew the tank cap and fill tank with fuel mixture. Take care to avoid spilling.

Screw the tank cap back on hand-tight.

**Clean screw cap and tank after refuelling. Never start or operate the Power Cut in the same place as it was fuelled!**

If fuel gets on your clothing, change clothes immediately.

## Starting the engine



necessary

This model is fitted with a semiautomatic decompression valve (1) to make starting easier. Press the rubber cover until you can feel it engage. This pushes in the decompression valve behind it. This in turn reduces the compression, so that it takes less force to pull the starter cord to accelerate the engine to its starting speed.

The high pressure in the combustion chamber after the first ignition automatically closes the decompression valve.

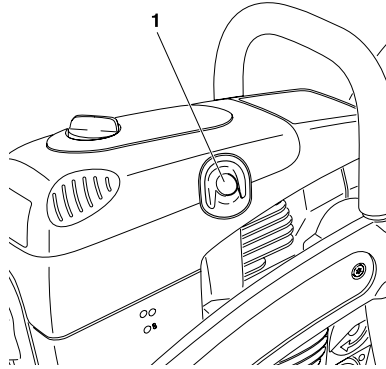

## CAUTION:

Observe the **SAFETY INSTRUCTIONS** on page 4 and 5!

**Start the Power Cut only after complete assembly and inspection!**

**Move at least 3m away from the place where you fuelled the Power Cut.**

**Make sure you have a good footing, and place the Power Cut on the ground in such a way that the cutting disc is not touching anything.**

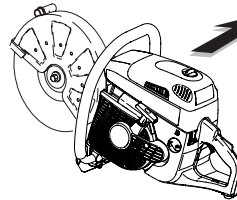
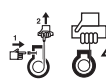

3 meters



Move the protective hood (3) into the proper position for the work you intend to do (see illustration).

Grasp the grip (2). The hood (3) can swing in both ways within its range of motion.

## Caution:

Always make sure that the straight outer edge of the impact plate (4) and the edge of the hood are parallel (see arrows).

If this is not the case, take the tool to a service centre.

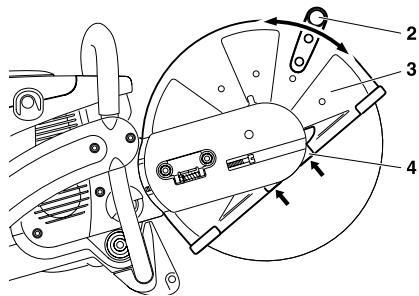



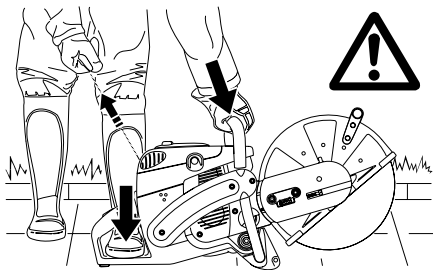

### Cold starting:

Grasp front handle firmly with one hand and press the Power Cut against the ground.

Place left toe in the rear handguard.

Push the combination switch (6) up (choke position). This will automatically activate the half-throttle lock.

**NOTE:** If the Power Cut is mounted on the trolley, do not operate the gas lever (throttle) on the side of the trolley!

Pull the starter cable out slowly until you feel resistance (piston is now just before top dead center).

Press in the decompression valve (5).

**Pull starter cable quickly and firmly, until you hear the first ignition, but to a max. of 3-5 pulls!**

**Important:** Do not pull the starter cable out more than about 50 cm / 20", and guide it back slowly by hand (instead of letting it snap back).

Press in the decompression valve (5).

Move the combination switch (6) to the middle "I" position. Again pull the starter cable quickly and firmly.

As soon as the engine is running, grasp the rear handle (the safety lock switch (8) will be depressed by the palm of your hand) and tap the throttle (9). The half-throttle lock will be disengaged and the engine will run in idle.

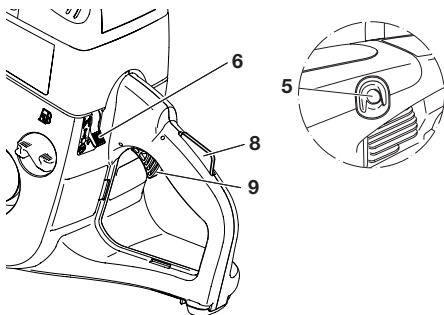

Cold start (Choke)

Warm start

Engine off

### Warm starting:

As described above for cold starting, but before starting push the combination switch (6) up (Choke position) and then right away back to the middle "I" position.

This is only to engage the half-throttle lock. If the engine doesn't start after 2 or 3 pulls, repeat the entire starting procedure as described for cold starting.

**Do not leave switch (6) in the choke position when hot starting!**

### Stopping the engine

Push the combination switch (6) down to position

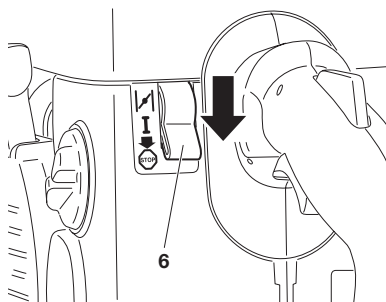

## Adjusting the carburetor



**NOTE:** The grinding parts are equipped with an electronic ignition to limit the speed.

At the factory the idling speed has been set to approx. 2500 rpm, but the running-in process of a new engine may require slight readjustment of the idling speed.

Adjustments to the adjusting screws (L) and (H) may only be made by an authorised MAKITA service centre. Accordingly, the holes for the two screws are sealed shut.

For correct adjustment of the idling speed the following steps must be carried out:

**Start the engine and run it until it is warm** (about 3 - 5 minutes).



Adjust the carburetor with the screwdriver (1, Order No. 944 340 001) included with the Power Cut. It has a lug that helps with adjustment.

### Readjust the idling speed.

If the cut-off disc is still turning when the engine is running, unscrew the adjusting screw of the throttle valve (2) until the cut-off disc is no longer turning. When the engine is left running at idling speed, tighten the screw a little.

**Switch off the engine** 

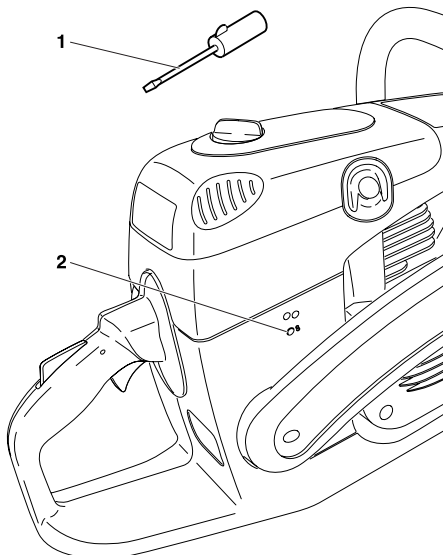

## MAINTENANCE



### CAUTION:

Before doing any work on the Power Cut **turn off the engine**, remove the cutting disc, pull the plug cap off the spark plug and wear protective gloves!

### CAUTION:

Start the Power Cut only after complete assembly and inspection.



## SERVICE

### IMPORTANT:

Because many of the parts and assemblies not mentioned in this Instruction Manual are vital to the safety of the unit, and because all parts are subject to a certain amount of wear and tear, it is important for your own safety that you have the unit checked and maintained regularly by a MAKITA service center.

### IMPORTANT:



If the cutting wheel breaks during cutting, the Power Cut must be repaired by a MAKITA service centre before being used again!

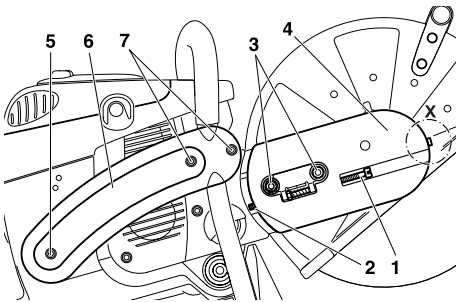

### Changing the V-belt

Loosen nuts (3).

Loosen the tightening screw (1) (counter-clockwise) until the end of the screw (2) is visible in the gap.

Loosen and unscrew the screw (detail X, only for EK8100).

Unscrew the nuts (3) and remove the cover (4).

Remove the screws (5) and (7) and remove the side piece (6).

### NOTE:



Screw (5) is longer than screws (7). Make sure to put them back in the right places during reassembly!

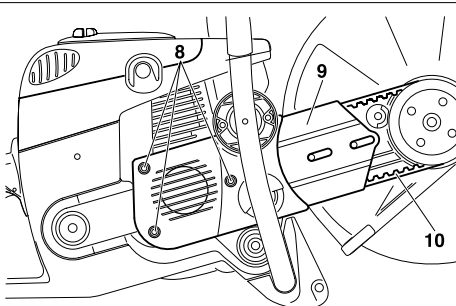

Unscrew the screws (8) and remove the crankcase housing cover (9).

Remove the old belt (10) or belt pieces.

**NOTE:** The illustration shows the V-belt for models EK7300, EK7301.

Clean out the inside of the drive arm with a brush.

Put in a new V-belt.

### NOTE:

Reassemble the crankcase housing cover (9), side piece (6) and cover (4) in the reverse order.

To tighten the V-belt see "Tightening the V-belt / Checking V-belt tension".

### Cleaning the protection hood

Over time, the inside of the protective hood can become caked with material residue (especially from wet cutting), which if allowed to accumulate can hinder the free rotation of the cutting disc. For this reason the hood must be cleaned out from time to time.

Take off the cutting wheel with spring washer and remove the accumulated material from inside the hood with a strip of wood or similar implement.

Clean the shaft and all removed parts.



**NOTE:** To install the cutting wheel see "Mounting the cutting wheel".

### Cleaning / changing the air filter



Turn the cover lock (11) counterclockwise to release it, and carefully remove the filter cover (12).

There is a gasket (15) between the filter cover (12) and the hood (14).

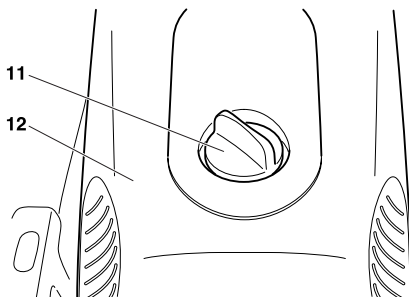

Remove screws (13) and take off the cover (14).  
Clean the gasket (15) with a brush, and check for damage.

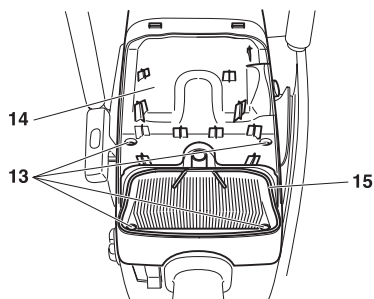

Take the pre-filter (foam, 17) out of the filter cover.  
Pull the air filter insert (paper cartridge, 18) out of the cover.  
Remove the inner filter (16) from the intake opening.

#### Note:

**Do not allow dirt to get into the carburetor!**

Switch the combination switch to "Choke" or cover the carburetor with a clean cloth.

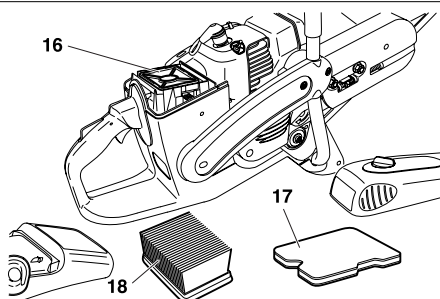

## CAUTION:

Turn off the engine before cleaning the air filter! Never clean out the air filter with compressed air! Do not clean the pre-filter and inner filter with fuel.

The service life of the engine depends on the condition and regular maintenance of the filter elements. Failure to perform maintenance and cleaning at the prescribed intervals will cause increased wear inside the engine!

If the air filter becomes damaged, replace immediately! Pieces of cloth or large dirt particles can destroy the engine! Do not work in dusty conditions when it can be avoided! The fine dust generated when dry-cutting concrete and stone is hazardous to the health of the operator and also shortens the service life of the engine. Whenever possible, wet-cut with water when working in concrete and stone, to bind the dust.

## Pre-filter

If the pre-filter (1, Order No. 395 173 081) is dirty, wash it out in lukewarm water with standard dishwashing liquid.

Rinse out pre-filter thoroughly in running water.

Let the pre-filter **dry thoroughly**.

**NOTE:** The pre-filter must be cleaned daily, or several times daily if working under dusty conditions. If cleaning is not possible on-site, have spare pre-filters on hand. Replace the pre-filter at least every 25 operating hours.

To insert the pre-filter in the filter cover (4), position it so it fits the space in the cover and then press it in (5). The pre-filter must fit completely and cover all parts of the filter space, without leaving any spaces unfiltered.

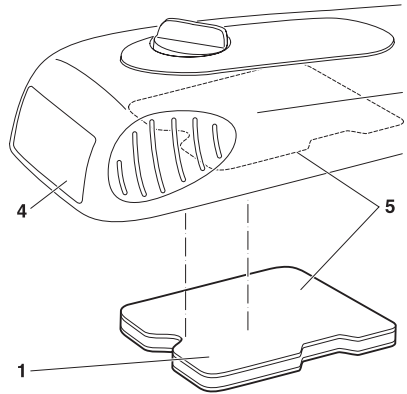

## Inner filters

Wash out the dirty inner filter (3, Order No. 395 173 020) in lukewarm soapy water with regular dishwashing liquid.

Let the inner filter **dry thoroughly**.

## Air filter insert

The air filter insert (2, Order No. 395 173 011) filters the intake air through a very fine paper filter lamella system. For the reason the cartridge **must never be washed**. Clean the air filter insert once a week.

To clean the air filter insert, spread it out slightly and carefully tap it against a clean surface.

Replace the air filter insert every 100 operating hours. Replace it immediately if there is a drop in power, drop in speed, or smoke in the exhaust.

Before installing the filter system, check the intake opening to make sure no dirt particles have fallen in. If they have, remove them.

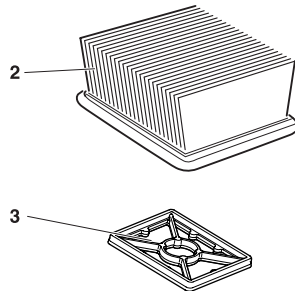

## Replacing the spark plug



### CAUTION:

Do not touch the spark plug or plug cap if the engine is running (high voltage).

Switch off the engine before starting any maintenance work.

A hot engine can cause burns. Wear protective gloves!

The spark plug (Order No. 965 603 021) must be replaced in case of damage to the insulator, electrode erosion (burn) or if the electrodes are very dirty or oily.

Remove the filter cover and hood. See **Cleaning / changing the air filter**.

Pull the plug cap (7) off the spark plug. Use only the combination wrench supplied with the saw to remove the spark plug.

**CAUTION: To prevent damage to the decompression valve (8), when unscrewing the spark plug position the combination tool in such a way that it does not impact the valve.**

### Electrode gap

The electrode gap must be 0.5 mm.

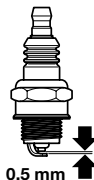
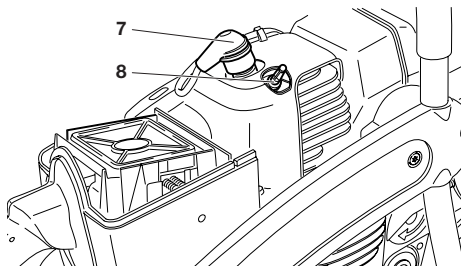

**CAUTION:** Use only BOSCH WSR 6F spark plug, CHAMPION RCJ-6Y or NGK BPMR 7A.

## Checking the ignition spark

Insert the combination tool (9) between the ventilation hood and cylinder only as shown in the illustration.

### CAUTION!

Do **not** insert the combination tool into the spark plug hole, but make contact **only** with the cylinder (otherwise you may damage the engine).

Using insulated pliers, hold the spark plug (10) (unscrewed but with the plug cap on) against the combination tool (away from the spark plug hole!).

Switch the combination switch (11) to "I".

Pull the starter cable hard.

If the function is correct, an ignition spark must be visible near the electrodes.

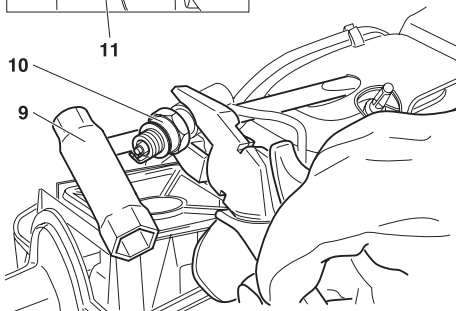
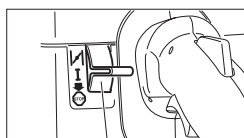

## Replacing the suction head

The felt filter (13) of the suction head can become clogged. It is recommended to replace the suction head once every three months in order to ensure unimpeded fuel flow to the carburetor.

Unscrew the tank cap (12), pull the retainer out of the opening.

Empty fuel tank.

Use a wire hook to pull the suction out of the tank opening for replacement.

**Caution:** Do not allow fuel to come into contact with skin!

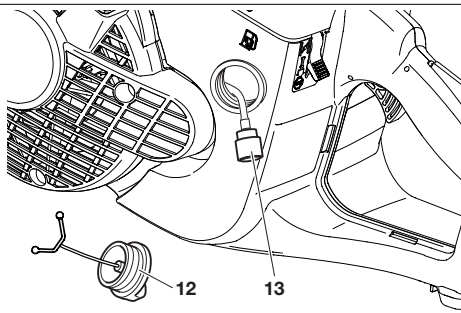

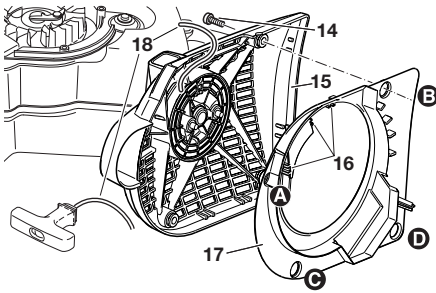

## Replacing the starter cable



Remove four screws (14). Remove starter housing (15).

Insert a small screwdriver through the cooling slits on the back of the starter housing. Push aside the tabs (16) slightly and carefully remove the air guide (17) from the starter housing (15). Proceed in the order (A - B - C - D).

**If replacing a starter cable that has not come apart, it will first be necessary to de-tension the return spring on the cable drum.**

To do this, pull the starter grip all the way out of the starter housing.

Hold the cable drum firmly with one hand, and with the other guide the starter cable into the recess (24) and hold it.

Now carefully let the cable drum turn counter-clockwise until the return spring is completely de-tensioned.

Remove all pieces of cable (18).

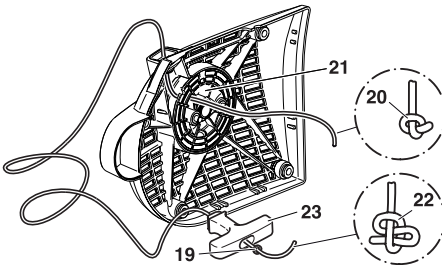

Thread in a new starter cable (dia 4.0 mm, length 1000 mm) as shown (don't forget the disc (19)) and knot both ends.

Pull knot (20) into the cable pulley (21).

**CAUTION:** Do not let the knots or the cable ends protrude from the outside of the cable pulley.

Pull knot (22) into the cable grip (23).

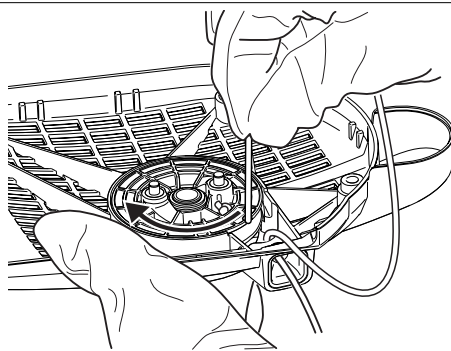

Guide the cable into the recess (24) on the cable drum and use the cable to turn the drum two turns in the direction shown by the arrow.

Holding the cable drum in your left hand, straighten out the twist in the cable with your right hand, pull the cable tight, and hold.

Release the cable drum. The drum's spring force will now wind the cable around the drum.

**Repeat three times.** The starter grip must be upright on the starter housing.

**NOTE:** With the cable pulled all the way out, it must still be possible to turn the pulley another 1/4 turn against the return spring.

### CAUTION!

**Injury hazard! When you pull out the starter cable hold the starter handle firmly. It will whip back if the cable pulley is released by accident.**

Install the air guide (17) in reverse order. Make sure that the tabs (16) click back into the starter housing.

When putting the starter housing back on, it may be necessary to pull the starter handle slightly until the starting mechanism engages.

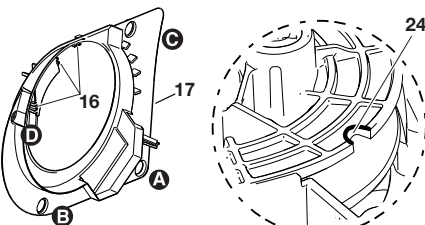

## Replacing the return spring



Remove the starter housing (see "Replacing the starter cable").

Take the air guide off the starter housing (see "Replacing the starter cable").

De-tension the return spring on the cable drum (see "Replacing the starter cable").

Take off circlip (1) (circlip pliers, see "Accessories").

Remove the cable pulley (2).

Evenly lever the return spring (4) out of the catch using a screwdriver or similar tool. **Be extremely careful - the return spring is under tension and can pop out of its housing!**

**CAUTION! Injury hazard! Wear eye protection and work gloves when performing this work!**

Replacement return springs are delivered already tensioned in the housing. **CAREFUL - the spring can pop out.** If it does, it can be put back in as shown in the diagram (**observe the direction of rotation**).

Before installing the new return spring (4) in the starter housing, grease it lightly with multipurpose grease, Order No. 944 360 000. Then position it and press it until the tabs (5) engage in the slots.

Do not grease the cable drum (2) or bearing journal!

Turn the cable pulley slightly when putting it back on, until you hear it catch. Put the circlip back on.

Wind on the starter cable (see above under "Replacing the starter cable").

Reinstall the air guide (see above under "Replacing the starter cable").

When putting the starter housing back on, it may be necessary to pull the starter handle slightly until the starting mechanism engages.

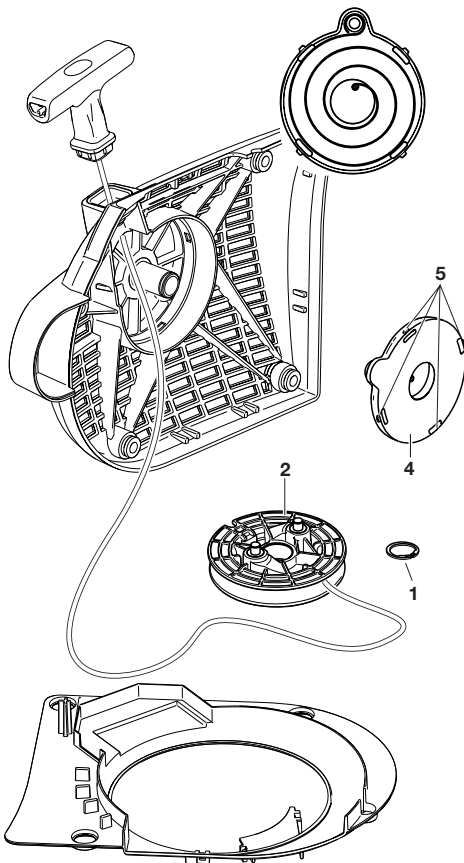



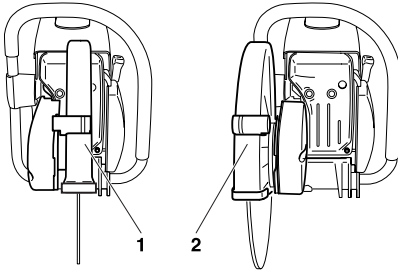

### Cutting attachment in central / side position

**NOTE:** The Power Cut is delivered with the cutting attachment mounted in the middle position (1). For cutting up against obstacles, such as curbs or walls, the cutting attachment can be mounted to one side (2). Use this position only when actually necessary, and afterwards return the cutting attachment to the middle position

In this position the Power Cut has better balance, is easier to guide, and is not as fatiguing for the operator.

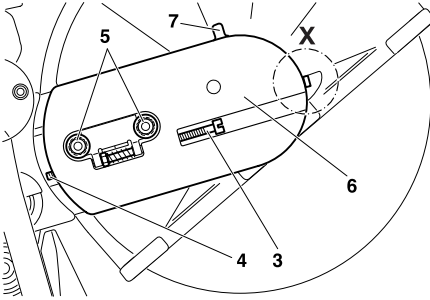

### Repositioning the cutting attachment



Loosen nuts (5).

Loosen the tightening screw (3) (counter-clockwise) until the end of the screw (4) is visible in the gap.

Loosen and unscrew the screw (detail X, only for EK8100).

Unscrew the nuts (5) and remove the cover (6).

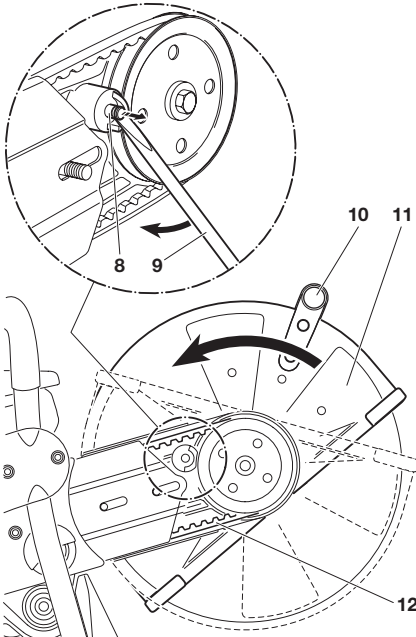

Use the combination tool (8) to lever out the stop pin (9) as shown in the illustration, until the protective hood (11) can be turned.

**NOTE:** The turn stop (7) is deactivated when the stop pin (8) is removed. This permits the hood (11) to be turned farther than the turn stop (7).

Unscrew the grip (10) and turn the protective hood (11) as shown in the illustration.

Disengage the V-belt (12) and remove the cutting attachment.

**NOTE:** The illustration shows the V-belt for models EK7300, EK7301.

Press the cutting attachment (13) onto the drive arm in the side position.

Guide the V-belt (14) over the V-belt pulley (15).

**NOTE:** The illustration shows the V-belt for models EK7300, EK7301.

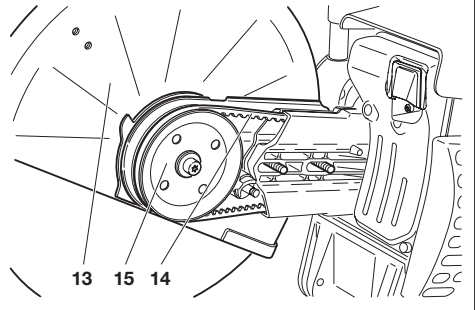

Put the guard plate (16) on.

Screw on nuts (17) and tighten by hand.

To tighten the V-belt see "Tightening the V-belt / Checking V-belt tension".

Screw in and tighten the screw (detail X, only for EK8100).

Tighten the nuts (17) firmly with the combination wrench.

Replace the grip (18) as shown.

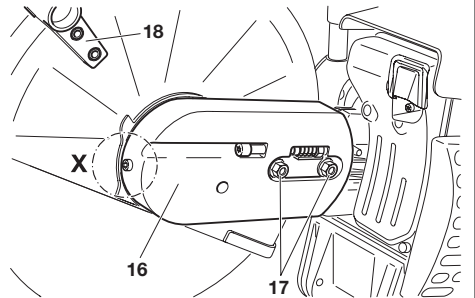

### **IMPORTANT:**

**When you reposition the cutting attachment, the direction of rotation of the cutting wheel changes.**



**If a rotation direction is marked on the cutting disc, make sure the disc turns in the right direction.**

### **Replacing/cleaning the spark arrester screen**



**Caution:** Do not use sharp or pointed objects for screen cleaning. Damaged or misformed screen wires may result.

**Let cool the engine down for sure!**

The spark arrester screen should be checked and cleaned regularly. Replace spark arrester screen when needed.

Loosen the screw (25) and remove the spark arrester screen (26).

Reassembly the spark arrester screen and tighten the screw.

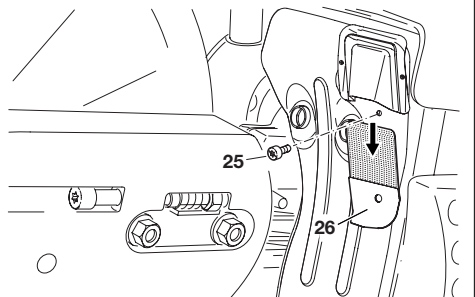

## SPECIAL ACCESSORIES

### Diamond cutting discs (1)

MAKITA diamond cutting discs meet the highest demands in working safety, ease of operation, and economical cutting performance. They can be used for cutting all materials **except metal**.

The high durability of the diamond grains ensures low wear and thereby a very long service life with almost no change in disc diameter over the lifetime of the disc. This gives consistent cutting performance and thus high economy. The outstanding cutting qualities of the discs make cutting easier.

The metal disc plates give highly concentric running for minimal vibration during use.

The use of diamond cutting discs reduces cutting time significantly. This in turn leads to lower operating costs (fuel consumption, wear on parts, repairs, and last but not least environmental damage).

### Guide trolley (2)

The MAKITA guide trolley makes it much easier to do straight cuts, while simultaneously enabling almost untiring working. It can be adjusted for the operator's height, and can be operated with the cutting attachment mounted in the middle or on the side.

NOTE: Before mounting the Power Cut on the guide trolley, it will be necessary to remove the stand (see illustration (\*) in the chapter "Extract from the spare parts list").

For easier refuelling when using the trolley, we recommend adding an angled tank filler neck (3).

A depth limiter can be added for still easier and more accurate cutting. It makes it possible to maintain a precise predetermined cut depth (4).

To keep down dust and for better cutting-disc cooling, MAKITA offers several options for wetting the disc during operation.

### Water tank (5)

The water tank is designed to be mounted on the guide trolley. Its high capacity makes it especially suitable for situations involving frequent site changes. For filling or for fast changing to reserve tanks, the tank can be simply lifted off the trolley.

The water tank comes with all necessary connections and hoses. Mounting to the trolley and Power Cut are very fast and simple.

### Mains/pressure water system (6)

The mains/pressure water system is designed to be mounted on the Power Cut. It can be used with or without the trolley, but is especially suitable for applications involving hand-held, stationary cutting. The water line has a fast-release connection, and can be fed either from a mains supply or from a pressure tank (7).

The water system comes with all necessary connections and lines. It can be quickly and easily mounted on the Power Cut.

See "Accessories" for order number.

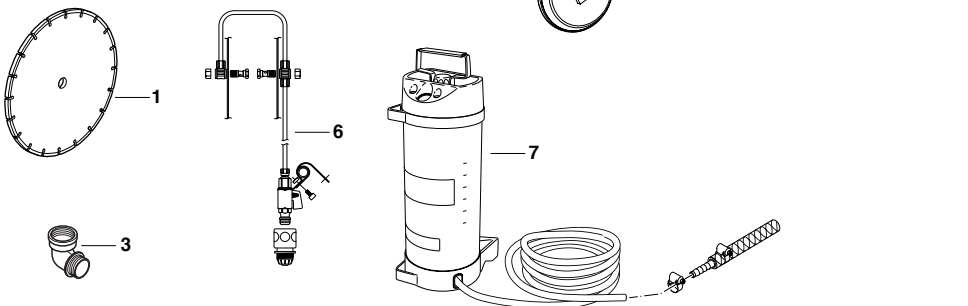

## Instructions for periodic maintenance

To ensure long life, prevent damage and ensure the full functioning of the safety features the following maintenance must be performed regularly. Guarantee claims can be recognized only if this work is performed regularly and properly. Failure to perform the prescribed maintenance work can lead to accidents!

Users of the Power Cut must not perform any maintenance work not described in this Instruction Manual. All such work must be carried out by a MAKITA service centre.

			Page
<b>General</b>	Entire Power Cut	Clean exterior, check for damage. In case of damage, have repaired by a qualified service centre immediately	6
	Cutting disc	Inspect regularly for damage and wear.	
	Clutch	Have inspected at a service center.	16
	Protection hood	Clean, Check position (impact plate)	
<b>Before each start</b>	Cutting disc	Inspect for damage and make sure the cutting wheel is right for the job	6
	V-belt	Check V-belt tension	14
	Protective hood	Adjust position	17
	Combination switch,	Functional check	
	Safety locking button,	Functional check	
	Throttle lever	Functional check	
Tank cap	Check for tightness		
<b>Every day</b>	Air filter	Clean (if necessary more frequently); pre-filter (foam) maintenance as described above under <b>Cleaning / changing the air filter</b>	20-21
	Idle speed	Check (cutting disc must not turn on idle)	18
<b>Every week</b>	Starter housing	Clean to ensure proper air cooling	12
	Starter cable	Check for damage	23
	V-belt	Check V-belt tension, inspect for damage and wear	14, 19
	Air filter insert	Clean, replace after 100 operating hours	21
	Spark plug	Check and replace if necessary	22
	Muffler	Check tightness of mounting	12
	Spark arrester screen	Clen and replace if necessary	26
	Screws and nuts	Check their condition and that they are firmly secured.	
<b>Every 3 months</b>	Suction head	Replace	22
	Fuel tank	Clean	
<b>Annually</b>	Entire Power Cut	Check at an authorized service centre	
<b>Storage</b>	Entire Power Cut	Clean exterior, check for damage. In case of damage, have repaired by a qualified service centre immediately	13
	Cutting disc	Remove and clean	
	Fuel tank	Empty and clean	
	Carburetor	Run empty	

## Service, spare parts and guarantee

### Maintenance and repair

The maintenance and repair of modern cutoff saws and their safety-related components requires qualified technical training and a workshop equipped with special tools and testing devices.

We therefore recommend that you consult a MAKITA service centre for all work not described in this instruction manual.

The MAKITA service centres have all the necessary equipment and skilled and experienced personnel, who can work out cost-effective solutions and advise you in all matters.

To find your local distributor, please visit [www.makita-outdoor.com](http://www.makita-outdoor.com)

### Spare parts

Reliable long-term operation, as well as the safety of your Power Cut, depend among other things on the quality of the spare parts used. Use only original MAKITA parts, marked 

Only original parts are from the same production line as the original unit and therefore ensure the highest possible quality of materials, dimensions, functioning and safety.

Only original spare parts and accessories guarantee the highest quality in material, dimensions and function.

Original spare parts and accessories can be obtained from your local dealer. He will also have the spare part lists to determine the required spare part numbers, and will be constantly informed about the latest improvements and spare part innovations.

Please bear in mind that if parts other than original MAKITA spare parts are used, this will automatically invalidate the MAKITA product guarantee.

We will furthermore not accept any liability damages arising from the use of non-MAKITA spare parts.

## Guarantee

MAKITA guarantees the highest quality and will therefore reimburse all costs for repair by replacement of damaged parts resulting from material or production faults occurring within the guarantee period after purchase. Please note that in some countries particular guarantee conditions may exist. If you have any questions, please contact your salesman, who is responsible for the guarantee of the product.

Please note that we cannot accept any responsibility for damage caused by:

- Disregard of the instruction manual.
- Non-performance of the required maintenance and cleaning.
- Incorrect carburetor adjustment.
- Normal wear and tear.
- Obvious overloading due to permanent exceeding of the upper performance limits.
- The use of other than original MAKITA cutting discs.
- Use of force, improper use, misuse or accidents.
- Damage from overheating due to dirt on the fan housing.
- Work on the Power Cut by unskilled persons or inappropriate repairs.
- Use of unsuitable spare parts or parts which are not original MAKITA parts, insofar as they have caused the damage.
- Use of unsuitable or old oil.
- Damage related to conditions arising from lease or rent contracts.
- Damages caused by disregarding loose outer bolted connections.

Cleaning, servicing and adjustment work is not covered by the guarantee. All repairs covered by the guarantee must be performed by a MAKITA service centre.

## Troubleshooting

Malfunction	System	Observation	Cause
Cutting disc does not start turning	Clutch	Engine runs	Damage to clutch
Cutting disc runs in idle	Carburetor, clutch V-belt	Cutting disc runs	Incorrect idle speed, blocked clutch Belt has insufficient tension, V-belt is worn
Engine does not start or only with difficulty	Ignition system  Fuel supply  Compression system  Mechanical malfunction	Ignition spark  No ignition spark  Fuel tank is filled  Inside  Outside Starter does not engage	Malfuction in fuel supply system, compression system, mechanical malfunction. Switch on STOP, fault or short-circuit in the wiring, plug cap or spark plug defective. Choke in wrong position, carburetor defective, suction head dirty, fuel line bent or interrupted. Cylinder base packing ring defective, radial shaft packings defective, cylinder or piston rings defective Spark plug does not seal. Spring in starter broken, broken parts inside the engine.
Warm start difficulties	Carburetor	Fuel tank is filled	Wrong carburetor adjustment. Ignition spark
Engine starts, but dies immediately	Fuel supply	Fuel tank is filled	Wrong idling adjustment, suction head or carburetor dirty. Tank venting defective, fuel line interrupted, cable defective, STOP switch defective. Decompression valve dirty
Insufficient power	Several systems may be involved simultaneously	Engine is idling	Air filter dirty, wrong carburetor adjustment, muffler clogged, exhaust channel in cylinder clogged, spark arrester screen clogged

### Extract from the spare parts list

Use only original MAKITA parts. For repairs and replacement of other parts, see your MAKITA service centre.

EK7300

EK7301

EK8100

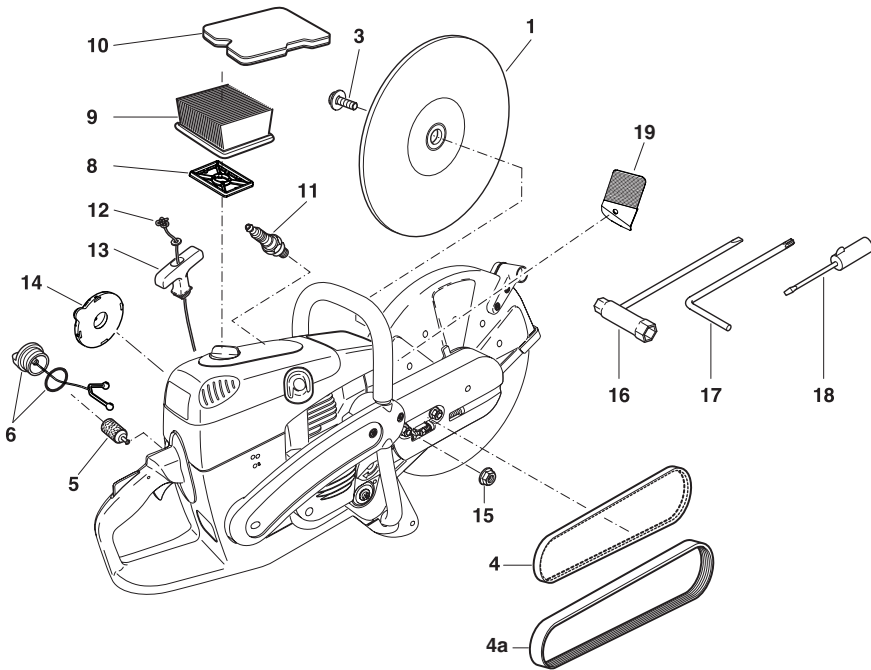

25

26

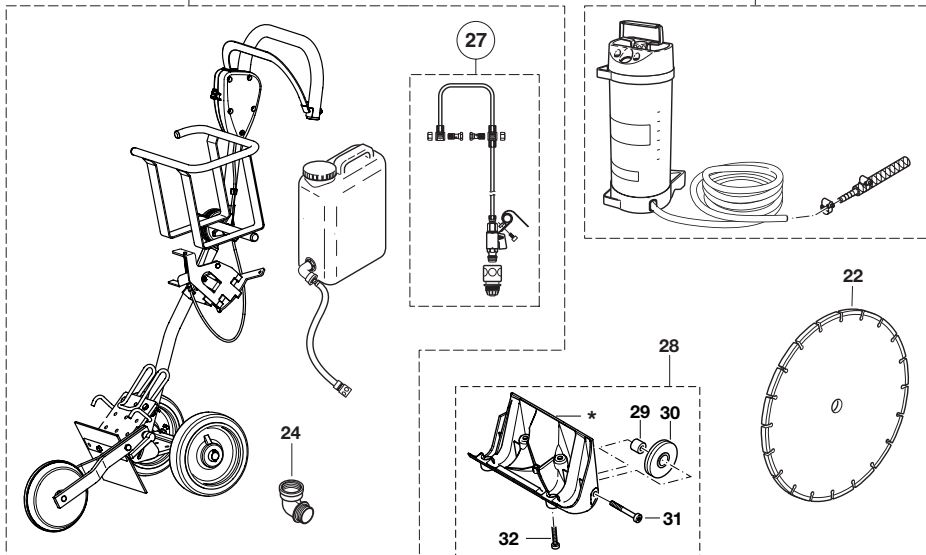

## Extract from the spare parts list

Use only original MAKITA parts. For repairs and replacement of other parts, see your MAKITA service centre.

**EK7300**  
**EK7301**  
**EK8100**



Pos.	MAKITA-No.	Qty.	Denomination
<b>Synthetic resin cutting disc</b>			
1	966 121 150	1	Cutting disc for steel, dia. 300/20 mm
	966 141 150	1	Cutting disc for steel, dia. 350/20 mm
	966 144 150	1	Cutting disc for steel, dia. 350/25,4 mm
	966 161 050	1	Cutting disc for steel, dia. 400/20 mm
1	966 121 120	1	Cutting disc for masonry, dia. 300/20 mm
	966 141 120	1	Cutting disc for masonry, dia. 350/20 mm
	966 144 120	1	Cutting disc for masonry, dia. 350/25,4 mm
	966 161 120	1	Cutting disc for masonry, dia. 400/20 mm
3	994 280 250	1	Hex screw M8x25
4	965 300 470	1	V-belt (for EK7300, EK7301)
4a	965 300 481	1	V-belt (for EK8100)
5	963 601 122	1	Suction head
6	181 114 202	1	Tank cap, compl. (fuel)
8	395 173 020	1	Inner filter
9	395 173 011	1	Air filter insert (paper cartridge)
10	395 173 081	1	Pre-filter (foam)
11	965 603 021	1	Spark plug
12	122 164 010	1	Starter cable $\varnothing$ 4,0x1000 mm
13	001 161 020	1	Starter grip
14	181 163 050	1	Return spring in housing
15	923 208 004	2	Hexagonal nut M8
16	941 719 140	1	Universal wrench SW 13/19
17	940 827 000	1	Offset screwdriver T27
18	944 340 001	1	Screwdriver (carburetor)
19	395 174 140	1	Spark arrester screen

### Accessories (not delivered with the Power Cut)

<b>Diamond cutting disc</b>			
22	966 . . . . .	1	Please consult your MAKITA dealer!
-	394 228 121	1	Adapter ring, dia. 20/25,4 mm
24	957 114 200	1	Angle fuel-tank filler neck, cpl.
25	394 369 600	1	Guide trolley DT2010 cpl.
26	957 802 600	1	Pressure water tank, cpl.
27	394 365 102	1	Mains water connection, cpl.
28	394 114 271	1	Stand with rollers, complete (included only with EK8100, but without items 29, 30, 31)
29	394 114 240	2	Bushing
30	394 114 230	2	Roller
31	908 006 355	2	Star-head screw
32	908 905 165	4	Star-head screw
-	949 000 035	1	Combined can (for 5l fuel, 2.5l oil)

## EU Conformity Declaration

The undersigned, Tomoyasu Kato, as authorized by MAKITA Corporation, declare that the MAKITA machines,

**Type:** 395, 328

**Power Cut EK7300, EK7301 (395), EK8100 (328)**

manufactured by MAKITA Corporation, 3-11-8 Sumiyoshi-Cho, Anjo, Aichi, 446-8502 Japan, conforms to the basic safety and health requirements of the applicable EU Directives:

EU Machinery Directive 2006/42/EG, EU EMC Directive 2004/108/EG, Outdoor Noise Directive 2000/14/EG.

The most important standards applied to properly meet the requirements of the above EU Directive were: EN 19432, CISPR 12, EN ISO 14982, DIN EN 61000-4. The conformity assessment procedure 2000/14/EG was performed per Annex V. The measured noise level ( $L_{wa}$ ) is 114 dB(A). The guaranteed noise level ( $L_n$ ) is 115 dB(A).

The technical documentation is on file at MAKITA International Europe Ltd., Michigan Drive, Tongwell, Milton Keynes, Bucks, MK15 8JD, England.

Anjo, 1.10.2012 for MAKITA Corporation

Tomoyasu Kato  
Managing Director



This print product has been awarded the "Blue Angel".

To find your local distributor, please visit  
[www.makita-outdoor.com](http://www.makita-outdoor.com)



MAKITA Corporation  
3-11-8 Sumiyoshi-Cho  
Anjo, Aichi  
446-8502 Japan

Specifications subject to change without notice

Form: 995 704 566 (2013-10 GB)