

TECHNICAL INFORMATION

Models No. ▶ UB120D / UB140D

Description ▶ Cordless blower

CONCEPTION AND MAIN APPLICATIONS

This model is our first 12V / 14.4V cordless blower for blow and suction being equipped with variable speed control switch and dial lock button for controlling air volume in 3 stage.

The variations of this mode are as follows.

Model No.	Battery	Charger	Dust bag
UB120DWA	1222 (Ni-Cd)	DC1411	without
UB120DWB	1223 (Ni-MH)	DC1411	without
UB140DWA	1422 (Ni-Cd)	DC1411	without
UB140DWB	1433 (Ni-MH)	DC1411	without

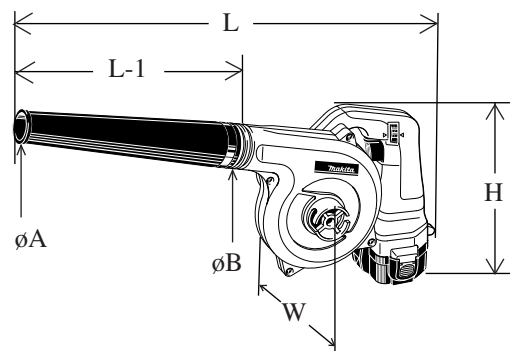

Dimensions : mm (")		
Model No.	UB120D	UB140D
Width (W)	155 (6-1/8)	155 (6-1/8)
Height (H)	203 (8)	208 (3-3/16)
Length (L)	516 (20-5/16)	516 (20-5/16)
Nozzle (L-1)	220 (8-5/8)	220 (8-5/8)
Diameter (A)	33 (1-5/16)	50 (2)
Diameter (B)	33 (1-5/16)	50 (2)

► Specification

Motor	DC magnet motor RS775VH	
Battery	UB120D	Ni-Cd 12V 2.0Ah Ni-MH 12V 2.2Ah
	UB140D	Ni-Cd 14.4V 2.0Ah Ni-MH 14.4V 2.2Ah
No load speed : min-rpm.	0 - 18,000	
Air volume (m³/s)	0.37 (2.2 m ³ /min.)	
Air pressure (kPa)	6.0 (610mmH ₂ O Water. column mm)	
Net weight including battery : Kg (lbs)	UB120D	1.8 (4.0)
	UB140D	1.9 (4.2)

► Standard equipment

- * Nozzle 1 pc.
- * Set plate 1 pc. (only for UB120D)
- * Battery cover 1 pc.

< Note > The standard equipment for the tool shown may differ from country to country.

► Optional accessories

- * Long nozzle
- * Dust bag
- * Flexible hose set
- * Anchor nozzle
- * Fast charger DC1409
- * Fast charger DC1809
- * Charger DC1411
- * Charger DC1411
- * Charger DC1801
- * Ni-Cd.battery 1222 for UB120D
- * Ni-Cd.battery 1200 for UB120D
- * Ni-Cd.battery 1202 for UB120D
- * Ni-Cd.battery 1202A for UB120D
- * Ni-Cd.battery 1220 for UB120D
- * Ni-MH.battery 1233 for UB120D
- * Ni-Cd.battery 1422 for UB140D
- * Ni-MH.battery 1433 for UB140D

(1) Change of fan

Hold fan 86 with your hand after removing fan housing. And then take off pan head screw M5x8 from fan 86.

(2) Changing and assembling DC motor

DC motor can be removed after dismantling fan housing complete, fan 86 and another fan housing complete.

When mounting DC motor, pay attention to the following points.

- * The convexes of motor rubber ring A have to be fitted on the ribs of motor housing. (see Fig.1)
- * Motor rubber ring A has to be inserted protruding on the motor housing as per Fig.2.

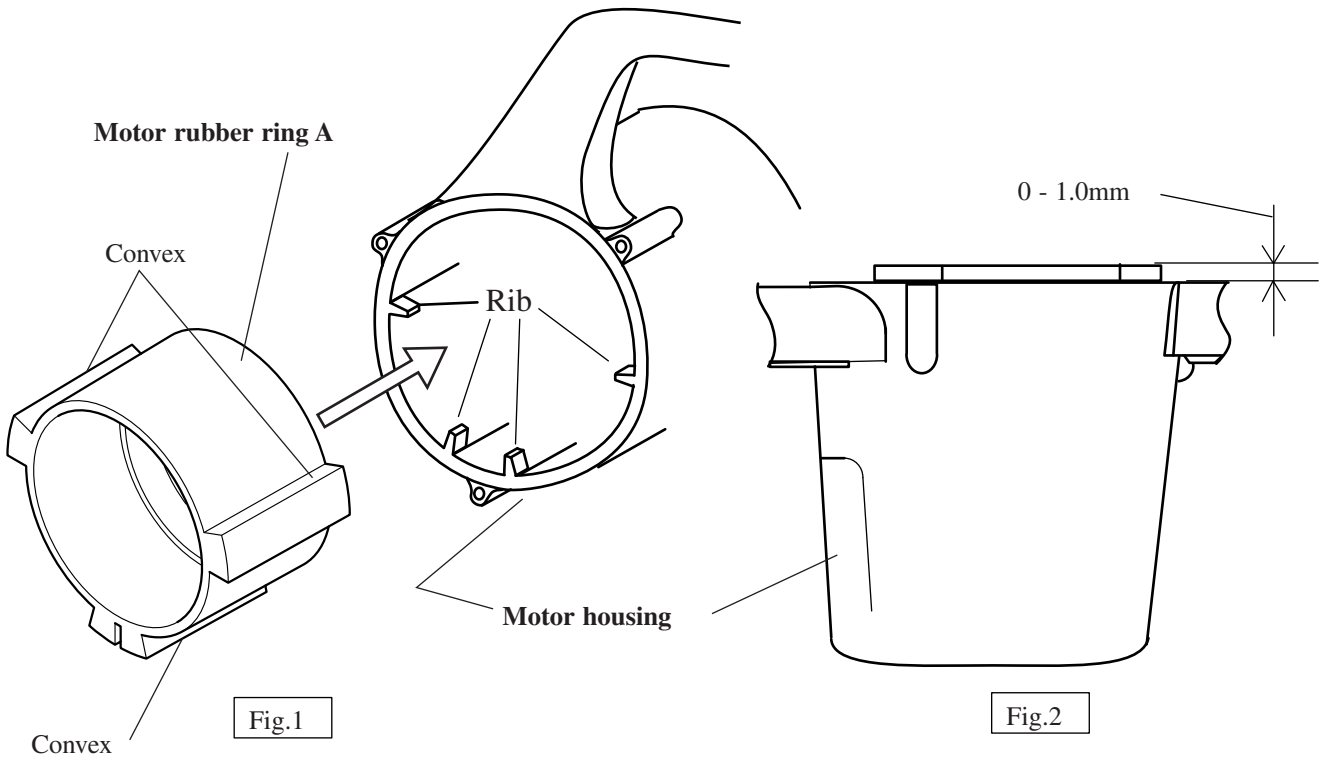

(3) Assembling leaf spring at the back of dial 32

Assemble leaf spring into motor housing as per the Fig.3.

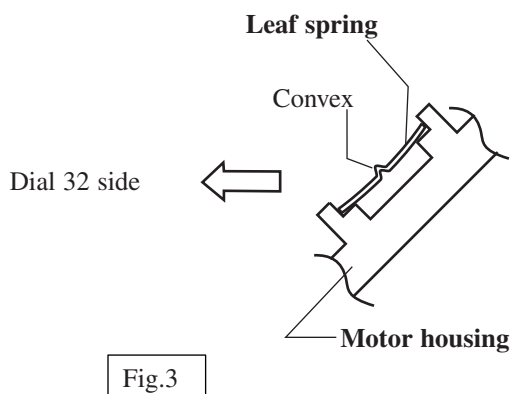

After assembling dial 32 and handle cover, check whether the dial 32 clicks at every position of 1, 2 and 3.

(4) Position of reversible lever

The switches for these models are equipped with reversible lever. Make sure, the reversible lever is directed to left side as per the Fig.4.

If the position of reversible lever is another than Fig.4, handle cover can not be assembled on motor housing.

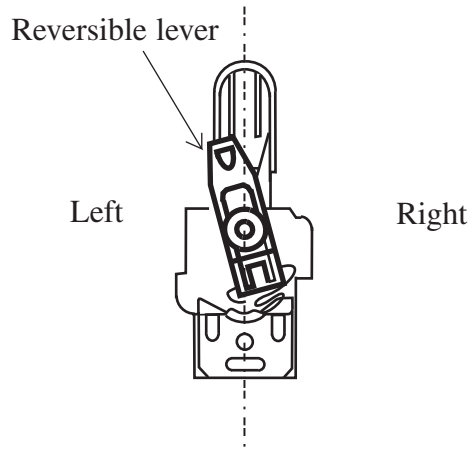

Fig.4

(5) Rotating direction of fan 86

Switch on and make sure, fan 86 rotates anti-clockwise. The rotating direction can be checked through the air intake. See Fig5.

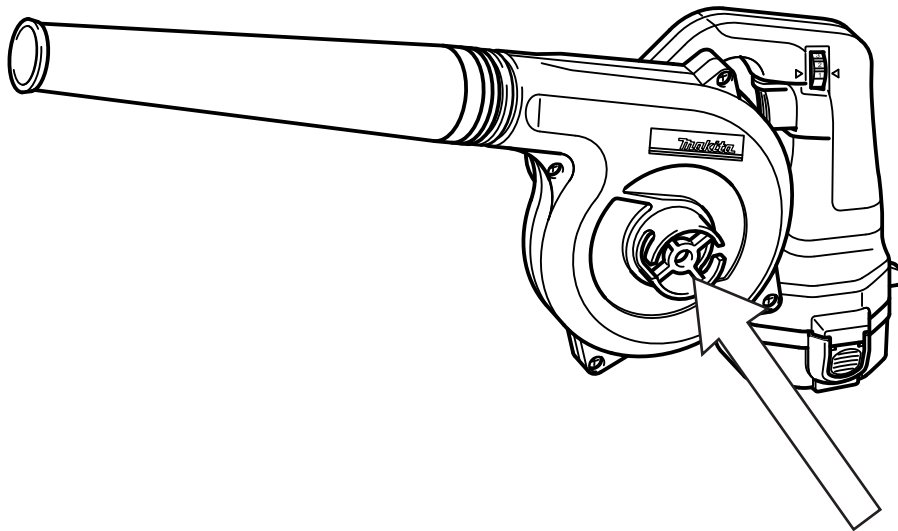
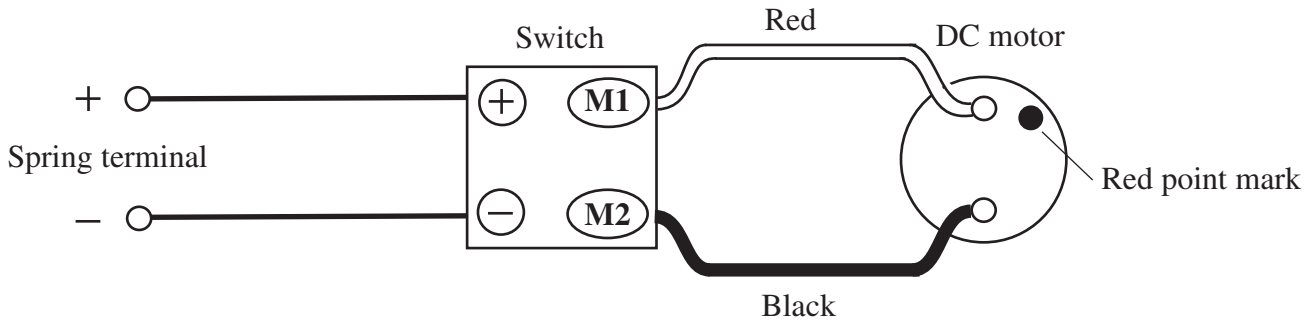

Fig.5

Air intake



1. Connection of lead wire to DC motor

* Adjust the hole of motor rubber ring B to the red point mark of DC motor so that the red point mark can be recognized through the hole of motor rubber ring B.

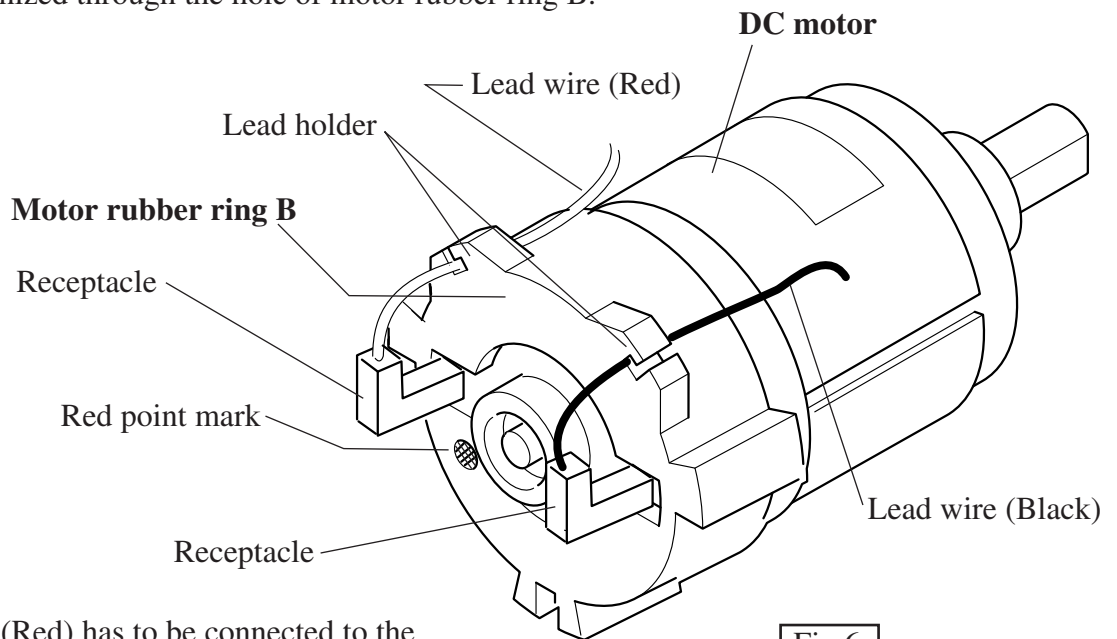

Fig.6

* Lead wire (Red) has to be connected to the terminal of red point mark side.(see Fig.6)

* Receptacles have to be assembled so that the lead wires can be guided through the lead holders smoothly. (see Fig.6)

2. Setting lead wires at the opening of motor housing

Lead wires (Red and Black) have to be set in the lead holder without slack.

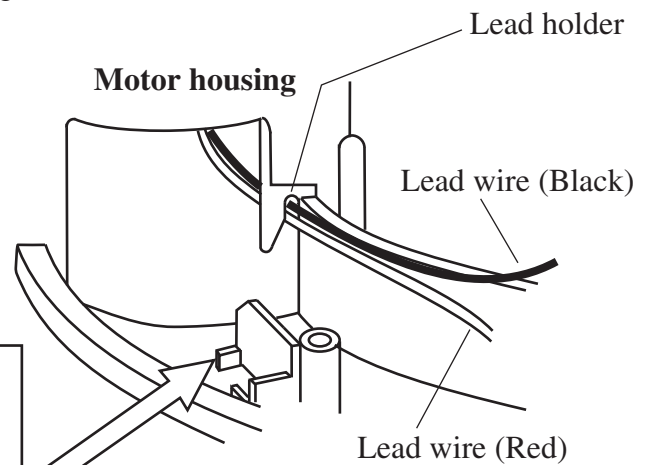
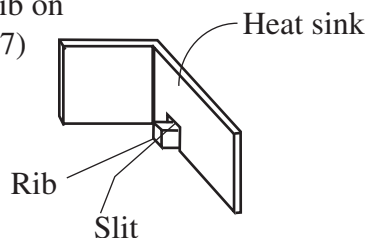
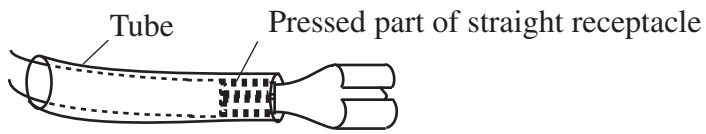

Fig.7

When setting heat sink, assemble it adjusting the slit to the rib on motor housing. (see Fig.7)





Straight receptacle has to be covered to the pressed part with tube.

