

TECHNICAL INFORMATION



PRODUCT

P 1 / 27

Model No. ▶ RP2300FC, RP2301FC

Description ▶ Router

CONCEPT AND MAIN APPLICATIONS

Models RP2300FC and RP2301FC are upgraded sister tools of our current plunge-type electronic router Model 3612C. Their main benefits are:

- Linear ball bearing for super-smooth plunge action
 - Ergonomically contoured knob style handles
- Powerful cutting with the continuous rating input higher than Model 3612C;
 RP2300FC: 2,300W, RP2301FC: 2,100W

RP2301FC additionally feature electric brake.

These products are available in the following variations.

Model No.	Electric brake	Twin LED job lights	Straight guide
RP2300FC	No	Yes	Standard type (Straight guide + Guide holder assembly)
RP2301FC	Yes		High-precision type with fine adjustment function (Fine adjusting straight guide)
RP2300FCX	No		
RP2301FCX	Yes		

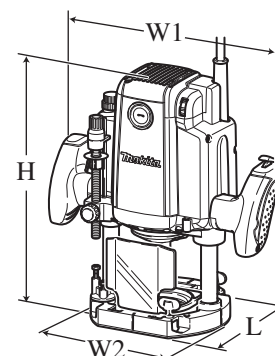

Dimensions: mm (")	
Length (L)	155 (6-1/8)
Width (W1)	294 (11-5/8)
Height (H)	312 (12-1/4)
Width of base (W2)	170 (6-11/16)

► Specification

RP2300FC

Voltage (V)	Current (A)	Cycle (Hz)	Continuous Rating (W)		Max. Output (W)
			Input	Output	
110	15	50/60	1,650	650	2,600
120	15	50/60	---	650	2,600
220	11	50/60	2,300	1,200	3,400
230	11	50/60	2,300	1,200	3,400
240	11	50/60	2,300	1,200	3,400

RP2301FC

Voltage (V)	Current (A)	Cycle (Hz)	Continuous Rating (W)		Max. Output (W)
			Input	Output	
110	15	50/60	1,650	650	2,600
120	15	50/60	---	650	2,600
220	10	50/60	2,100	1,000	3,400
230	10	50/60	2,100	1,000	3,400
240	10	50/60	2,100	1,000	3,400

Model No.	RP2300FC	RP2301FC
No load speed: min-1=rpm	9,000 - 22,000	
Collet capacity: mm (")	12.0 or 12.7 (1/2)	
Plunge capacity: mm (")	0 - 70 (0 - 2-3/4)	
Electronic control	Constant speed control	Yes
	Soft start	Yes
	Variable speed control by dial	Yes
Electric brake	No	Yes
LED job light	Yes*1	
Double insulation	Yes	
Power supply cord: m (ft)	Europe: 4.0 (13.1), Brazil: 2.0 (6.6), Other countries: 2.5 (8.2)	
Net weight*2: kg (lbs)	6.1 (13.4)	

*1: Twin LED job lights with afterglow function

*2 Weight according to EPTA-Procedure 01/2003, including Dust nozzle

(See next page for Standard equipment and Optional accessories.)

► Standard equipment

For all countries:

Straight guide (Standard type or High-precision type)	1 pc	Collet cone 12mm or 1/2"	1 pc
+ Pan head screw M6x135 (for adjusting cutting depth)	1 pc	Wrench 24	1 pc

The standard equipment for the tool shown below may vary by country:

Dust nozzle assembly	1 pc	Collet sleeve 6mm	1 pc	Collet sleeve (for inch chuck) 10mm	1 pc
Knob 55 complete	1 pc	Collet sleeve 8mm	1 pc		
Trimmer guide assembly	1 pc	Collet sleeve 1/4"	1 pc		
Templet guide 16	1 pc	Collet sleeve 3/8"	1 pc		

► Optional accessories

Fine adjusting straight guide	Templet guide 25	Collet sleeves
Guide rail adapter set	Templet guide adapter 30	Router bits
Trimmer guide assembly	Nut M30	
Templet guides	Dust nozzle assembly	

► Repair

CAUTION: Remove the bit from the machine for safety before repair/ maintenance in accordance with the instruction manual!

[1] NECESSARY REPAIRING TOOLS

Code No.	Description	Use for
1R030	Bearing setting pipe 25-17.2	Supporting Pin 6 when assembling shaft lock mechanism
1R041	Vise plate	Protecting Armature when holding in vise
1R268	Spring pin extractor 3	Removing Pin 6 of shaft lock mechanism
1R269	Bearing extractor	Removing Ball bearing 629DDW

[2] LUBRICATIONS

Apply lubricant “VG100” to the following portions designated with the gray triangle to protect parts and product from unusual abrasion.

Item No.	Description	Portion to lubricate
②4	Armature	Threaded portion for removing Collet nut smoothly
⑧5	Base complete	Pipe 20 for making plunging action smooth

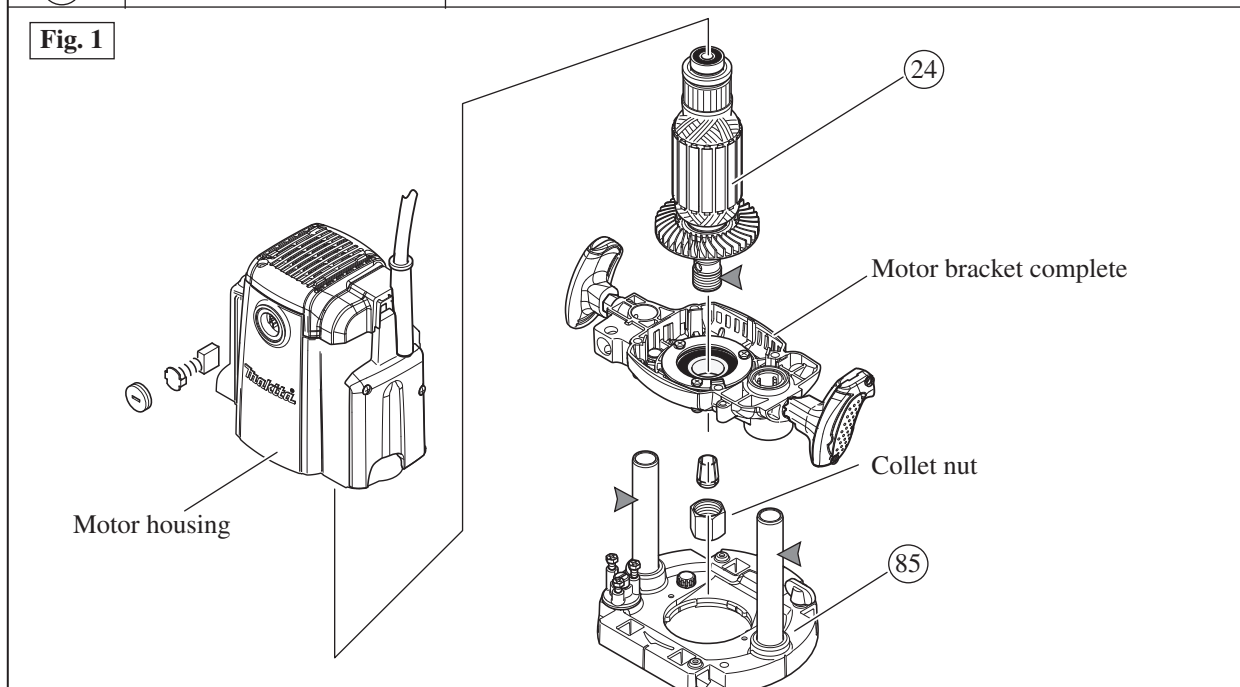

[3] DISASSEMBLY/ASSEMBLY

[3]-1. Base complete

DISASSEMBLING

(1) Separate Base section from Motor section as illustrated in **Figs. 2 and 3**.

Fig. 2

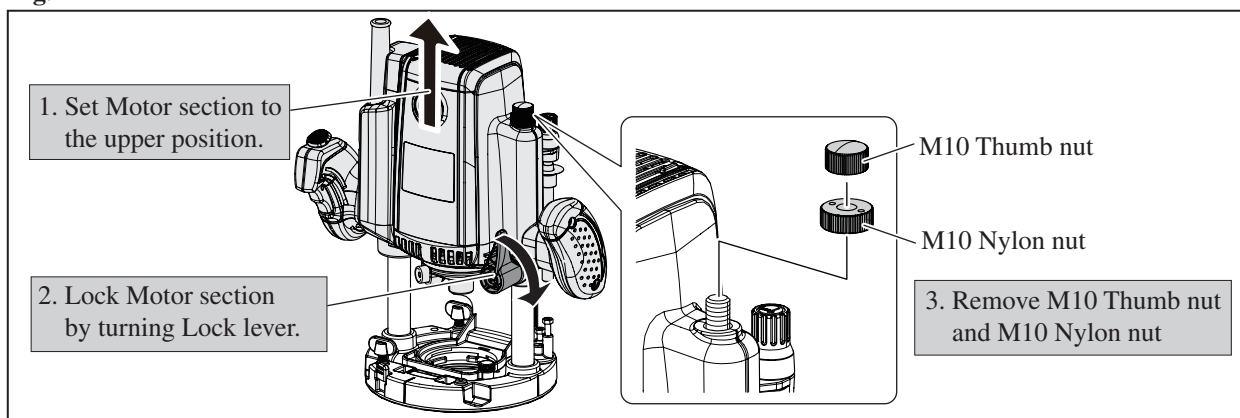

► **Repair**

[3] DISASSEMBLY/ASSEMBLY

[3]-1. Base complete (cont.)

DISASSEMBLING

Fig. 3

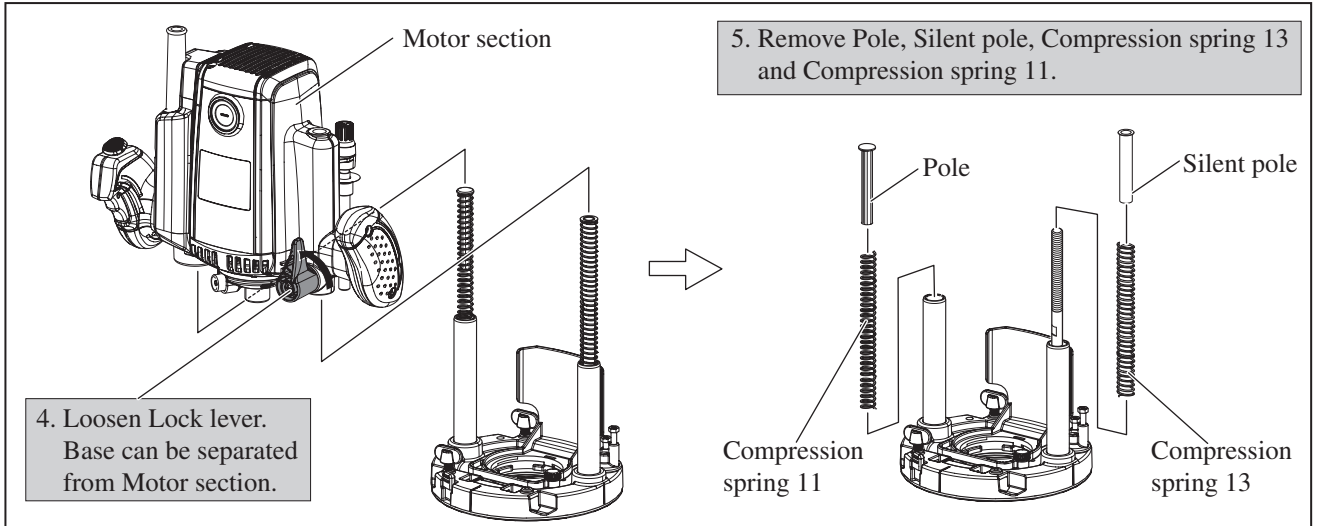

(2) Remove Base plate, Lock plate, Compression spring 4 and other component parts.
Refer to **Figs. 4 and 5.**

Fig. 4

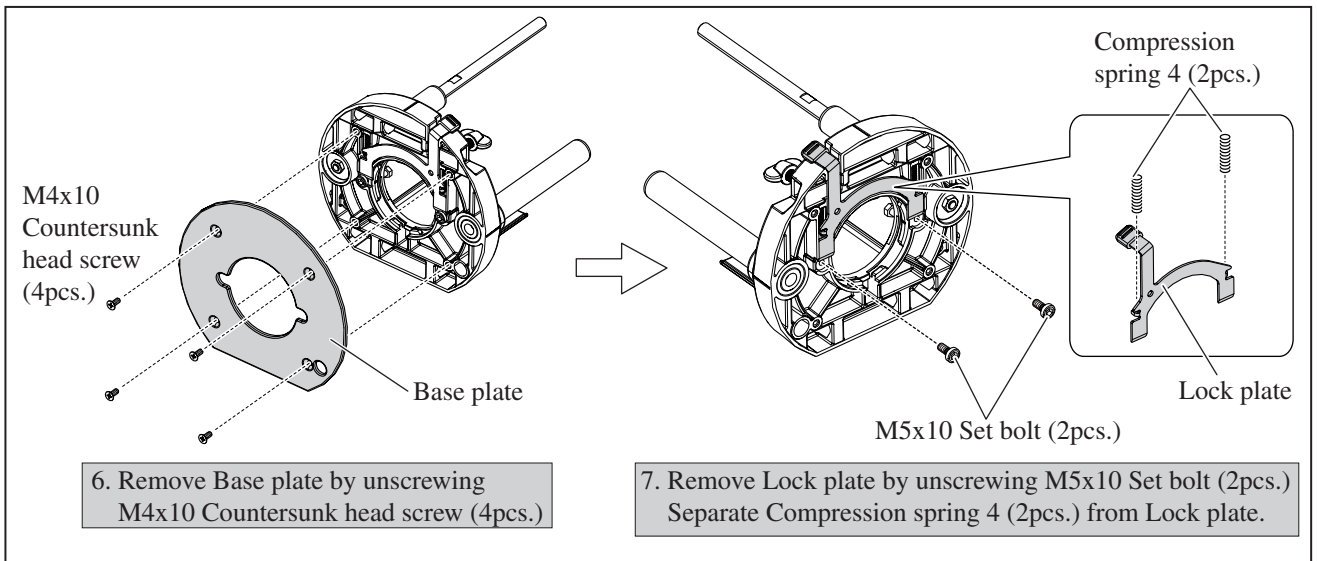
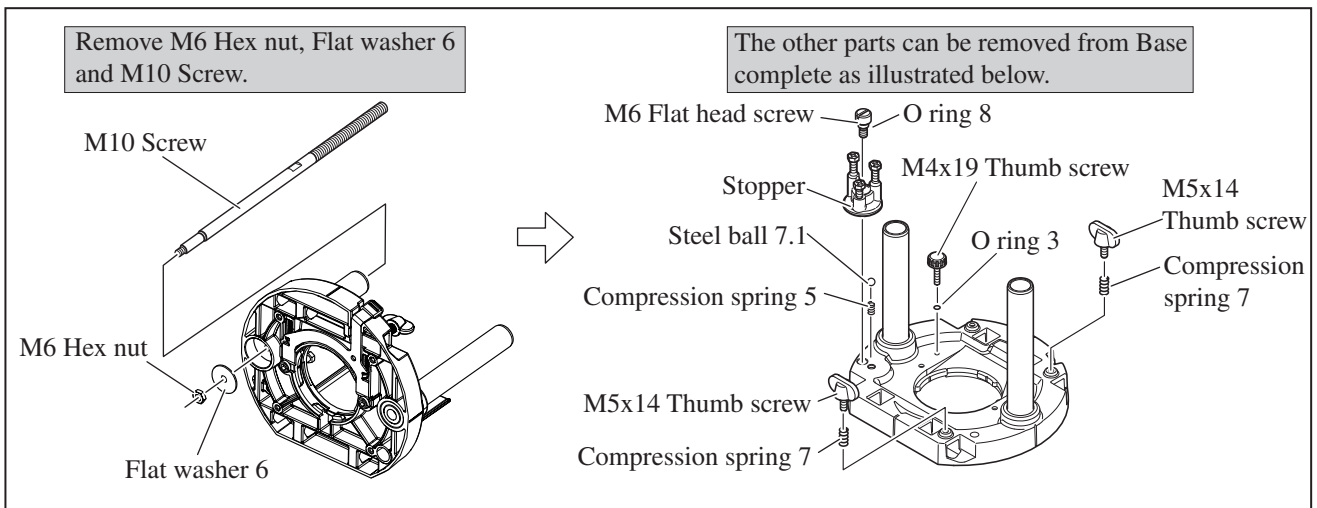

Fig. 5



► **Repair**

[3] DISASSEMBLY/ASSEMBLY

[3]-1. Base complete

ASSEMBLING

Take the disassembling step in reverse.

Note: • Set Compression spring 4 (2pcs.) in the groove on Base complete as illustrated in **Fig. 6**

- M6 - Flat head screw is thread-locker type. When removing it, be sure to apply adhesive (ThreeBond 1321/ 1342 or Loctite 242) to the thread before reusing.
- Assemble Compression spring 11, Compression spring 13, Pole and Silent pole as illustrated in **Fig. 3**.
- Check that two Compression springs 4 work properly by pulling the lever portion of Lock plate after assembling Base plate to Base. Refer to **Figs. 6 and 4**.

Fig. 6

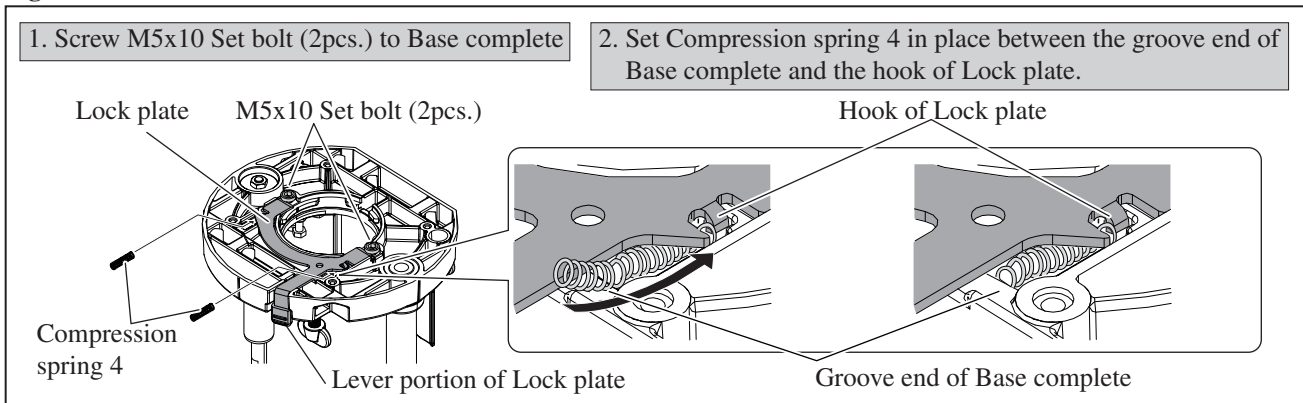

[3]-2. Armature, Motor bracket complete

DISASSEMBLING

- (1) Separate Base section from Motor section as illustrated in **Figs. 2 and 3**.
- (2) Disassemble Armature as illustrated in **Figs. 7, 8, 9, 10, 11, 12 and 13**.

Fig. 7

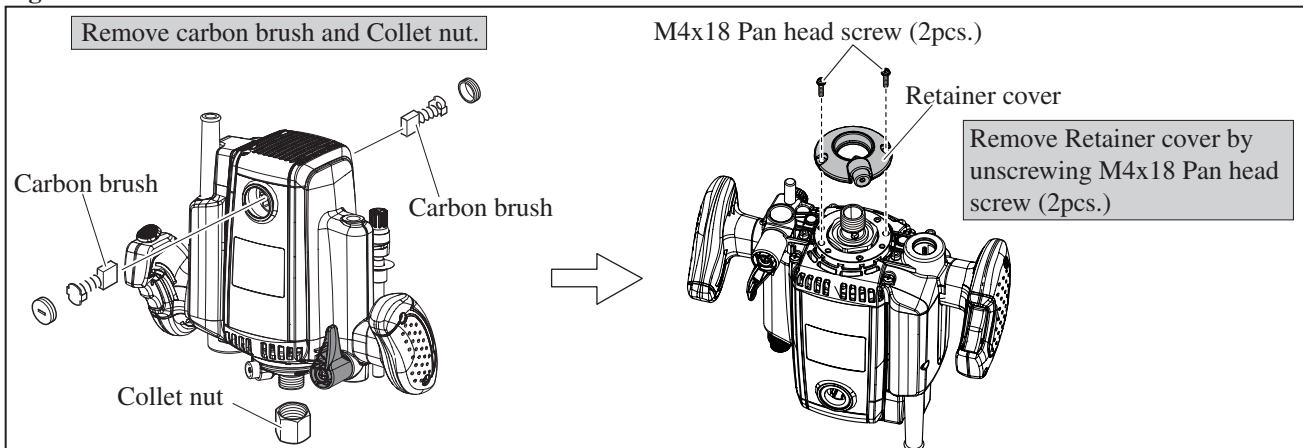
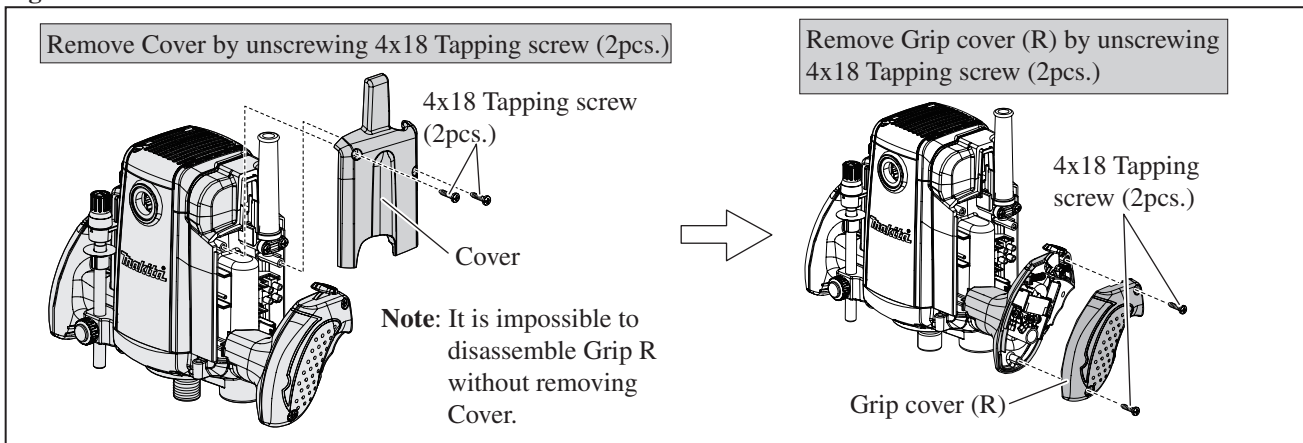

Fig. 8



► **Repair**

[3] DISASSEMBLY/ASSEMBLY

[3]-2. Armature, Motor bracket complete (cont.)

DISASSEMBLING

Fig. 9

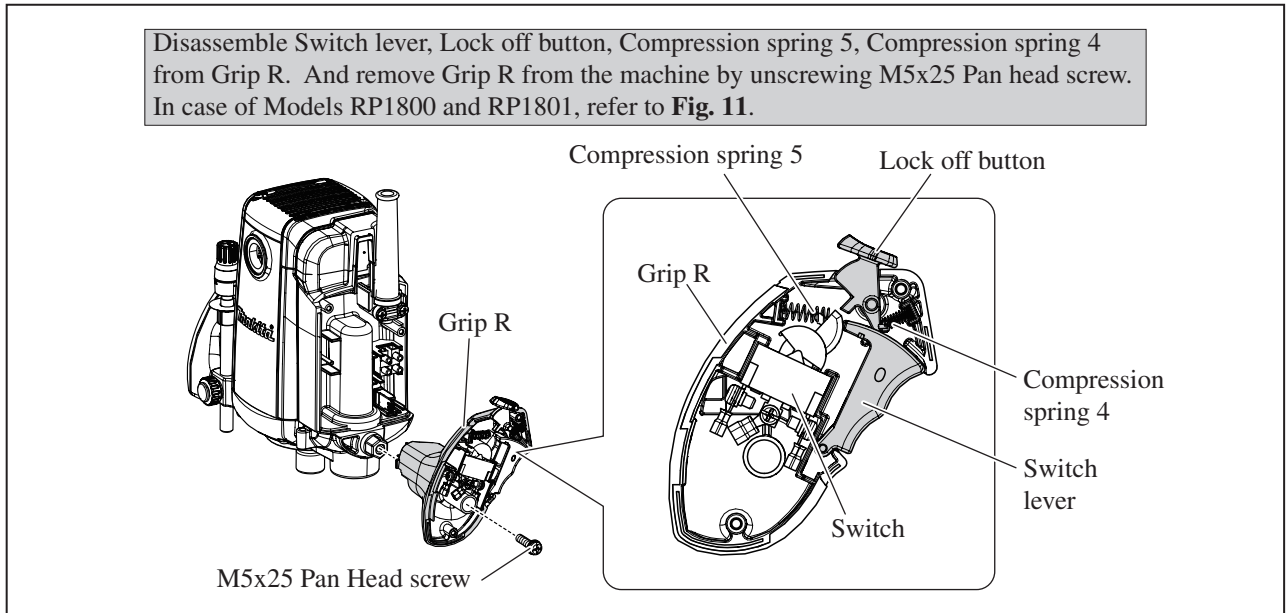

Fig. 10

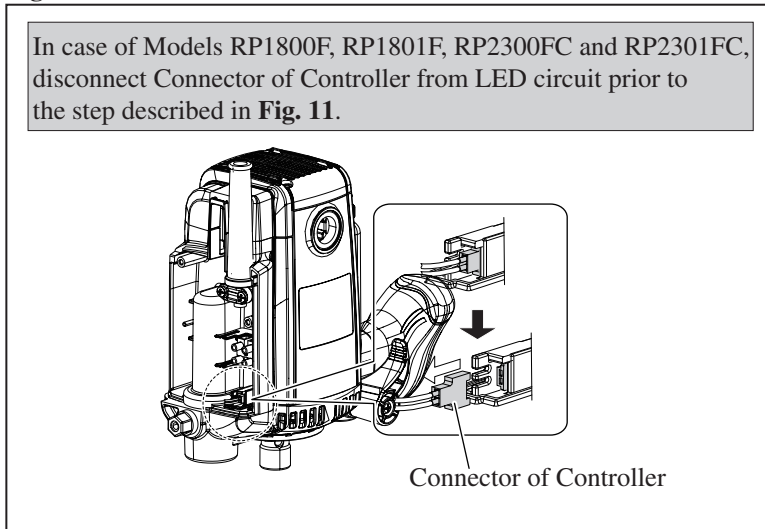

Fig. 11

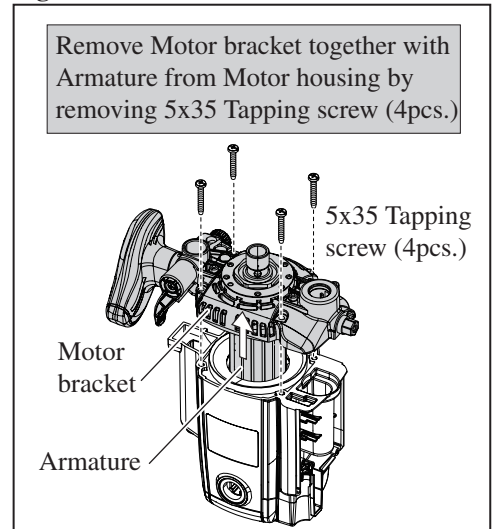
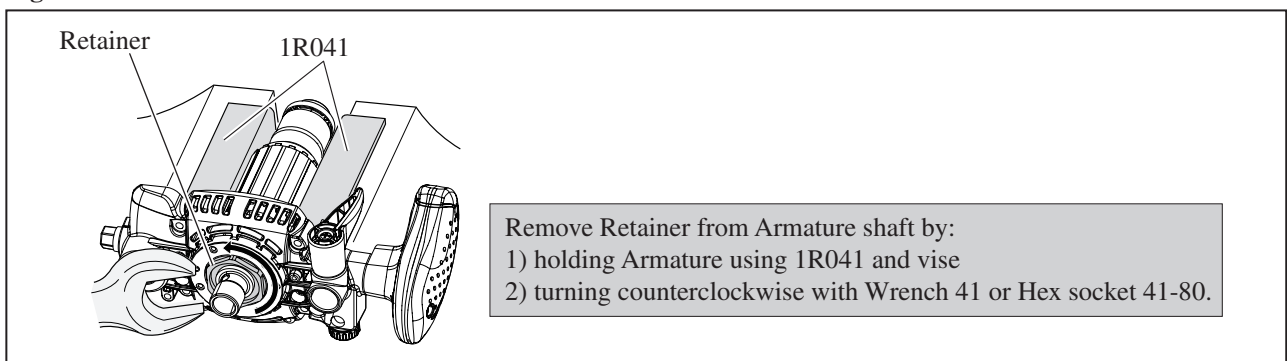

Fig. 12



► **Repair**

[3] DISASSEMBLY/ASSEMBLY

[3]-2. Armature, Motor bracket complete (cont.)

DISASSEMBLING

(3) Armature can be removed in the manner A or B shown in **Fig. 13**. Remove Ball bearing 629DDW from Armature.
Fig. 13

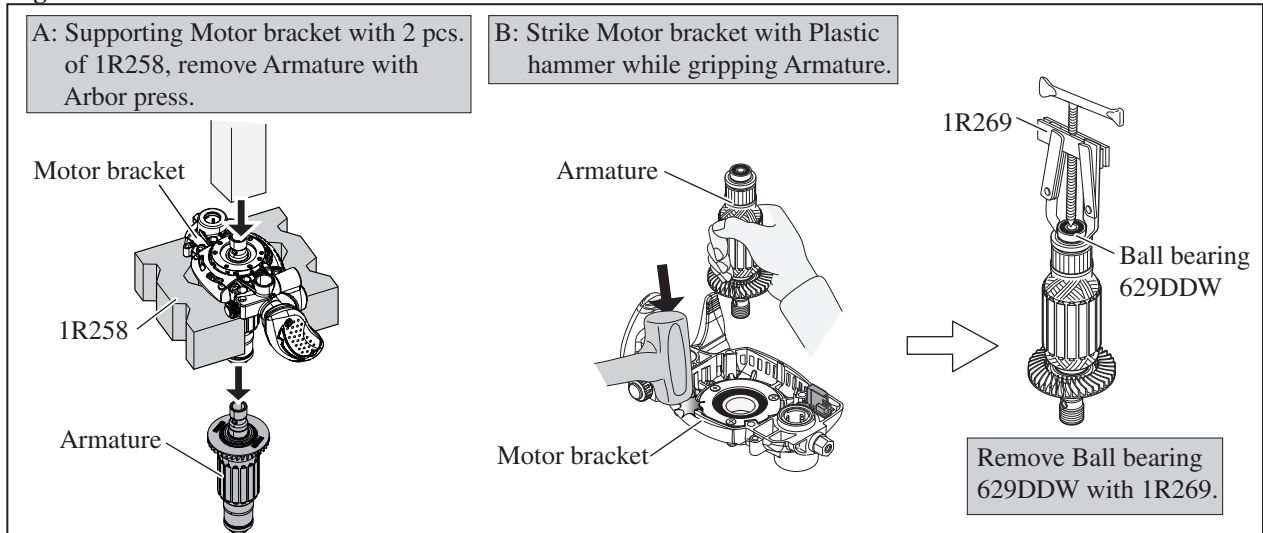

(4) Disassemble the Motor bracket as illustrated in **Figs. 14 and 15**.

Fig. 14

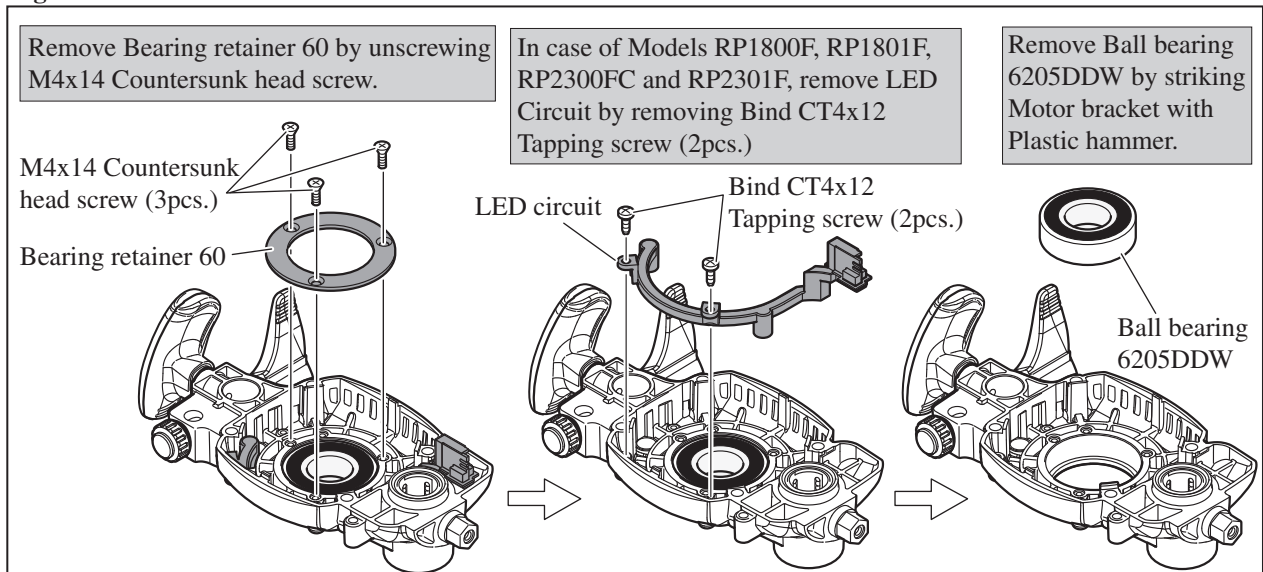
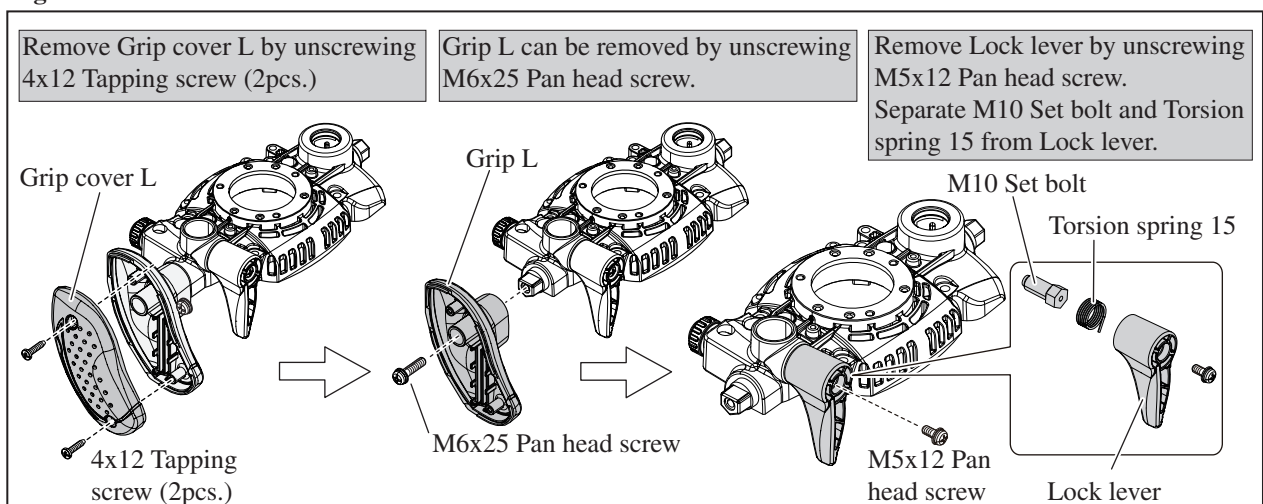

Fig. 15



► **Repair**

[3] DISASSEMBLY/ASSEMBLY

[3]-2. Armature, Motor bracket complete

ASSEMBLING

- (1) Assemble Ball bearing 6205DDW to Motor bracket. Refer to **the right illustration in Fig. 14.**
 - (2) In case of RP1800F, RP1801F, RP2300FC and RP2301FC, secure LED circuit with 4x12 Tapping screw (2pcs.). Refer to **the center illustration in Fig. 14.**
 - (3) Tighten Bearing retainer 60 with M4x14 Countersunk head screw (3pcs.) to secure Ball bearing 6205DDW. Refer to **the left illustration in Fig. 14.**
- Note:** Apply adhesive ThreeBond 1321 / 1342 or Loctite 242 to the threaded portion of M4x14 Countersunk head screw (3pcs.)
- (4) Assemble Lock lever to Motor bracket as illustrated in **Figs. 16, 17 and 18.**

Fig. 16

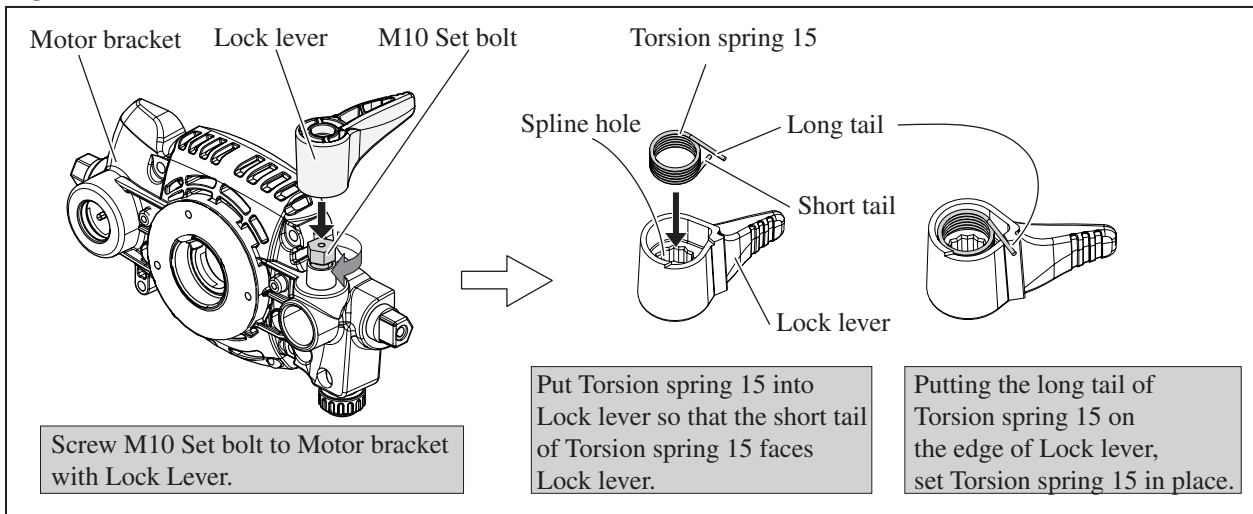

Fig. 17

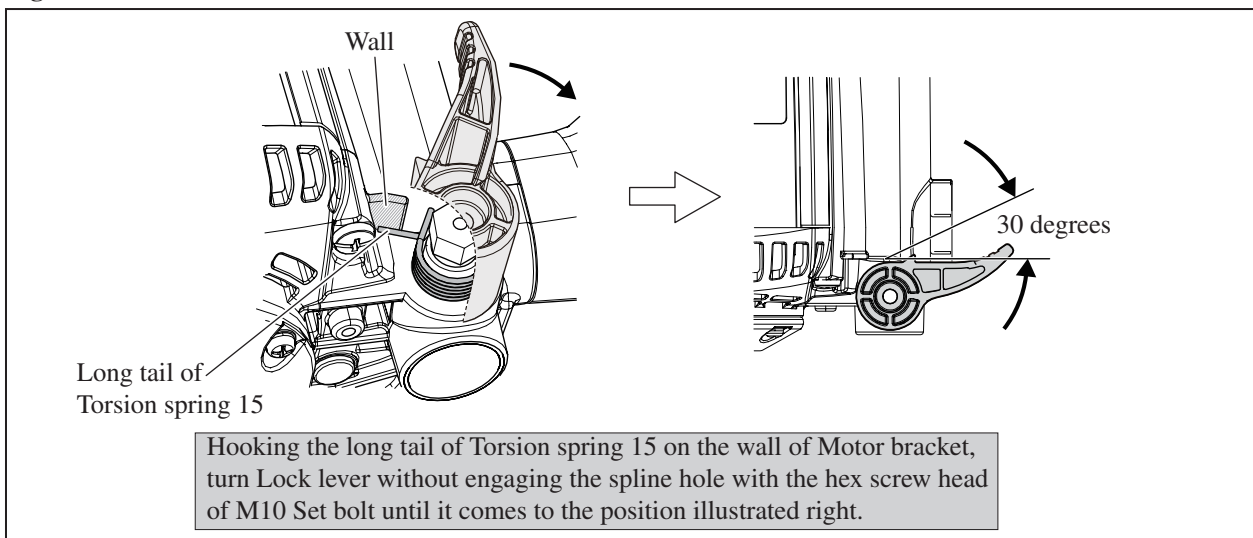
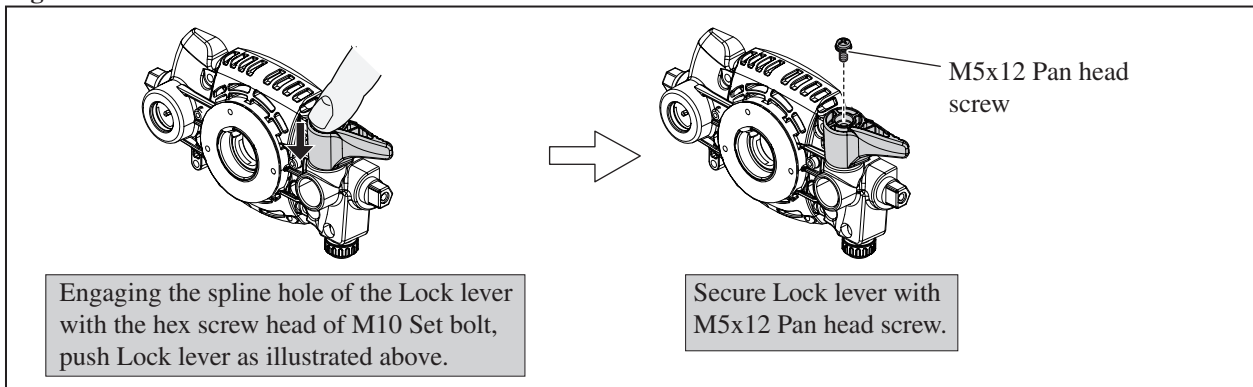

Fig. 18



► Repair

[3] DISASSEMBLY/ASSEMBLY

[3]-2. Armature, Motor bracket complete (cont.)

ASSEMBLING

- (5) Assemble Grip L to Motor bracket on Lock lever side and secure it with M6x25 Pan head screw. Refer to **Fig. 15**.
Assemble Grip cover L to Grip L by screwing two 4x12 Tapping screws. Refer to **Fig. 15**.
- (6) Assemble Armature to Motor bracket. Refer to **Fig. 13**
- (7) Assemble Retainer to Armature shaft by turning with Wrench 41 or Hex socket 41-80 clockwise. Refer to **Fig. 12**.
- (8) Assemble Motor bracket to Motor housing. Refer to **Fig. 11**.
- (8) In case of Models RP1800F, RP1801F, RP2300F, RP2301FC, connect LED circuit. Refer to **Fig. 10**.
- (9) Assemble Grip R section to Motor bracket. Refer to **Fig. 9**.
- (10) Secure Grip cover (R) with two 4x18 Tapping screws to the Grip R. Refer to **right** illustration in **Fig. 8**.
And assemble Cover to Motor housing. Refer to **left** illustration in **Fig. 8**.
- (11) Mount Retainer cover to Motor bracket. Refer to **right** illustration in **Fig. 7**. And assemble Carbon brushes and Collet nut. Refer to **left** illustration in **Fig. 7**.

[3]-3. Shaft Lock

DISASSEMBLING

- (1) Separate Base section from Motor section as illustrated in **Figs. 2, 3**.
- (2) Remove Retainer cover by unscrewing two M4x18 Pan head screws as the **right** illustration in **Fig. 7**.
- (3) Shaft lock mechanism can be disassembled as illustrated in **Fig. 19**.

Fig. 19

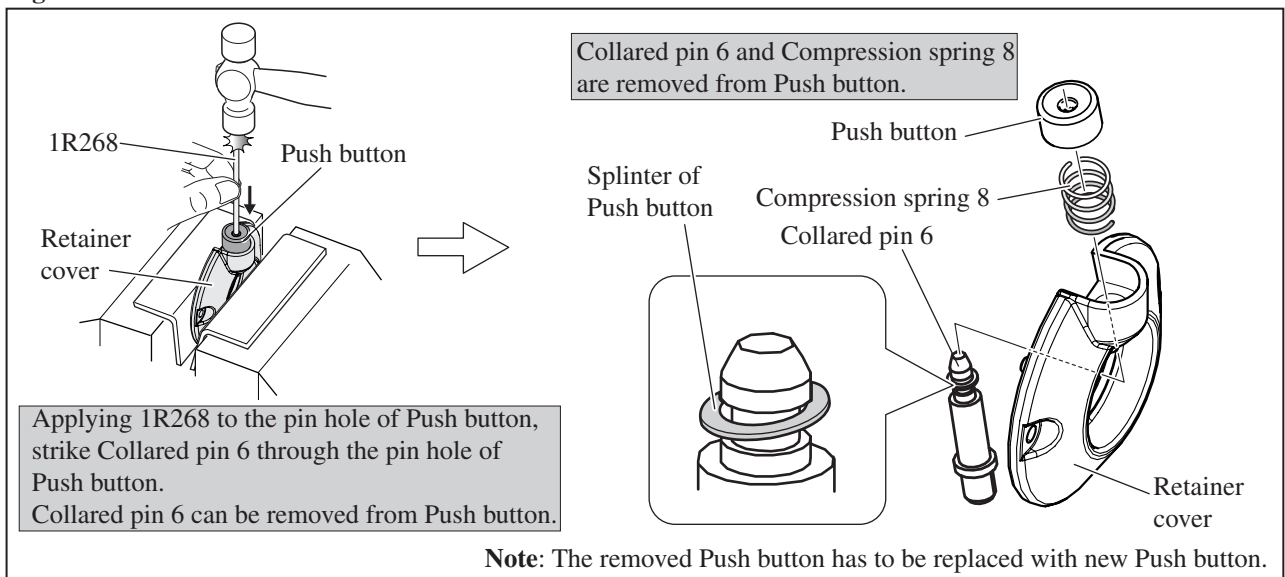

ASSEMBLING

Shaft lock section can be assembled as illustrated in **Fig. 20**.



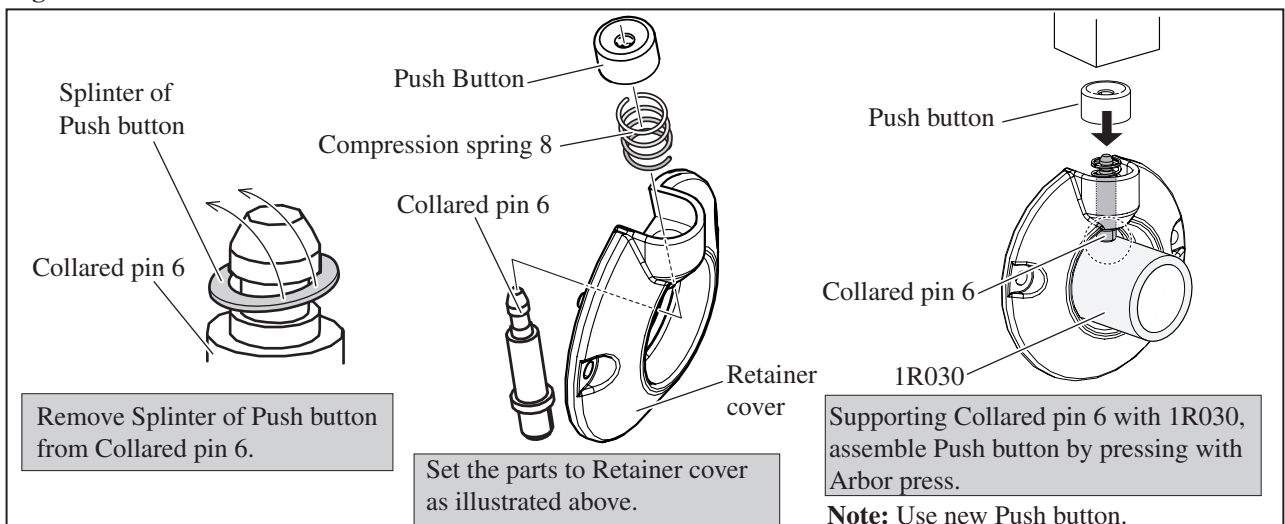
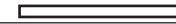



Fig. 20



▶ **Circuit diagram**

Fig. D-1A

RP2301FC with electric Brake, LED Job Light, Electronic Control

Color index of lead wires' sheath			
Black		Purple	
White		Yellow	
Orange		Red	

* Support unit without Choke coil is used for some countries.

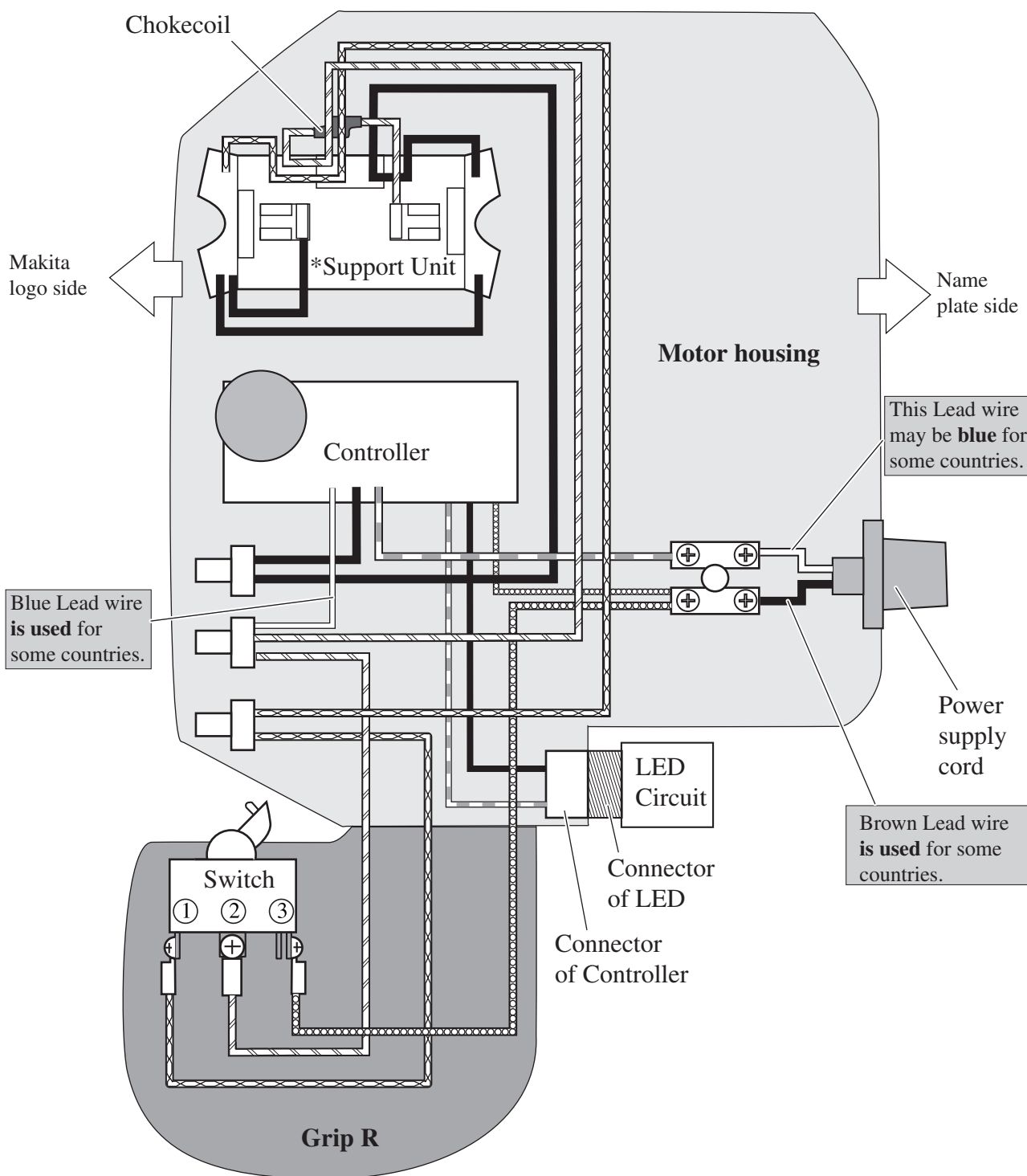

► **Wiring diagram**

Fig. D-2A

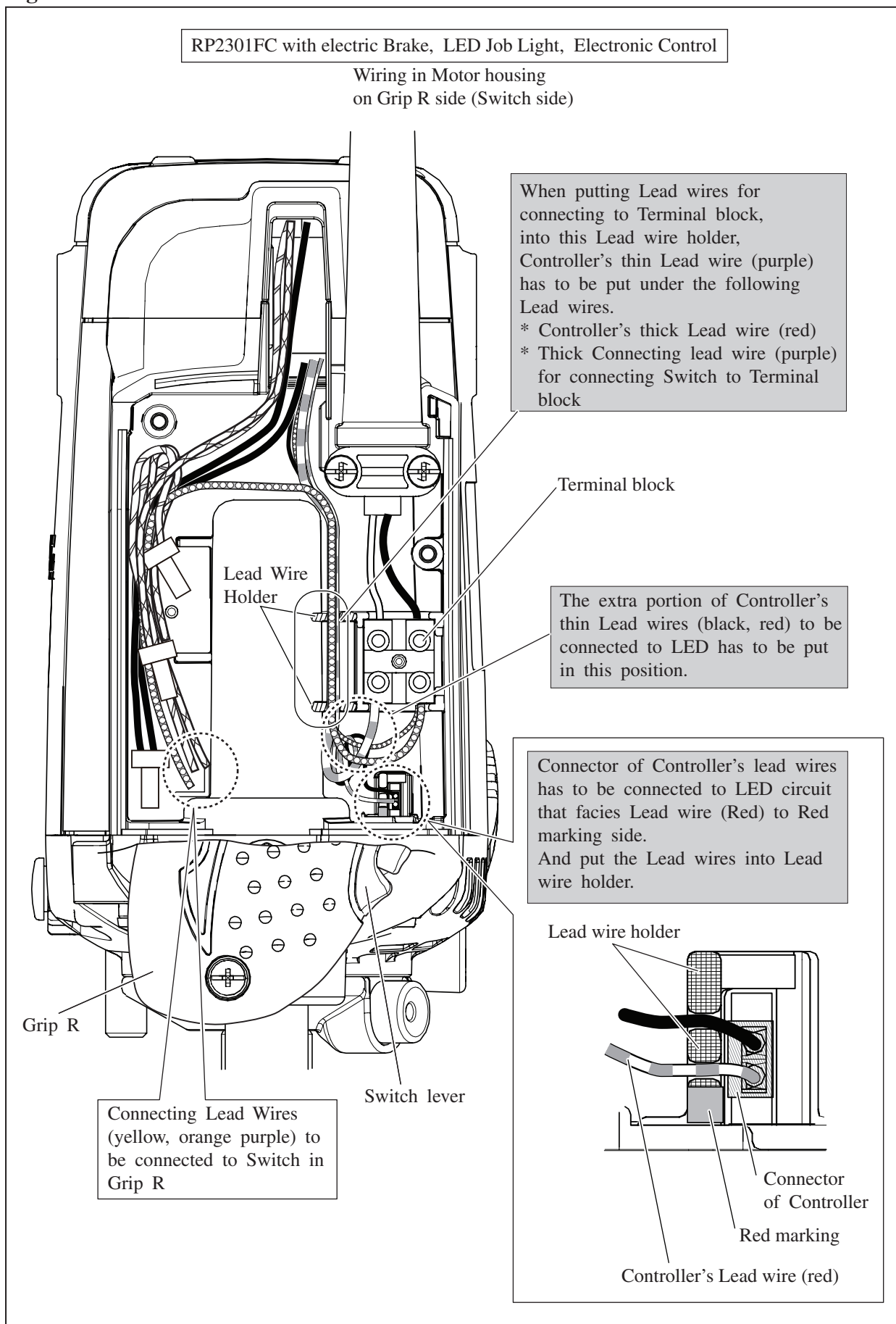

▶ **Wiring diagram**

Fig. D-3A

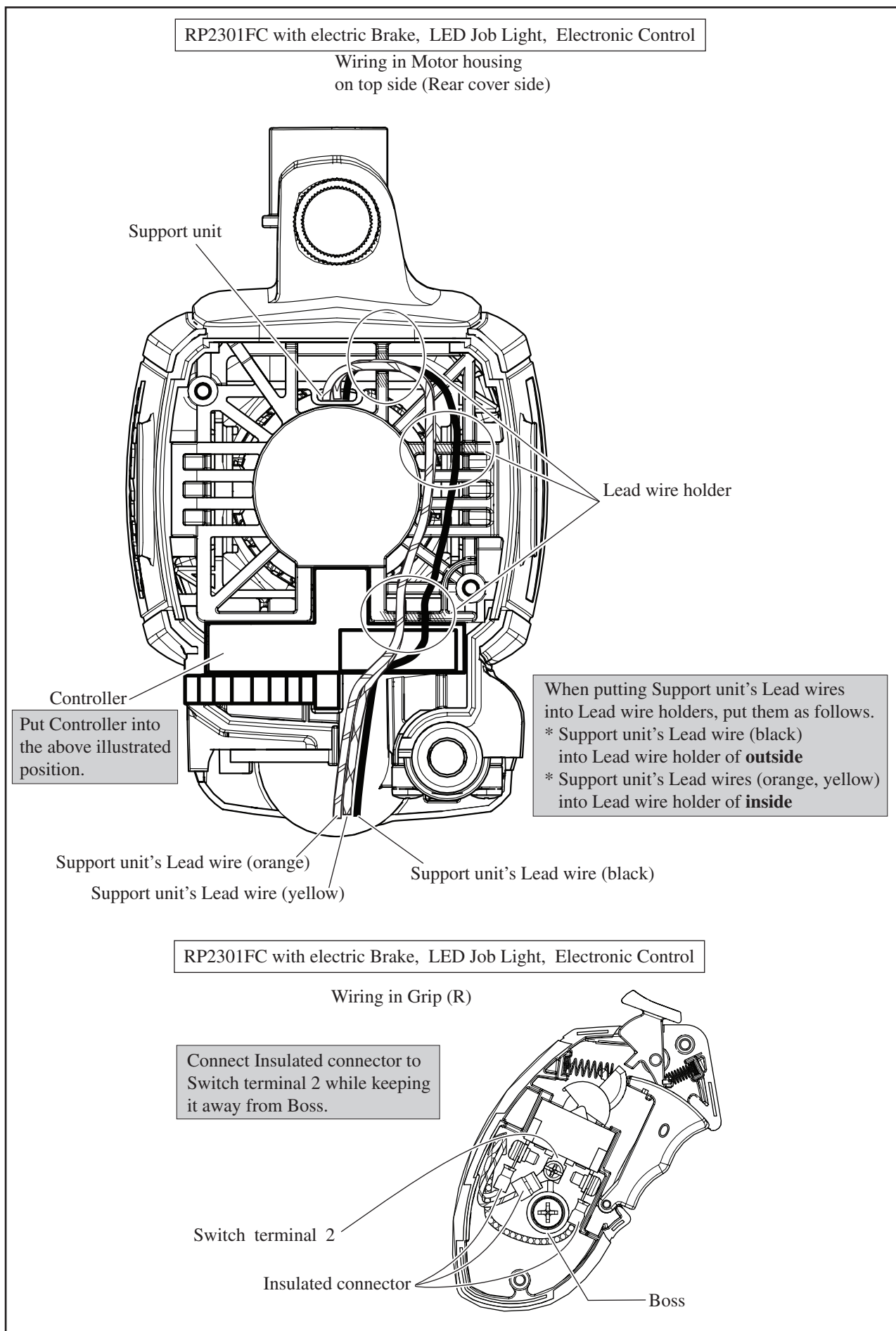

► **Circuit diagram**

Fig. D-1B

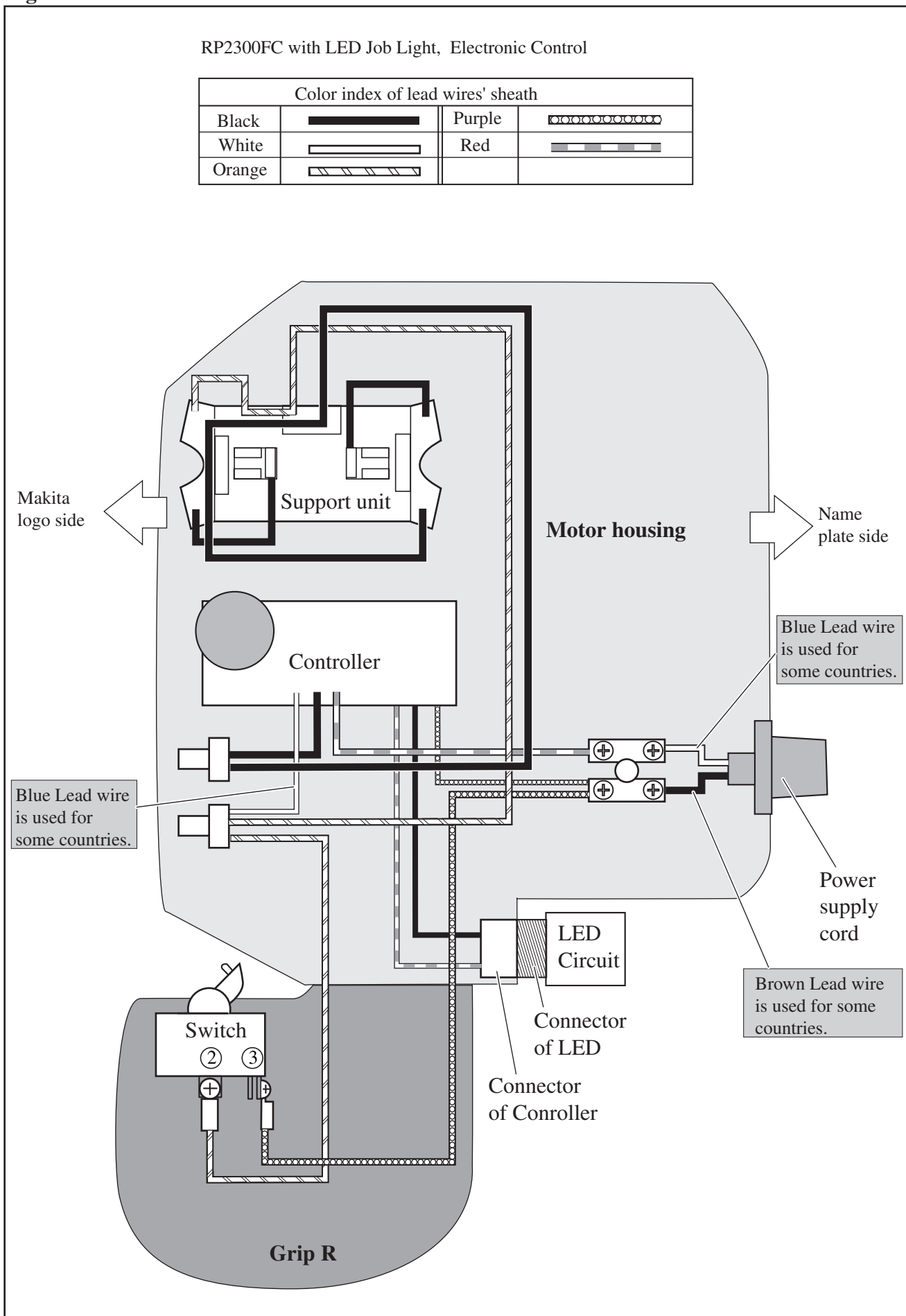

► **Wiring diagram**

Fig. D-2B

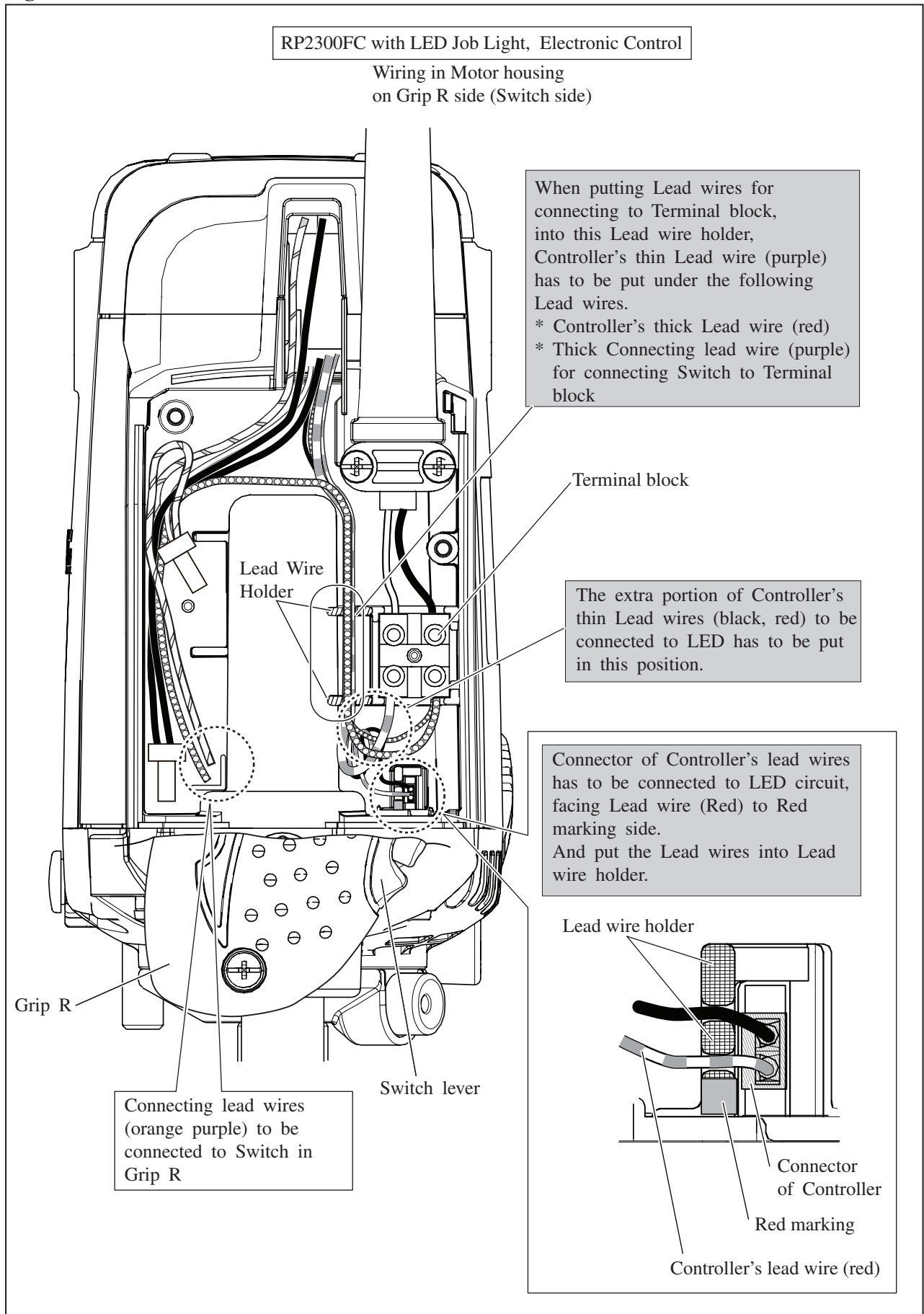

▶ **Wiring diagram**

Fig. D-3B

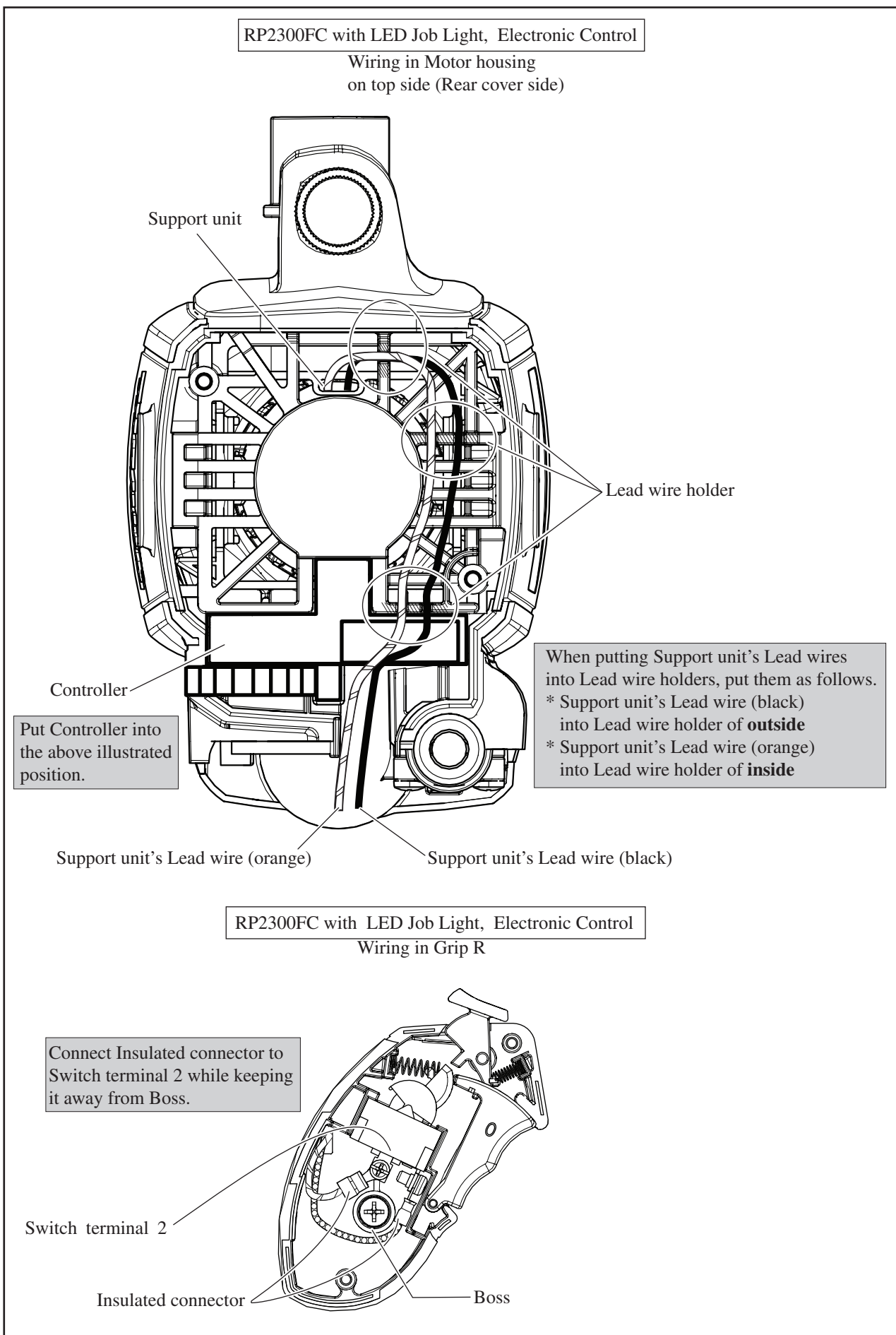

► **Circuit diagram**

Fig. D-1C

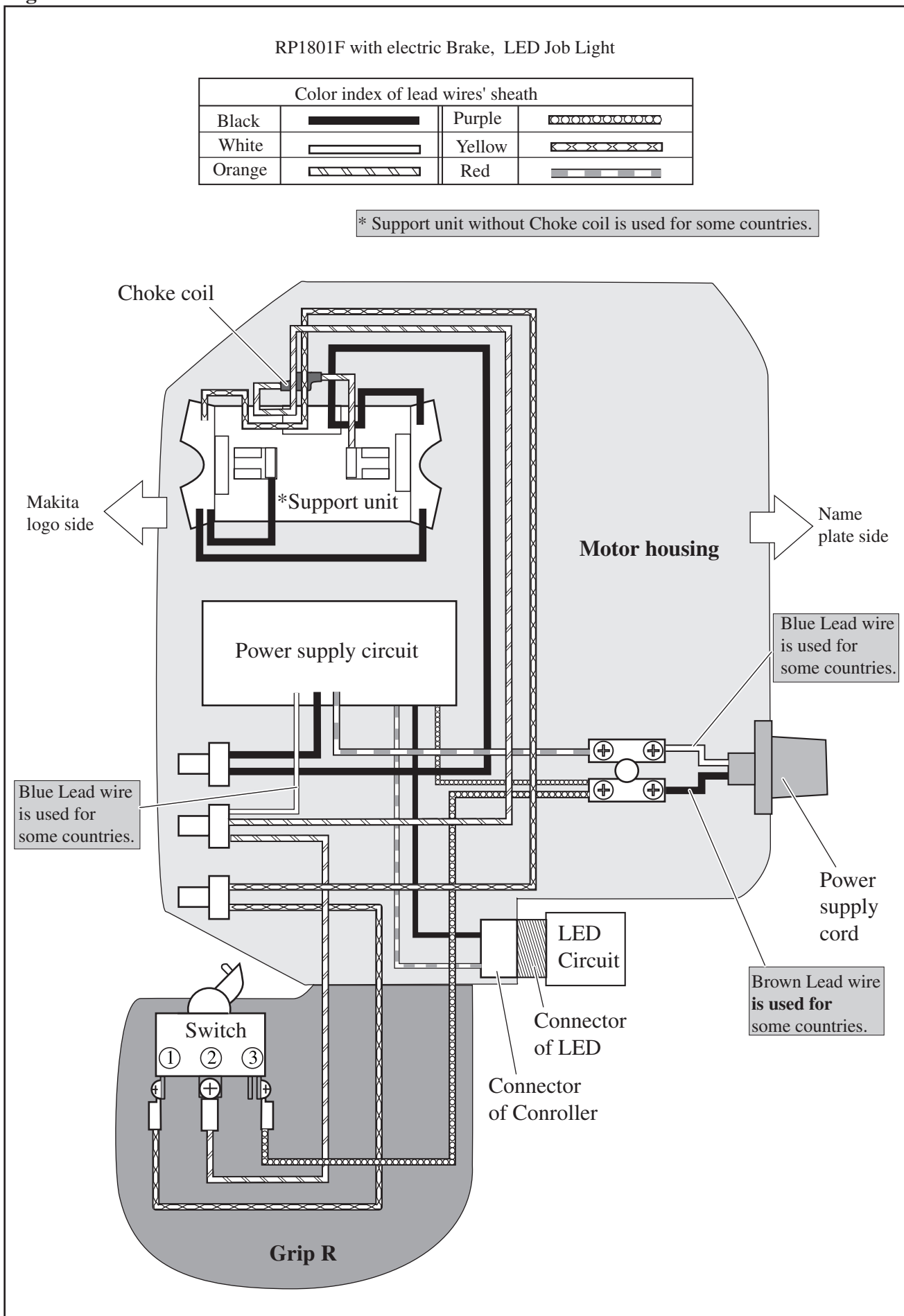

► **Wiring diagram**

Fig. D-2C

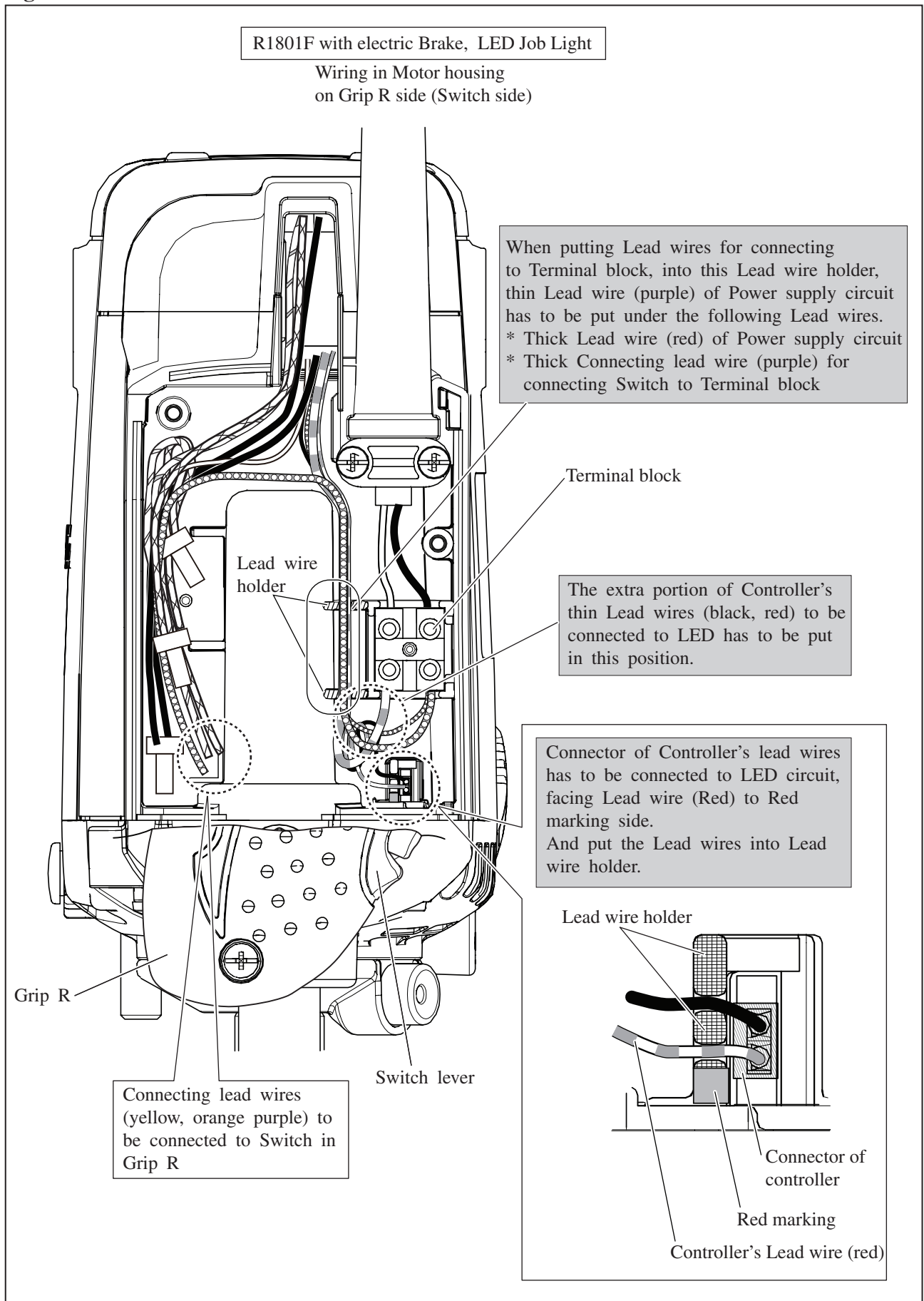

▶ **Wiring diagram**

Fig. D-3C

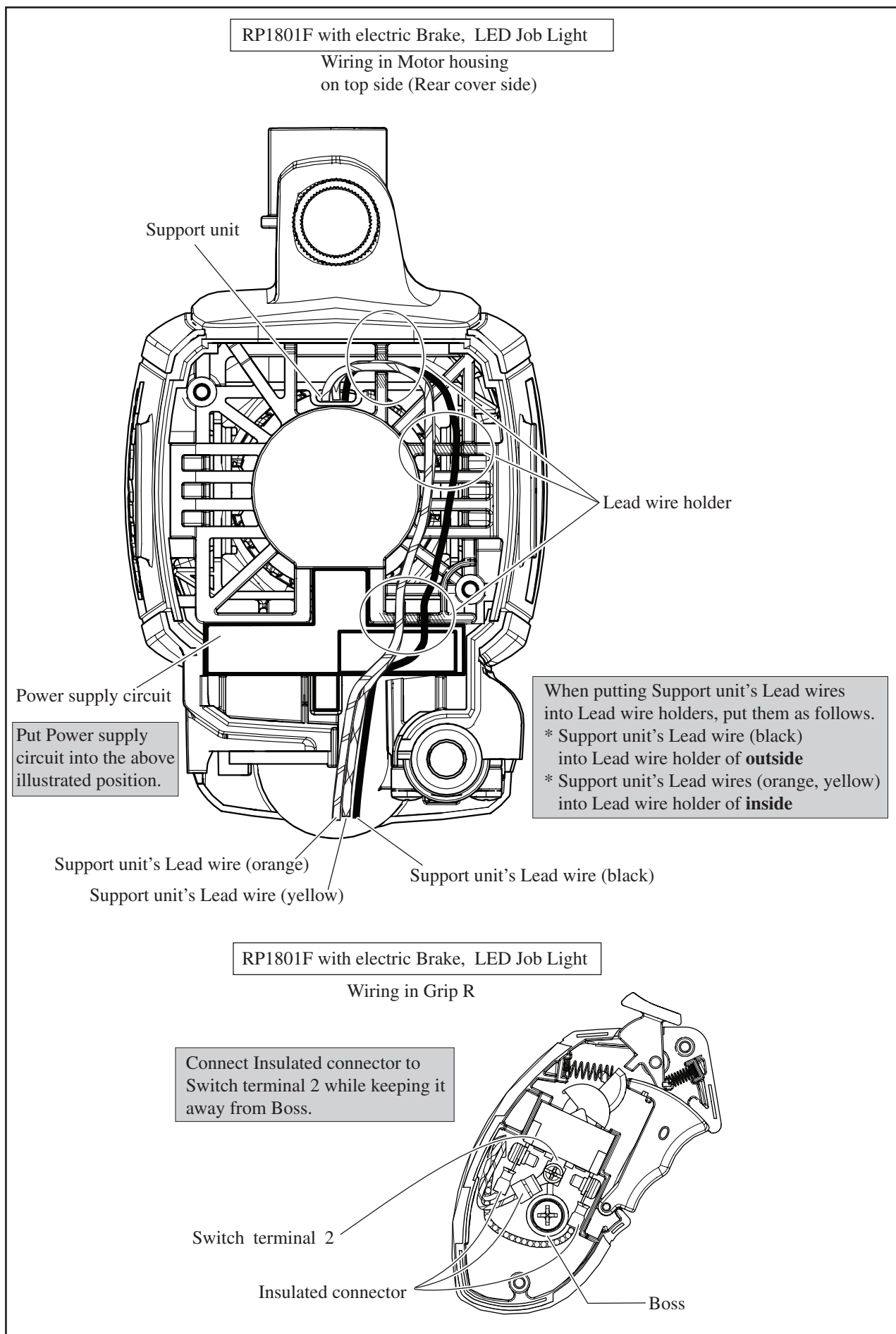

▶ **Circuit diagram**

Fig. D-1D

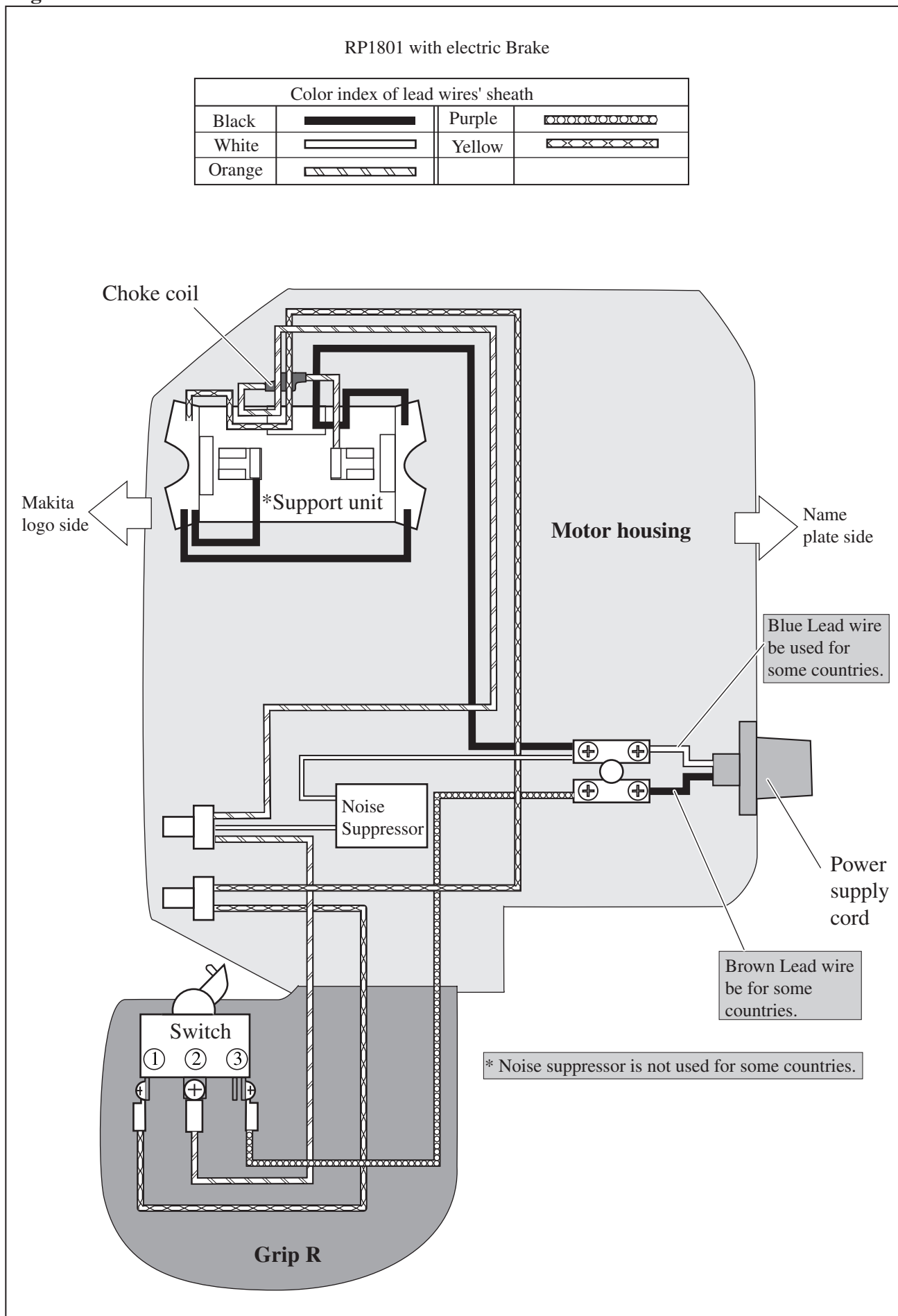

► **Wiring diagram**

Fig. D-2D

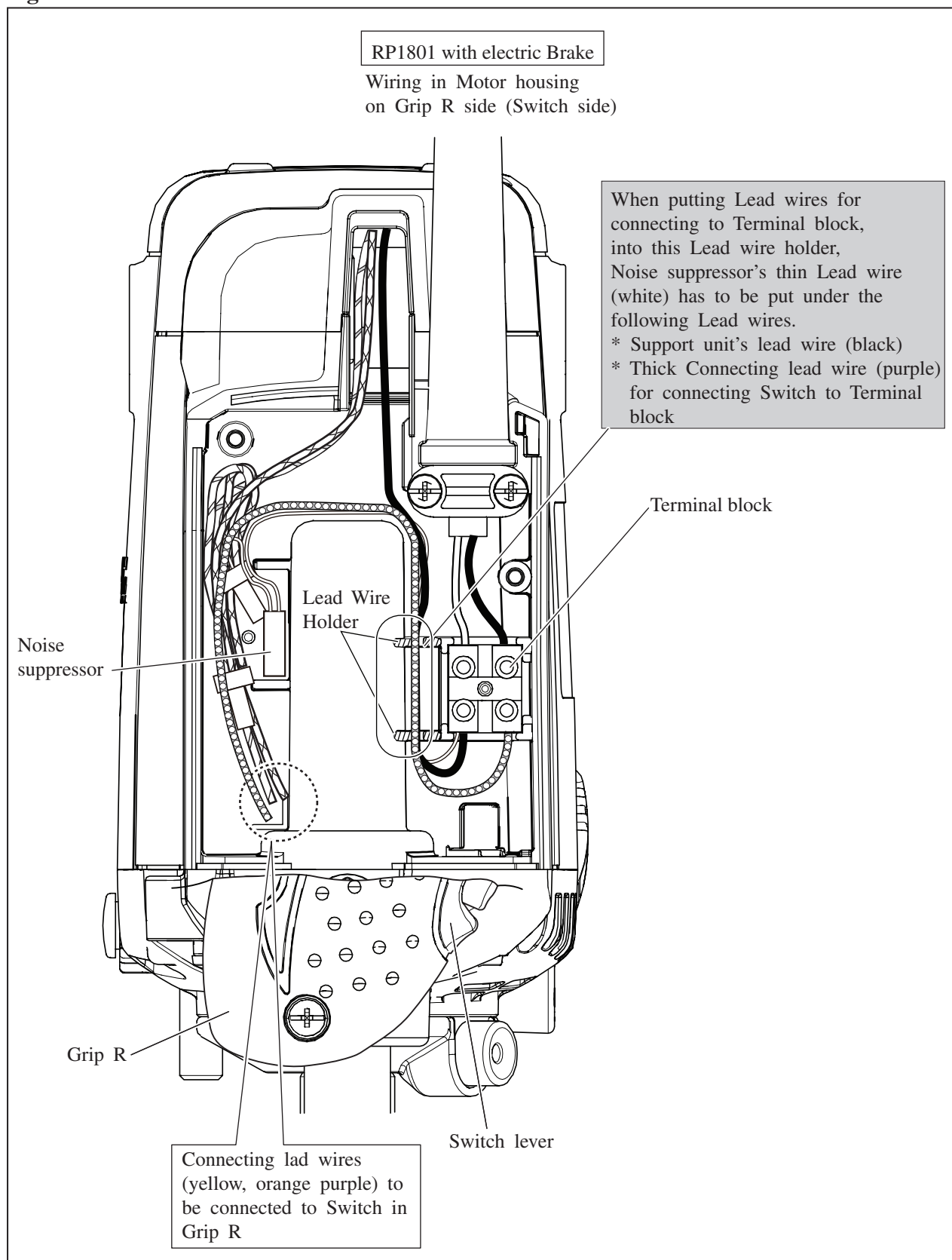

▶ **Wiring diagram**

Fig. D-3D

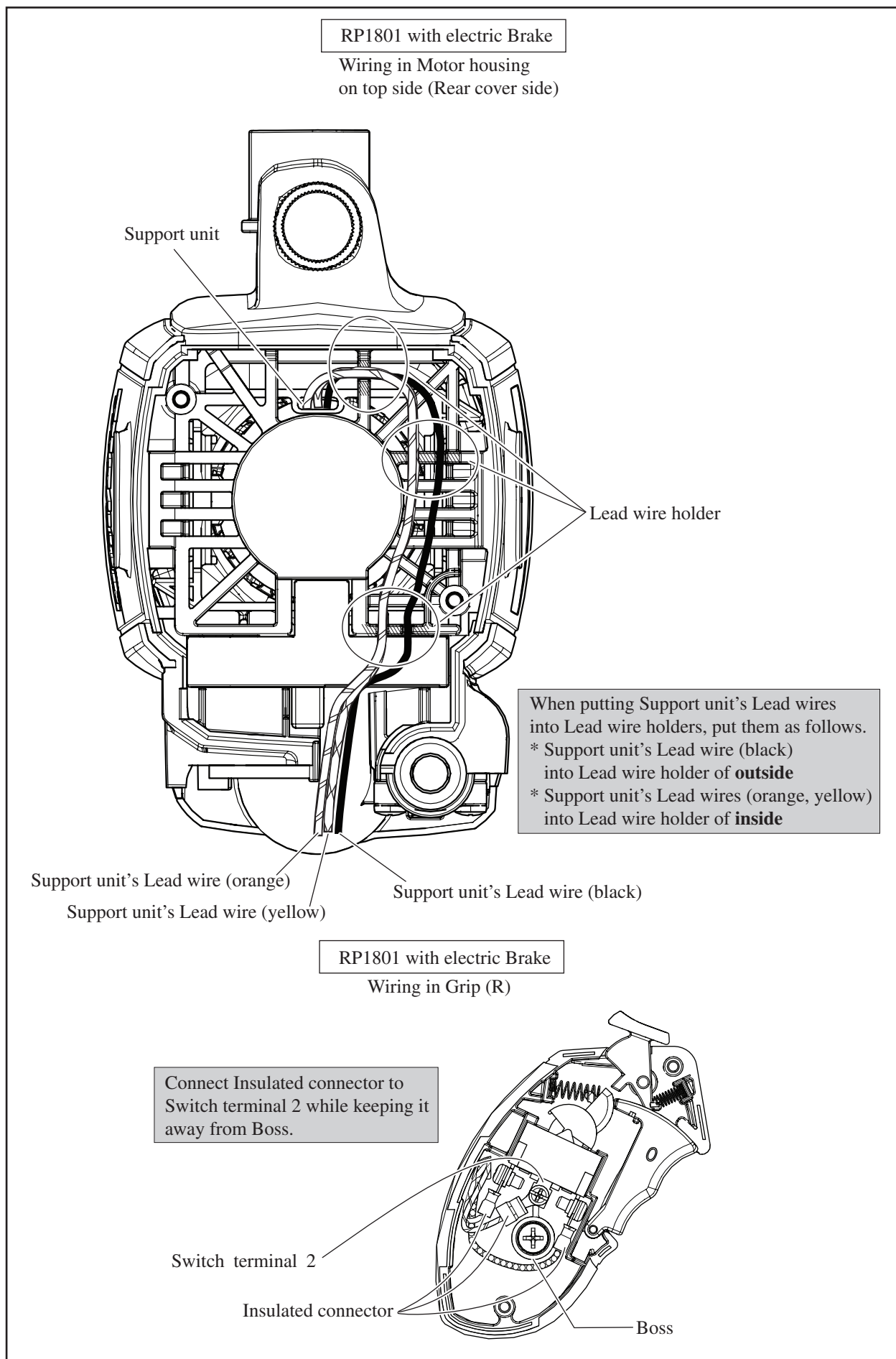

► **Circuit diagram**

Fig. D-1E

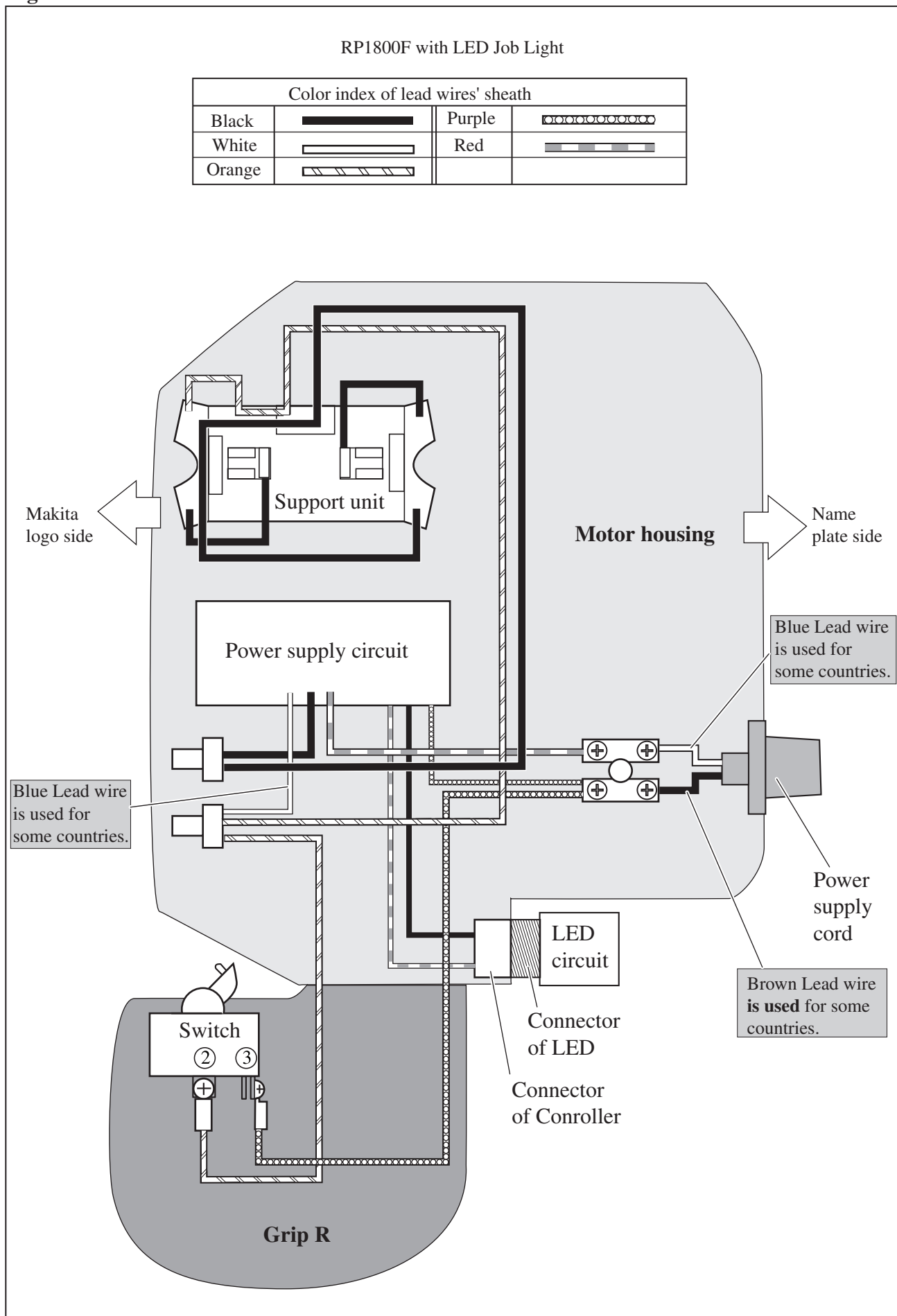

► **Wiring diagram**

Fig. D-2E

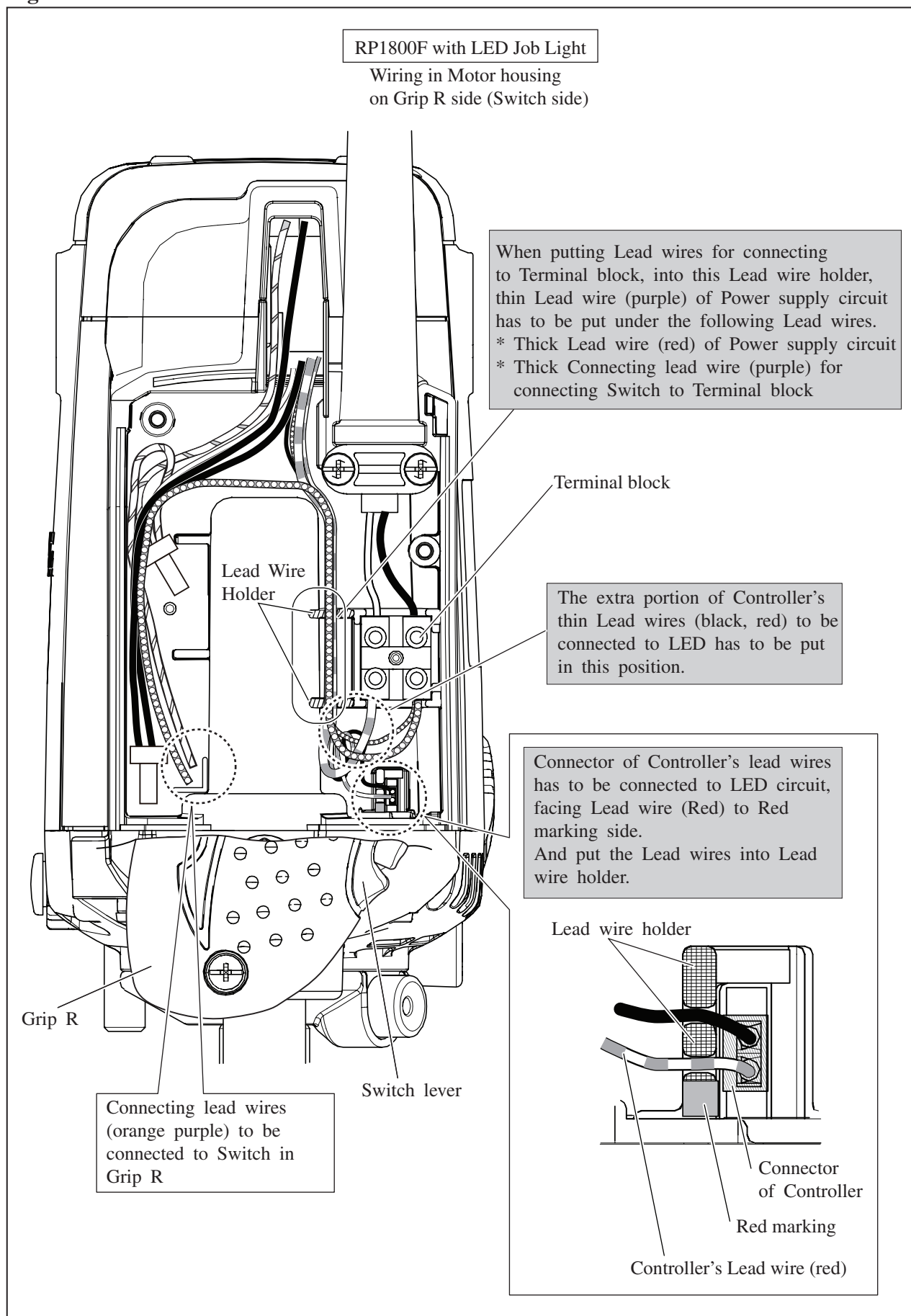

▶ **Wiring diagram**

Fig. D-3E

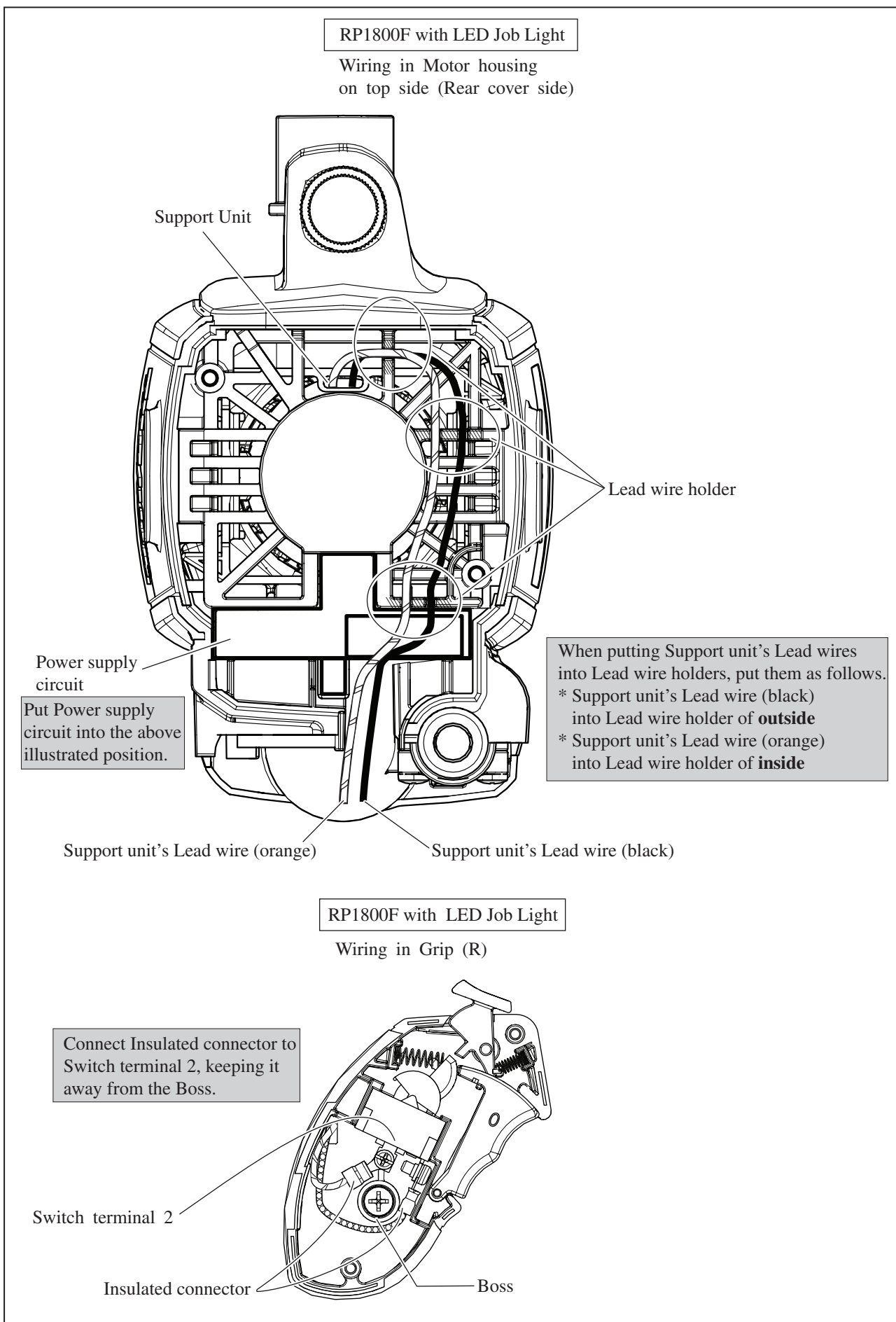

▶ **Circuit diagram**

Fig. D-1F

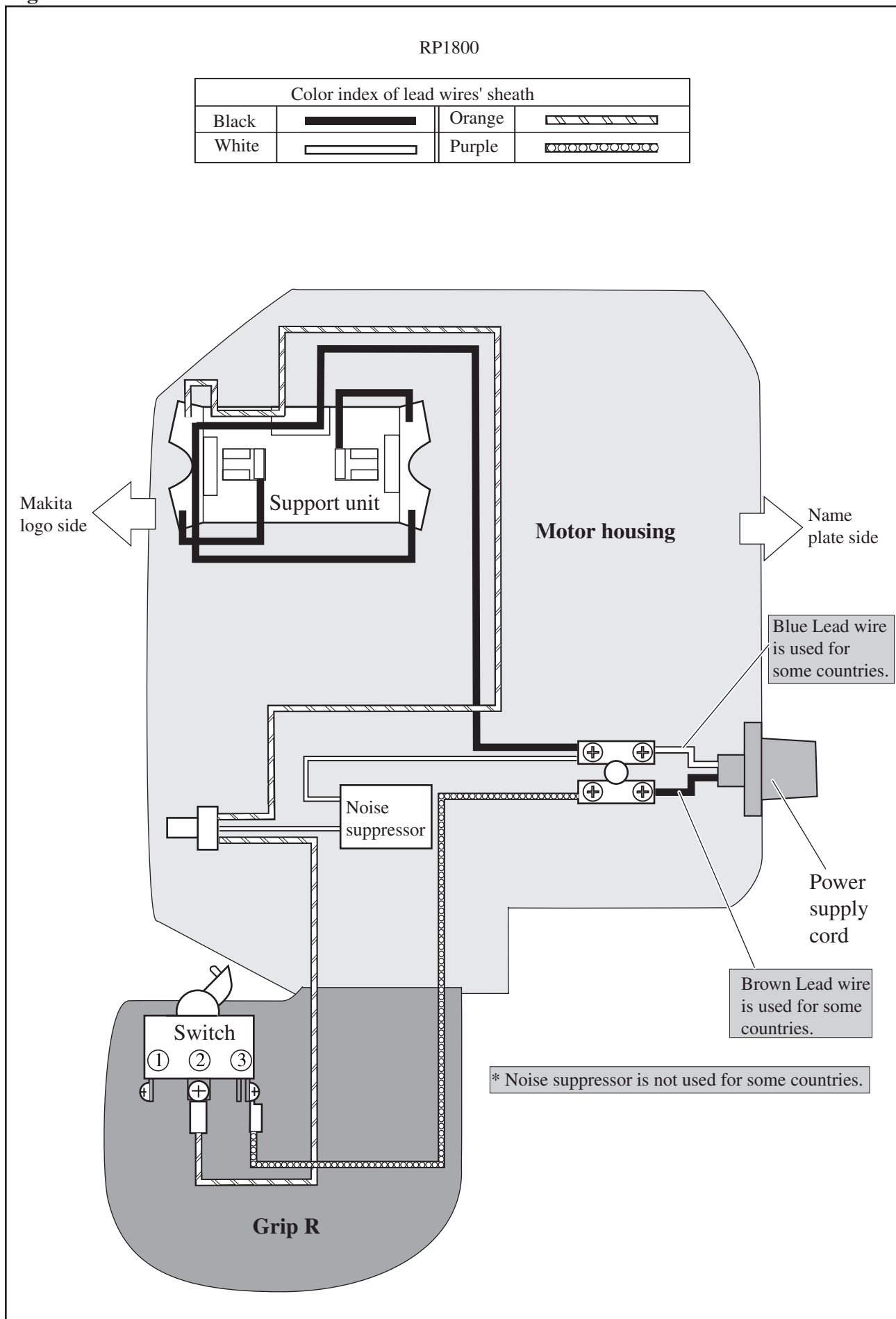

► Wiring diagram

Fig. D-2F

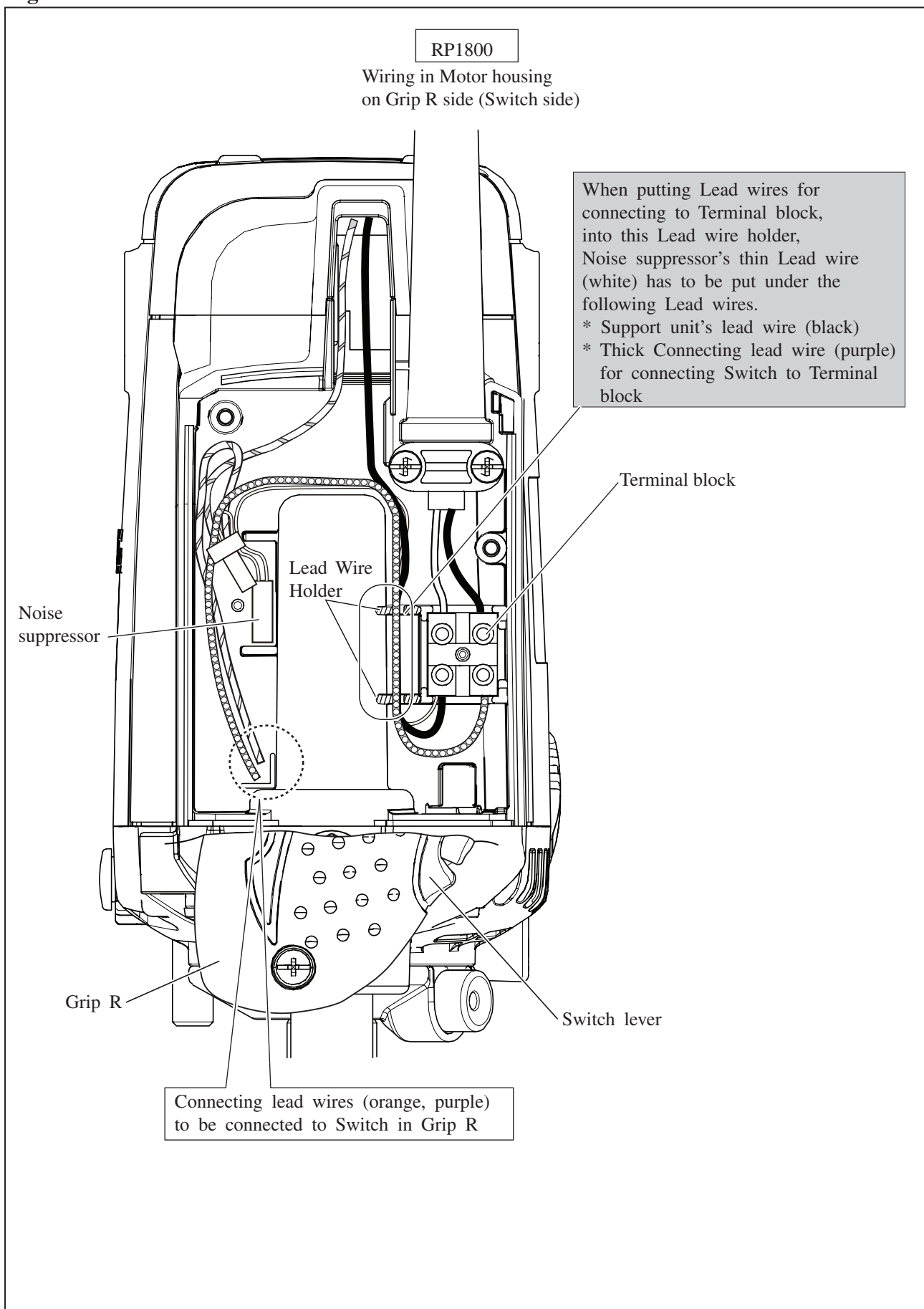

▶ Wiring diagram

Fig. D-3F

