

TECHNICAL INFORMATION



PRODUCT

P 1 / 19

- Models No.** ▶ HM1317C/ HM1307C
HM1317CB/ HM1307CB
- Description** ▶ Electric Breaker

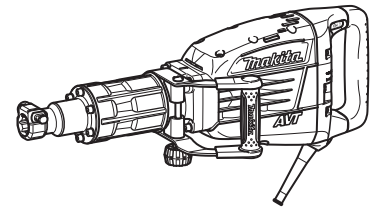

[The image above is HM1317C.]

CONCEPT AND MAIN APPLICATIONS

HM1317C series models are 15kg-class Hex shank demolition hammers with the following main features:

- Same high maneuverability as the current models HM1304/ HM1304B
- High durability obtained by strengthening barrel, gears, etc
- AVT* for reduced vibration during chipping
- Suppression of motor speed during no-load for reduced vibration when idling

Described in the table below are the specification differences between the four models in the subject.

	Shank type	AVT*	Vibration absorbing handle	Constant speed control	Suppression of motor speed during no-load
HM1317C	30mm Hex	Yes	No	Yes	Yes
HM1307C		No			No
HM1317CB	28.6mm Hex	Yes			Yes
HM1307CB		No			No

*Anti-Vibration Technology using Active dynamic vibration absorber

Dimensions: mm (")		
	HM1317C HM1307C	HM1317CB HM1307CB
Length (L)	715 (28-1/8)	824 (32-1/2)
Width (W)	129 (5-1/8)	
Height (H)	266 (10-1/2)	

*HM1307C and HM1307CB do not have "AVT" logotype.

Specification

Voltage (V)	Current (A)	Cycle (Hz)	Continuous Rating (W)		Max. Output (W)
			Input	Output	
110	15	50/60	1,510	700	1,600
120	14	50/60	---	700	1,600
220	8.0	50/60	1,510	800	1,800
230	8.0	50/60	1,510	800	1,800
240	8.0	50/60	1,510	800	1,800

Specifications	Model	HM1317C/ HM1307C	HM1317CB/ HM1307CB
Impacts per min: min-1=ipm		730 - 1,450	
Shank type		Hex	
Shank diameter: mm (")		30 (1-3/16)	28.6 (1-1/8)
Vibration absorption	AVT (Anti-Vibration Technology using Active dynamic vibration absorber)	Yes/ No	Yes/ No
	Vibration absorbing handle	No	
Electronic control	Variable speed control by dial	Yes	
	Soft start	Yes	
	Constant speed control	Yes	
	Suppression of motor speed during no-load	Yes/ No	Yes/ No
Double insulation		Yes	
Power supply cord: m (ft)		Europe, South Africa, Kuwait, Hong Kong, Cyprus: 4.0 (13.1) Brazil: 2.0 (6.6) Other countries: 5.0 (16.4)	
Net weight*: kg (lbs)		17.0/ 15.3 (37.5/ 33.8)	19.0/ 17.3 (41.9/ 38.2)

* Weight according to EPTA-Procedure 01/2003

Standard equipment

Side handle 1 Bull point 1 Plastic carrying 1

Note: The standard equipment for the tool shown above may vary by country.

Optional accessories

Bull points, Cold chisels, Scaling chisels, Clay spade, Rammer, Grease vessel (containing 30g hammer grease), Safety goggles, Hammer service kit

► **Repair**

CAUTION: Repair the machine in accordance with “Instruction manual” or “Safety instructions”.

[1] NECESSARY REPAIRING TOOLS

Code No.	Description	Use for
1R003	Retaining ring S pliers ST-2N	Removing Ring spring 55 from Cylinder
1R023	Pipe ring (for Arbor press)	Supporter when removing Cylinder section with 1R263
1R022/ 356	Bearing plate (for Arbor press)	Pressing down Sleeve when removing Ring spring 55 from Cylinder
1R031	Bearing setting pipe 28-20.2	Assembling Helical gear 47 to Crank shaft
1R045	Gear extractor (large)	Removing Counter shaft
1R258	V block	Assembling Helical gear 47 to Crank shaft
1R212	Tip for Retaining ring pliers	Attachment for 1R003
1R217	Ring 22	Supporting Crank housing
1R228	1/4” Hex shank bit for M4	Unscrewing / Screwing M4 Hex socket head bolts
1R230	1/4” Hex shank bit for M6	Unscrewing / Screwing M6 Hex socket head bolts
1R231	1/4” Hex shank bit for M8	Unscrewing / Screwing M8 Hex socket head bolts
1R246	Round bar for arbor 18-100	Removing Crank shaft from Helical gear 47
1R252	Round Bar for arbor 30-100	Supporting Crank shaft when assembling Helical gear 47
1R263	Bearing extractor	Removing Cylinder section
1R269	Bearing extractor	Removing Ball bearing of Commutator side
1R348	Spring pin 8 remover	Removing Spring pin 8-40 from Tool retainer for HM1307CB, HM1317CB
1R239/ 284	Round bar for arbor 10-100 / 50	Removing Tool retainer from Tool holder for HM1307C, HM1317C
1R291	Retaining ring S and R pliers	Removing / Mounting Retaining ring S-8 from / to Counter shaft
1R306	Ring spring removing jig	Disassembling AVT mechanism
1R346	Center attachment for 1R045	Using with 1R045 to remove Counter shaft
1R347	Tool retainer pole removing tool	Removing Tool retainer pole from Tool retainer

[2] LUBRICATIONS

Apply lubricants to the portions designated with triangles to protect parts and product from unusual abrasion. (Figs. 1 and 2.)

Tool holder section				
Item No.	Description	Portion to lubricate	Lubricant	Amount
⑫	Tool retainer for HM1307C and HM1317C	Drum portion for smooth turning in Bit change	Makita grease R No.00 ▼	a little
⑳	Sleeve 43	Inner wall for smooth action of Impact bolt		
㉑	O ring 45	Whole portion for smooth action of ⑳ Sleeve		
㉒	X ring 36	Whole portion for smooth action of Impact bolt		
㉓	O ring 36	Whole portion for smooth action of Impact bolt		

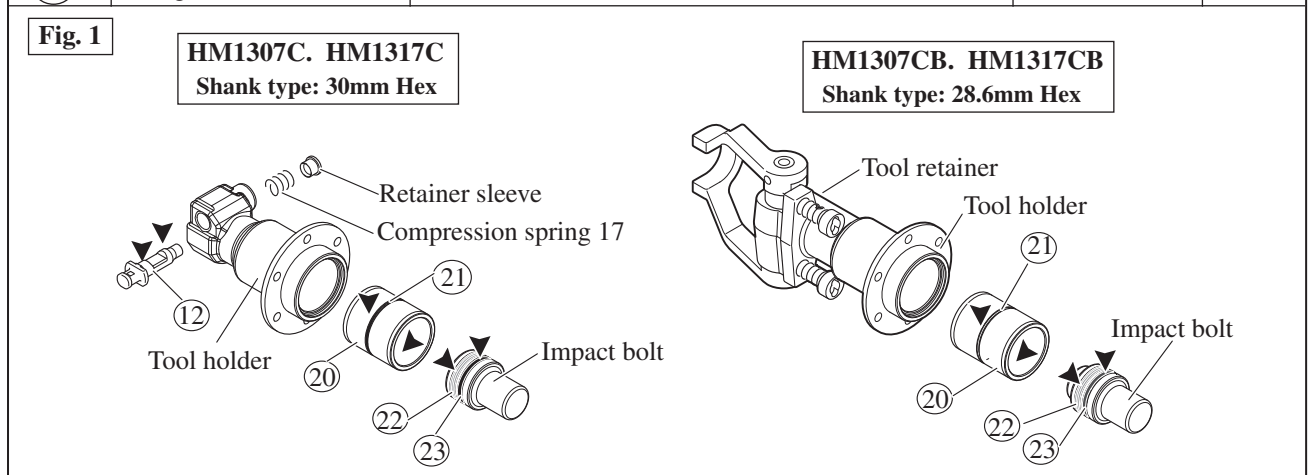

► **Repair**

[2] **LUBRICATIONS (cont.)**

Crank section				
Item No.	Description	Portion to lubricate	Lubricant	Amount
③①	O-ring 42	Whole portion for action of Striker	Makita grease R No.00 ▼	a little
③②	Cylinder 52	③②a Inside between Striker and Shoulder ring 32		10g
		③②b Inside between Striker and Piston		10g
④⑦	O-ring 42	Whole portion for action of Piston		a little
④⑦	O ring 45			
④⑧	Connecting rod		Holes for Pin 12 and Crank shaft	
⑥③	Crank housing complete	⑥③a Gear room for Gear complete 31-43 and Helical gear 47 around Gear cover	Makita grease N.No.1 ▼	60g
		⑥③b Shaft for two Needle cages 1412 and Gear complete 31-43, etc.	Makita grease R No.00 ▼	a little
		⑥③c Crank room	Makita grease R No.00 ▼	70g

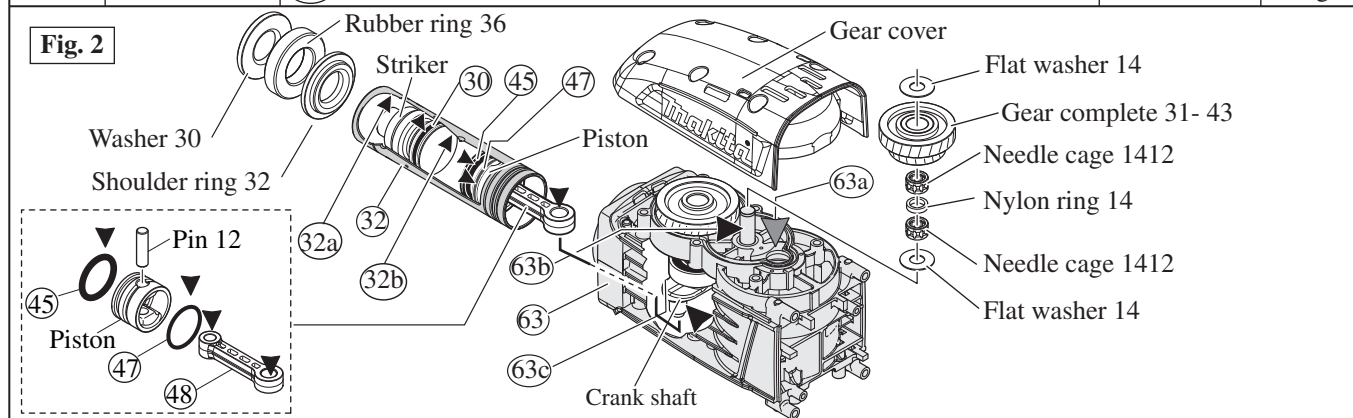

AVT mechanism for HM1317C and HM1317CB				
Item No.	Description	Portion to lubricate	Lubricant	Amount
③⑦	Counter weight	Drum portion for smooth reciprocating in Barrel	Makita grease R No.00	a little
④⑨	Pin 6	Whole portion		
⑥⑦	Needle bearing 1813	Hole portion for smooth rotating of Counter shaft		
⑥⑧	Shoulder washer 8			
⑥⑨	O ring 87	Whole portion		
⑦①	Pin 10	Whole portion		
⑦①	Bearing box complete	Hole portion (Plane bearing 34) for smooth rotating of Counter shaft		
⑦⑧	O ring 74	Whole portion		

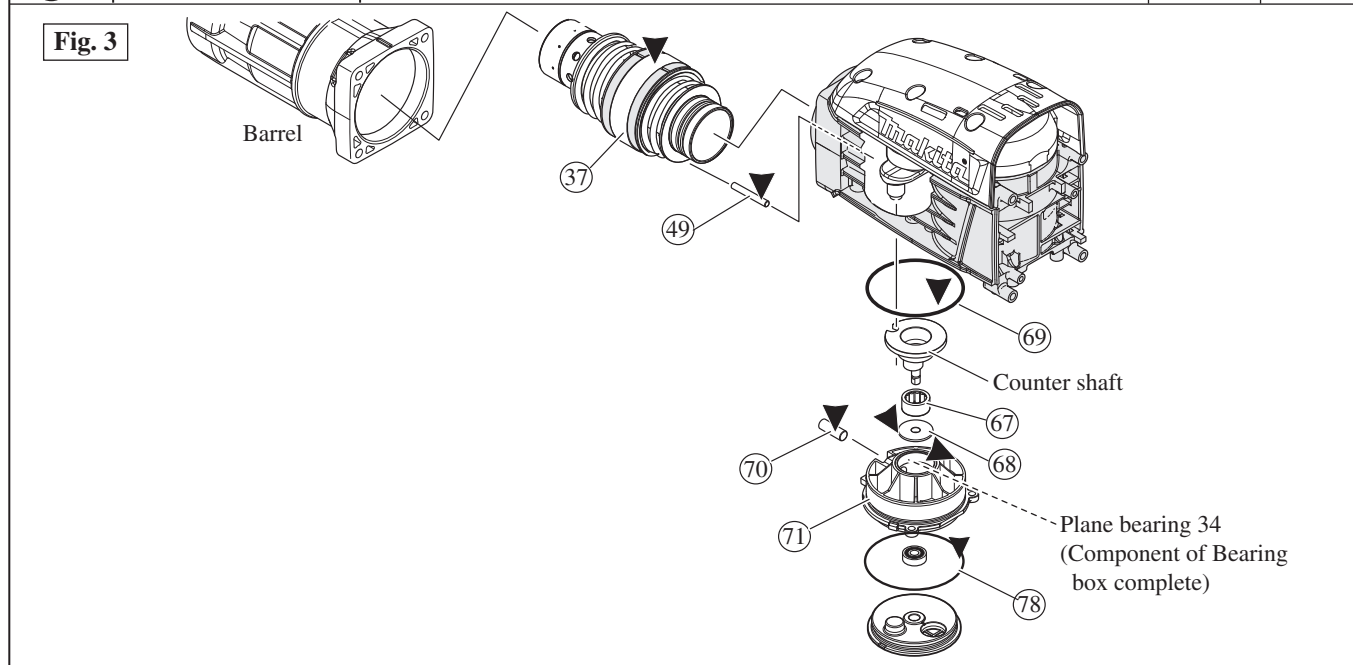

► **Repair**

[3] DISASSEMBLY/ASSEMBLY

[3]-1. Controller, Switch

DISASSEMBLING

Controller Section can be replaced as illustrated in **Fig. 4**.

Fig. 4

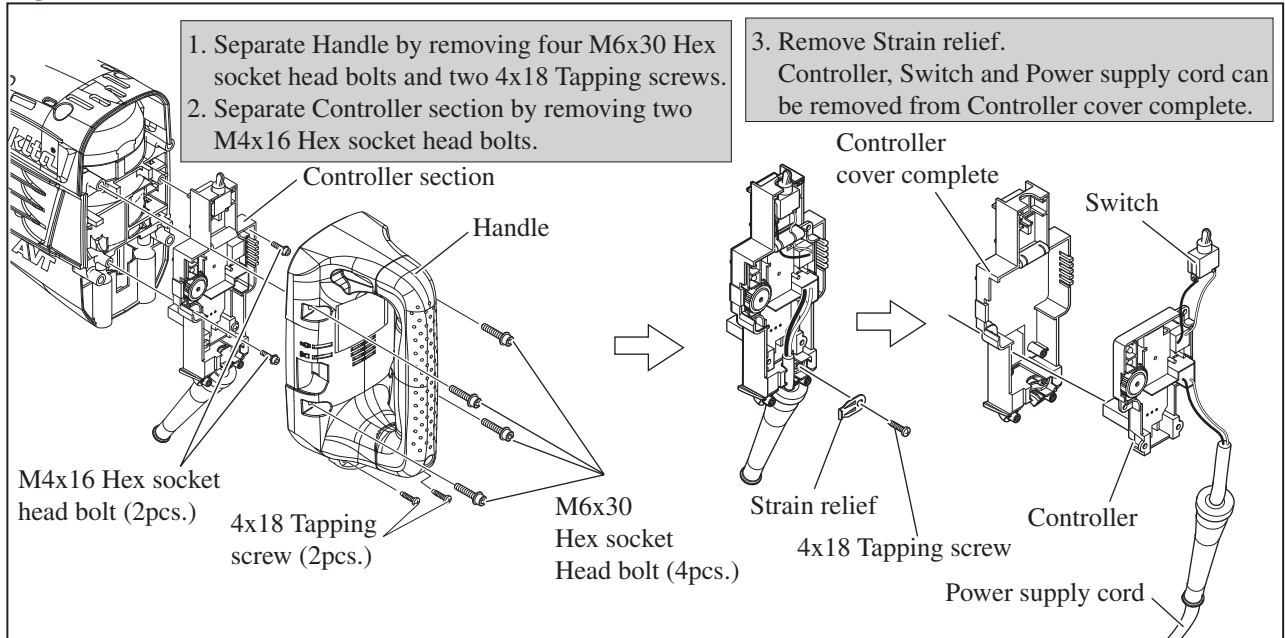

ASSEMBLING

Take the disassembling step in reverse.

Note: Do not forget to mount Pin 4 when replacing switch. (**Fig. 5**)

Fig. 5

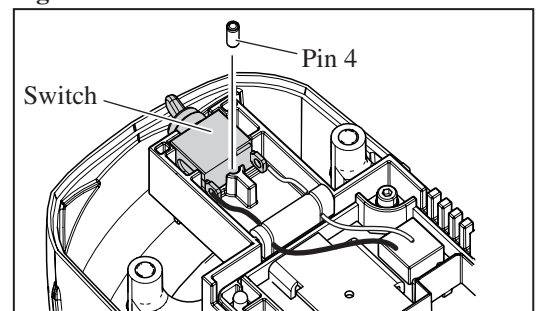

[3]-2. Tool holder section (HM1307C, HM1317C)

DISASSEMBLING

(1) Tool holder section can be disassembled from Barrel as illustrated in **Fig. 6**

(2) Tool holder section is can be disassembled as illustrated in **Fig. 7**.

Fig. 6

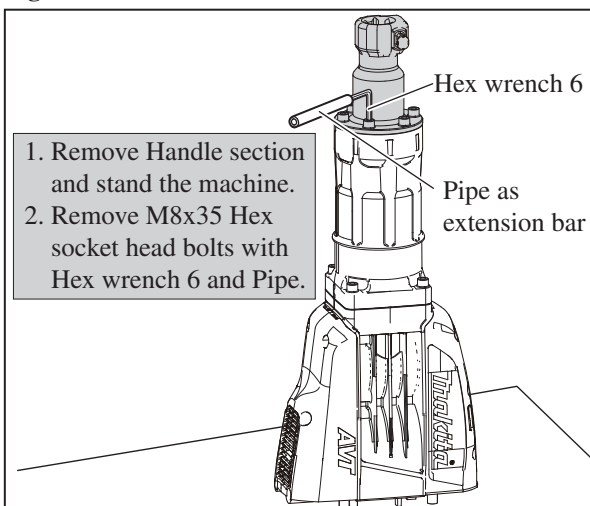
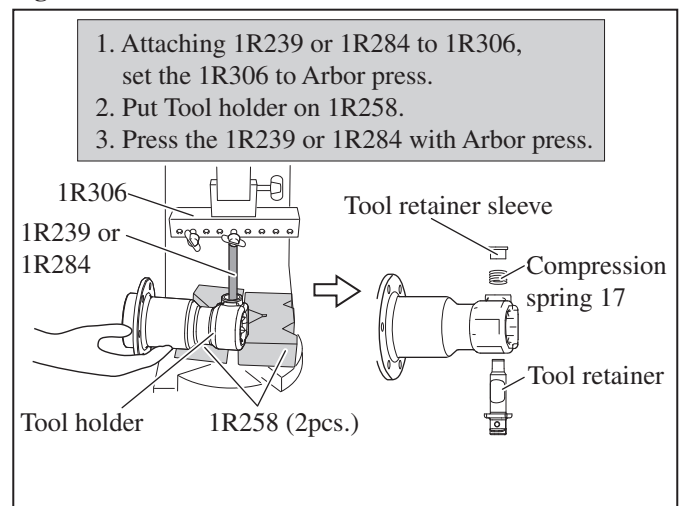

Fig. 7



ASSEMBLING

Take the disassembling step in reverse.

► **Repair**

[3] DISASSEMBLY/ASSEMBLY

[3]-2A. Tool holder section (HM1307CB, HM1317CB)

DISASSEMBLING

Tool retainer of HM1307CB and HM1317CB can be repaired without removing Tool holder from Barrel.
Stand the machine, remove Handle section and stand the machine.

(1) The component parts for Tool retaining mechanism can be disassembled as illustrated in **Figs. 6A and 7A**.

Fig. 6A

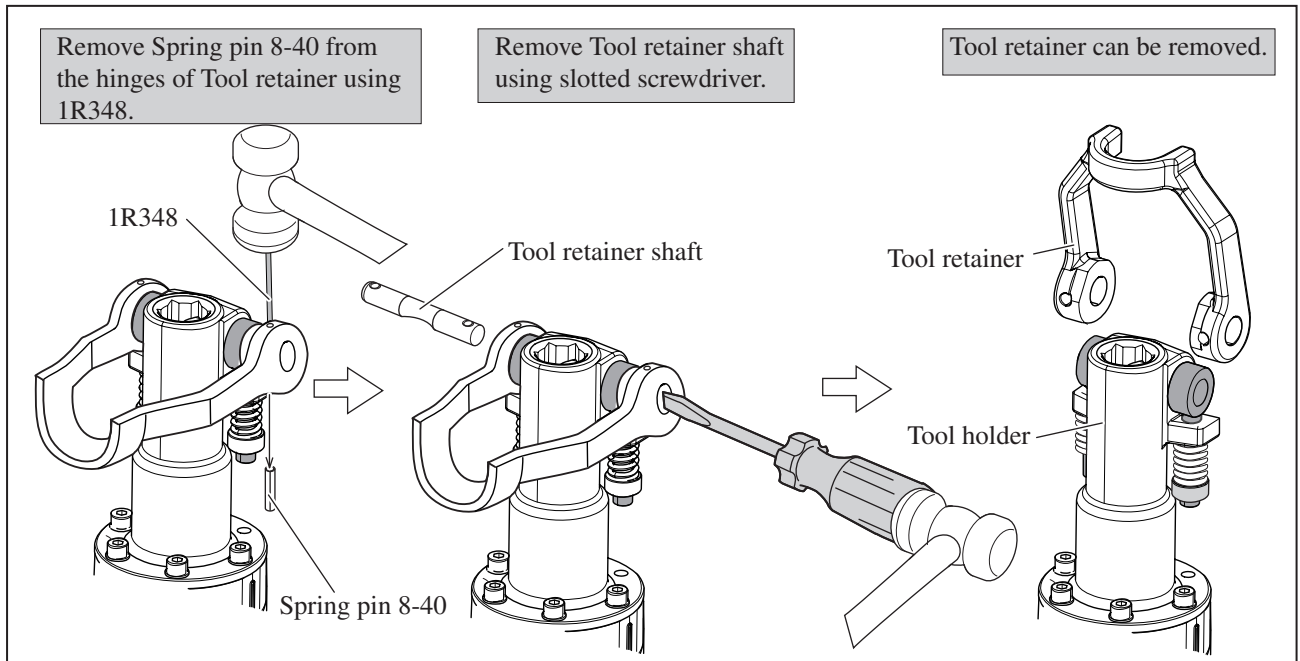
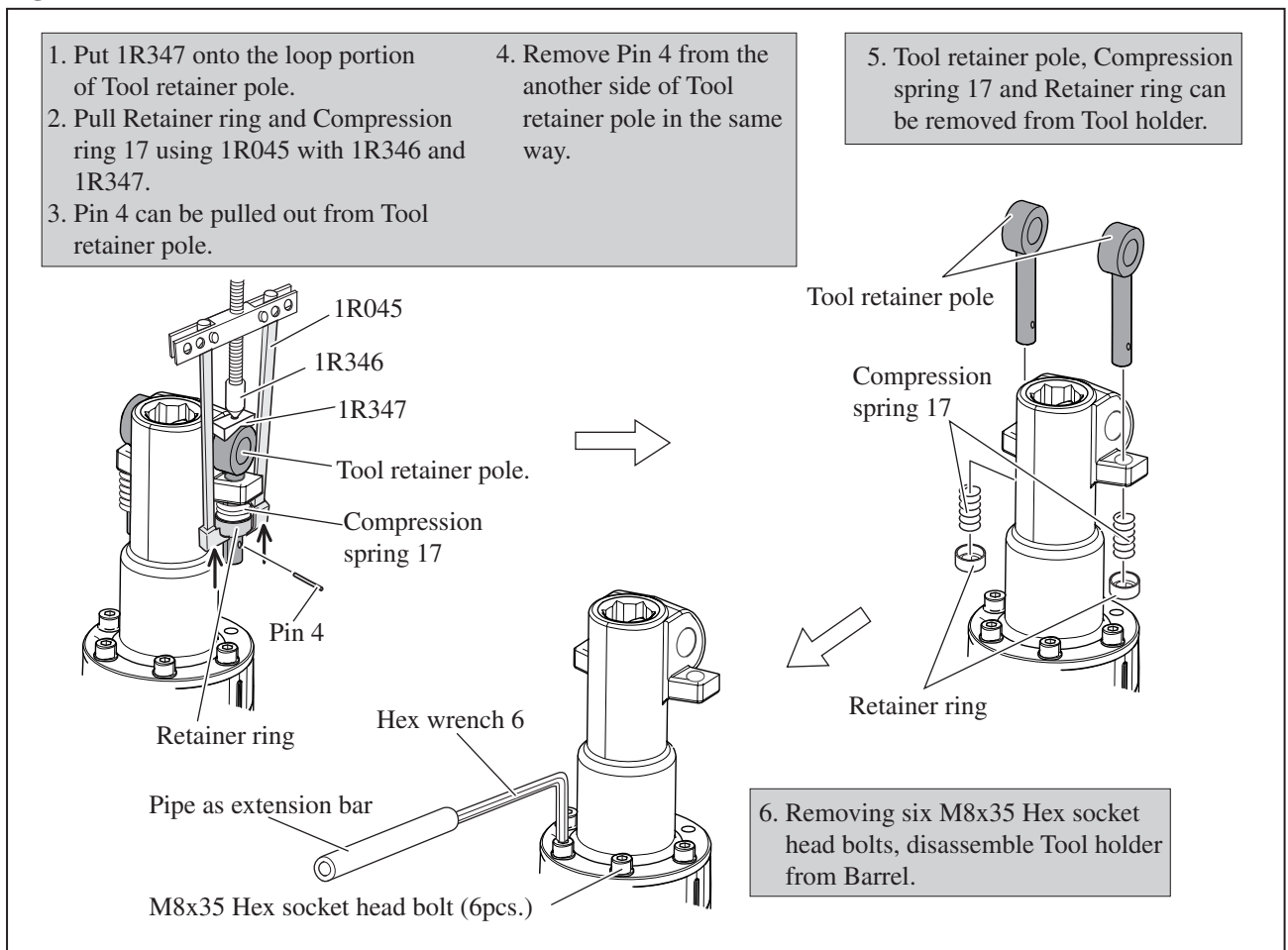

Fig. 7A



► **Repair**

[3] DISASSEMBLY/ASSEMBLY

[3]-2A. Tool holder section (HM1307CB, HM1317CB) (cont.)

ASSEMBLING

- (1) Assemble Tool retainer pole, Compression spring 17, Retainer ring and Pin 4 using 1R347, 1R045 and 1R346. (Fig. 7A)
- (2) While paying attention to directions of the parts shown in Fig. 8, assemble Tool retainer and Tool retainer shaft. (Fig. 9)

Fig. 8

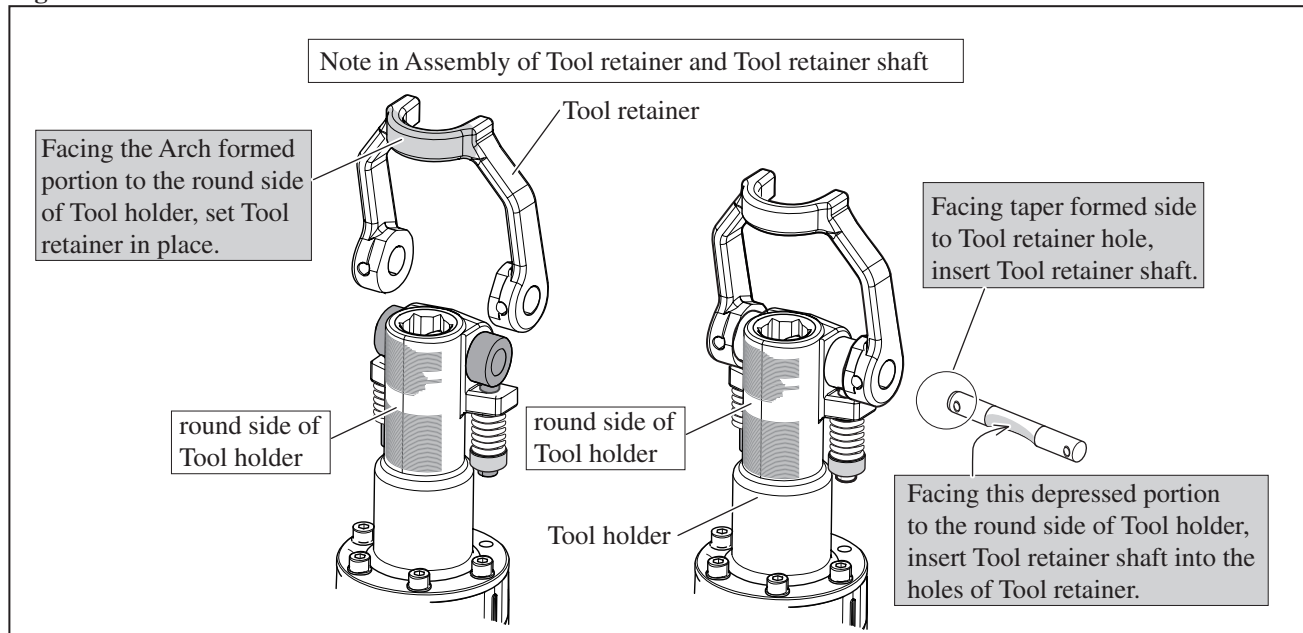
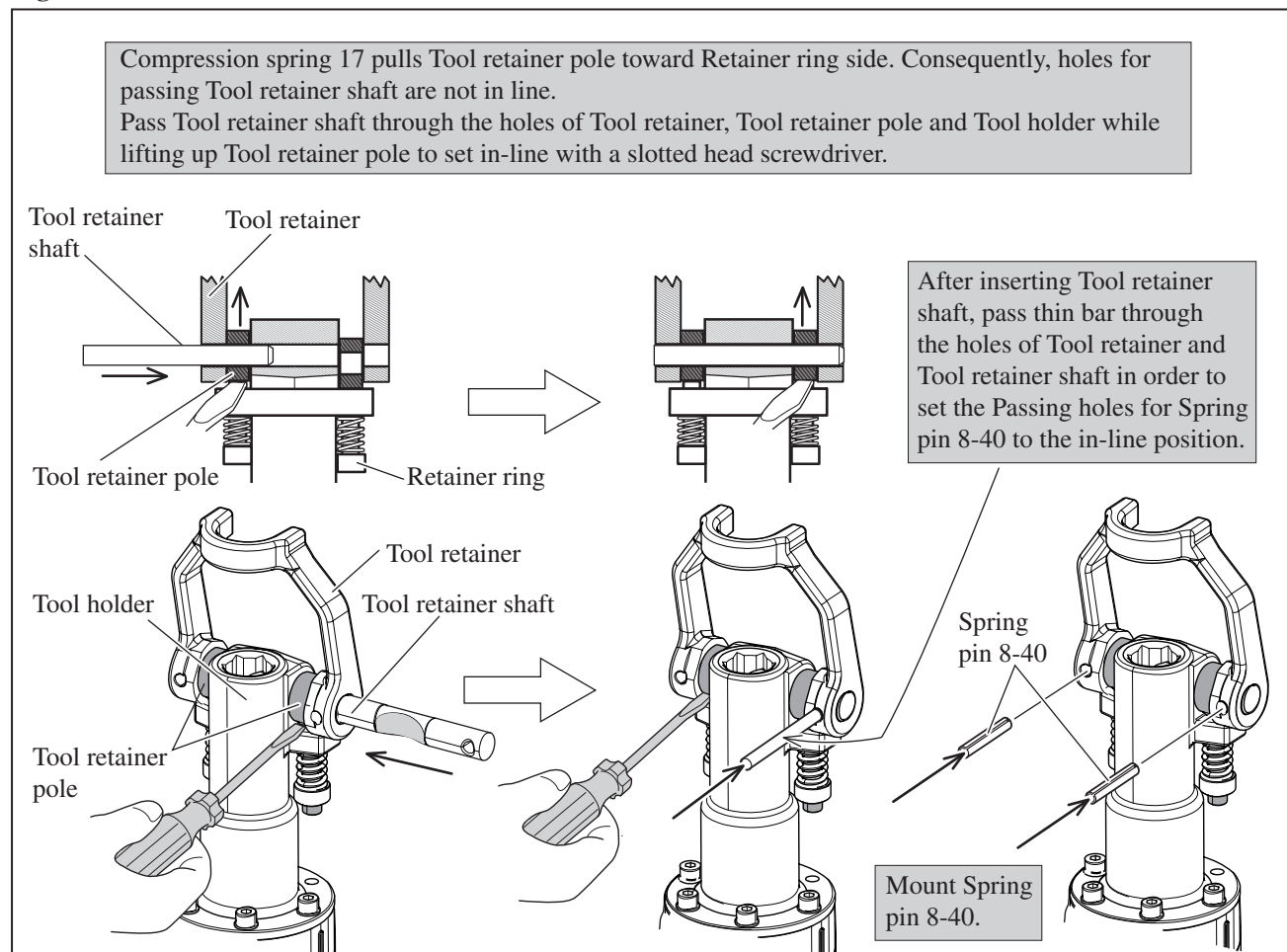

Fig. 9



► **Repair**

[3] DISASSEMBLY/ASSEMBLY

[3]-3. Inside of Tool holder section, Impact bolt

DISASSEMBLING

- (1) Disassemble Handle section as illustrated in **Fig. 4** and stand the machine as illustrated in **Fig.5**.
- (2) Remove six M8x35 Hex socket head bolts with Hex wrench 6 and disassemble Tool holder section as illustrated in **Figs. 10 and 11**.

Fig. 10

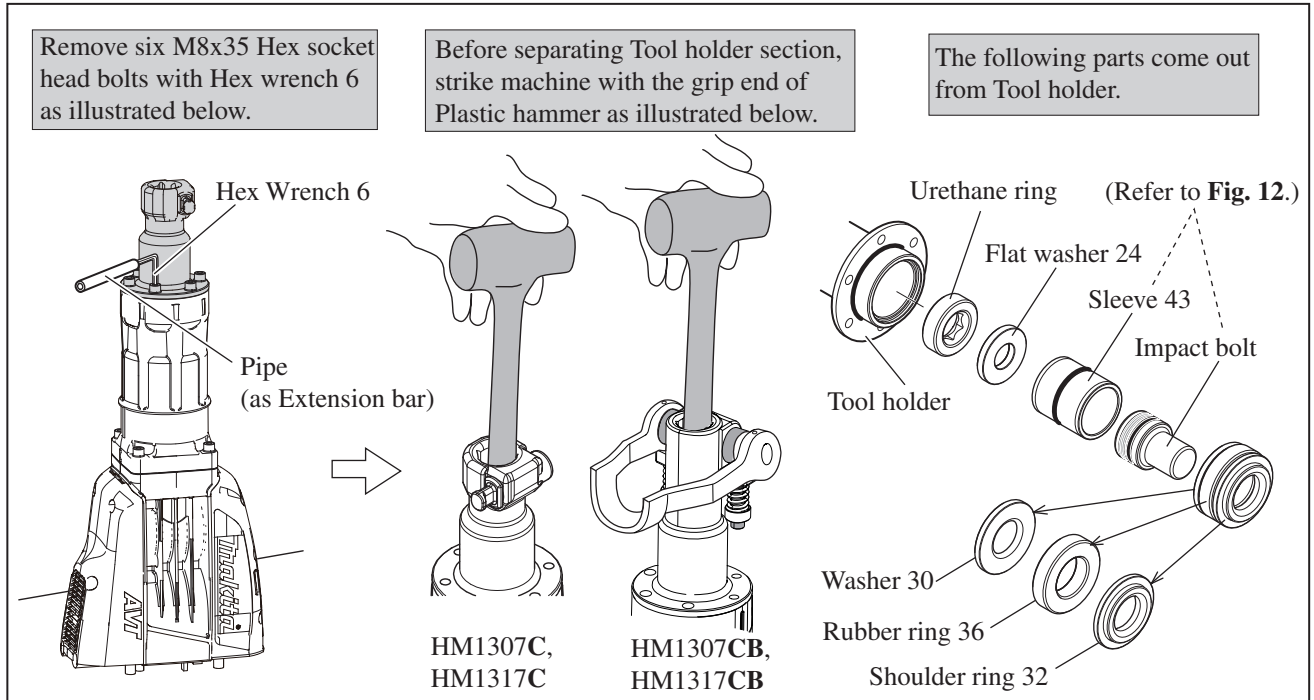
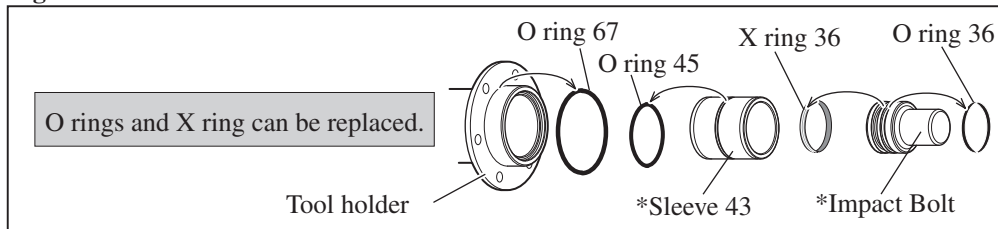

Fig. 11



ASSEMBLING

Take the disassembling step in reverse. Pay attention to the directions and difference shown in **Fig. 12**.

Fig. 12

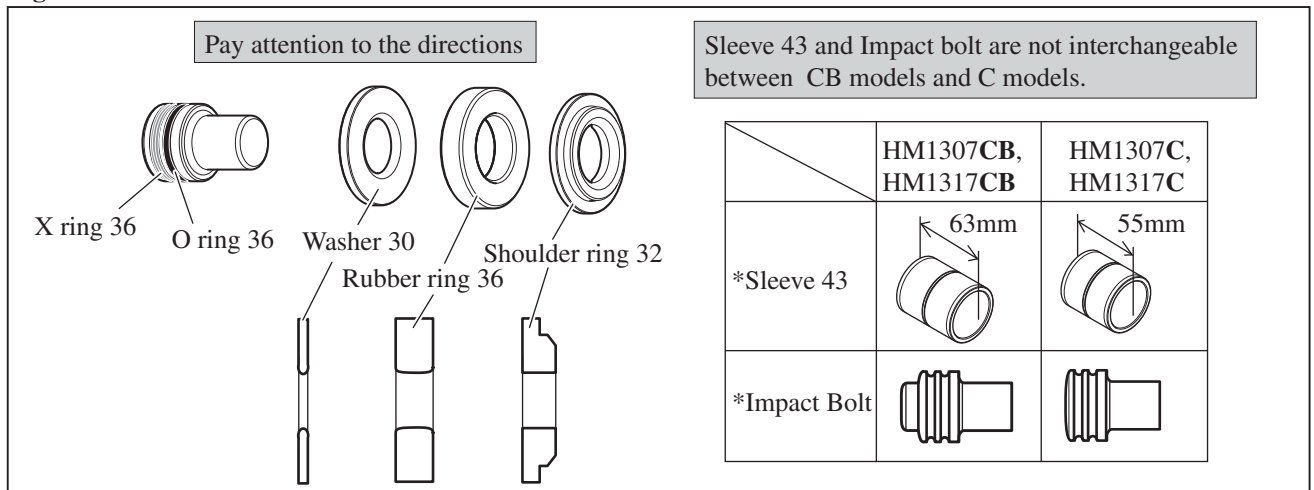

► Repair

[3] DISASSEMBLY/ASSEMBLY

[3]-4. AVT Mechanism of HM1317C and HM1317CB

DISASSEMBLING

- (1) Disassemble Handle section as illustrated in **Fig. 4** and stand the machine as illustrated in **Fig. 5**.
- (2) Disassemble Cylinder 52 from Crank housing. (**Figs. 13 and 14**)

Fig. 13

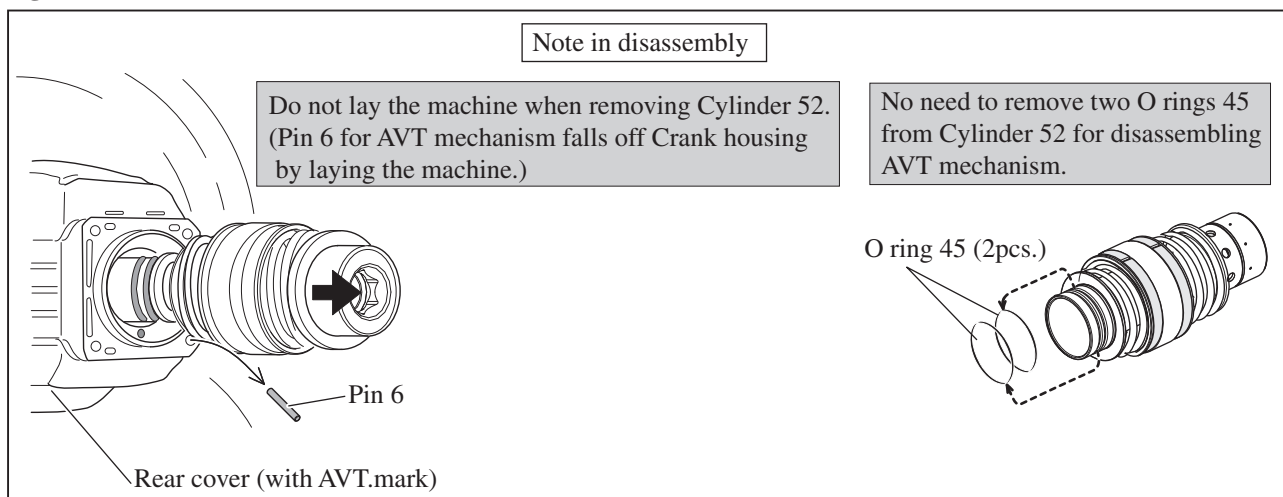
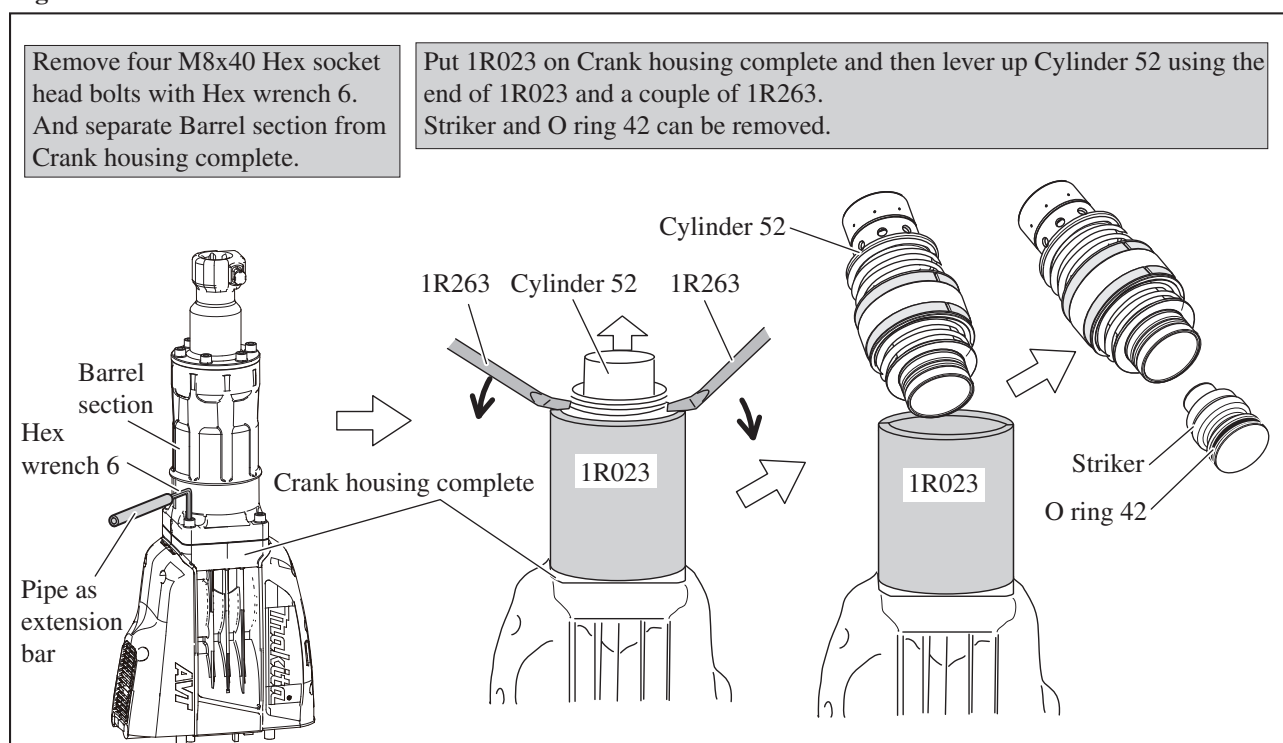

Fig. 14



Also in case of HM1307C, HM1307CB (without AVT. mechanism), Cylinder section can be removed using 1R023 and 1R263 as illustrated in **Fig. 14**.

▶ Repair

[3] DISASSEMBLY/ASSEMBLY

[3]-4. AVT Mechanism of HM1317C, HM1317CB (cont.)

DISASSEMBLING

(3) Disassemble Ring spring 55 which secures the component parts for AVT mechanism as illustrated in **Fig. 15**.

Fig. 15

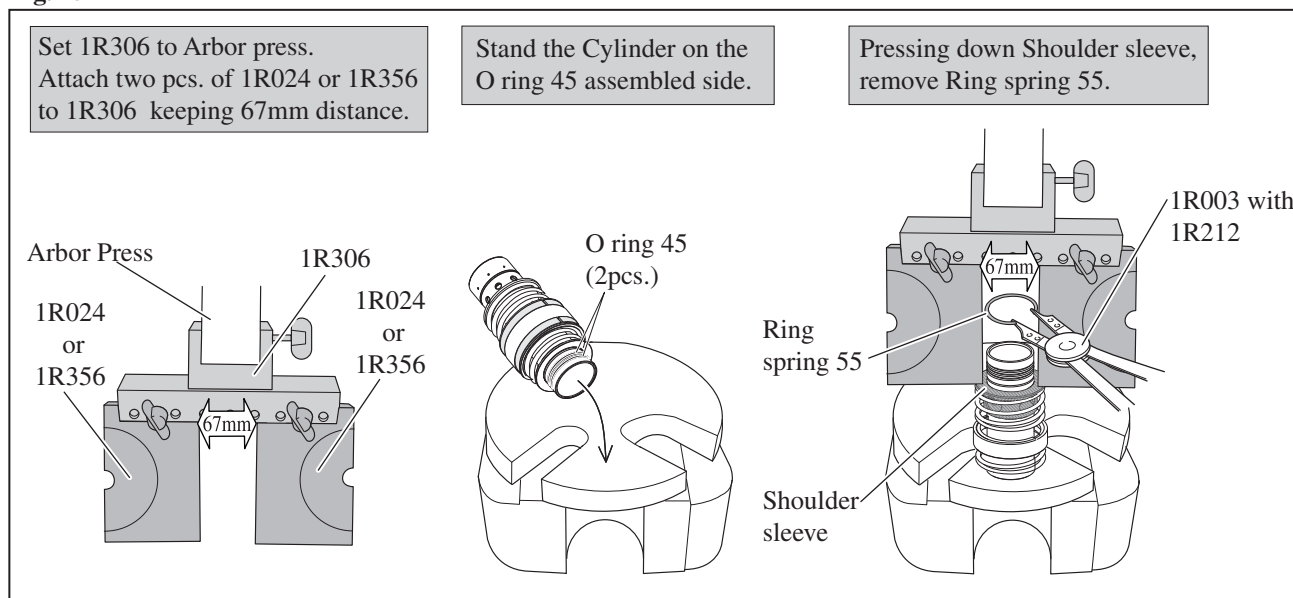
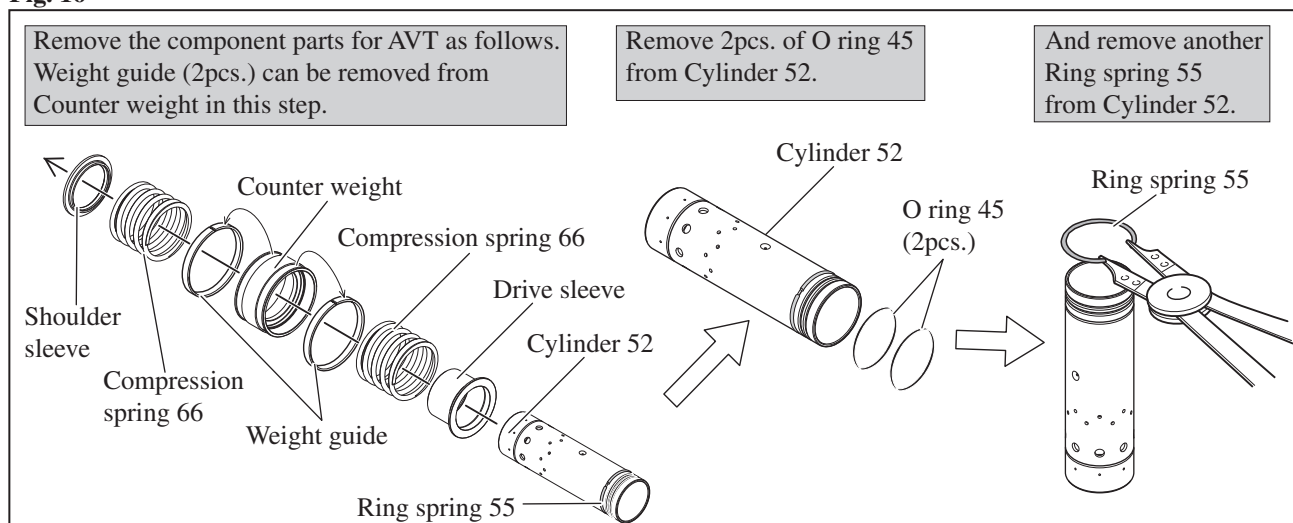

Fig. 16



ASSEMBLING

- (1) Assemble ring spring 15 and 2 pcs. of O ring 45 to Cylinder 52. And then, assemble the component parts for AVT mechanism. Refer to **Figs. 16 and 15**.
- (2) Insert Pin 6 into the position illustrated in **Fig. 17**.

Fig.17

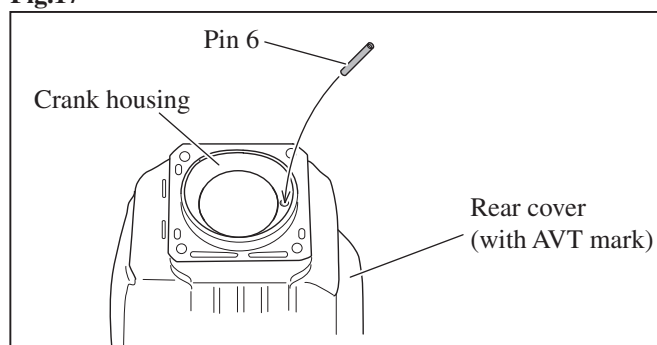

► **Repair**

[3] DISASSEMBLY/ASSEMBLY

[3]-4. AVT Mechanism of HM1317C, HM1317CB (cont.)

ASSEMBLING

(3) Assemble the Cylinder section to Crank housing by striking with plastic hammer.

Pay attention to the position of Distinction mark and assemble Barrel to Crank housing as illustrated in **Fig. 18**.

Fig. 18

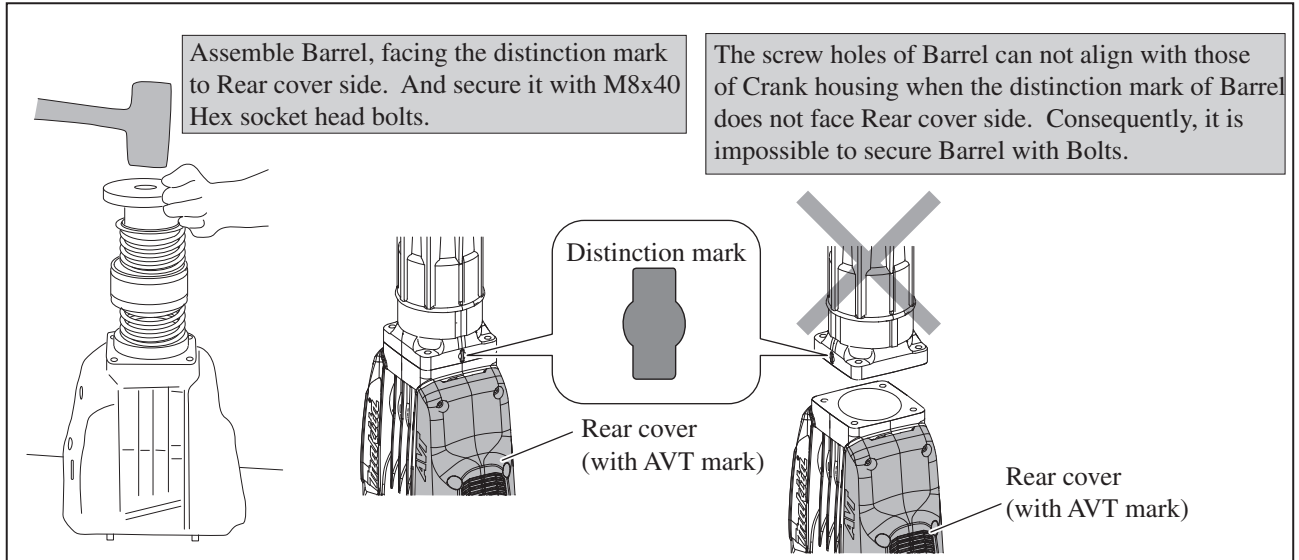

[3]-5. Crank section, Gears

DISASSEMBLING

(1) Separate Handle section and remove Controller and electrical parts as the right illustration in **Fig. 4**.

(2) Disassemble Tool holder section, Barrel and Cylinder section as illustrated in **Fig. 14**.

(3) Disassemble Gear complete section as illustrated in **Fig. 19**.

Fig. 19

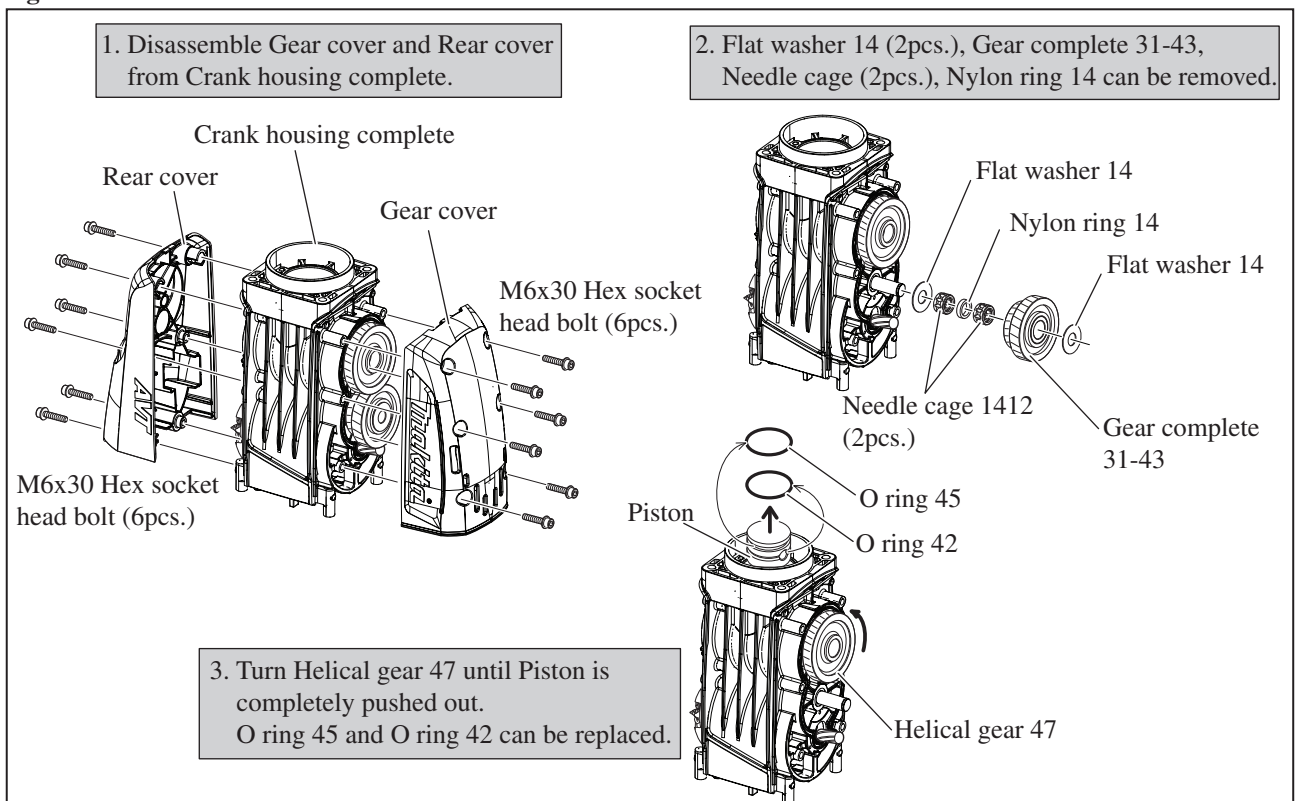

► **Repair**

[3] DISASSEMBLY/ASSEMBLY

[3]-5. Crank section, Gears (cont.)

DISASSEMBLING

(4) Disassemble Armature as illustrated in **Fig. 20**.

Fig. 20

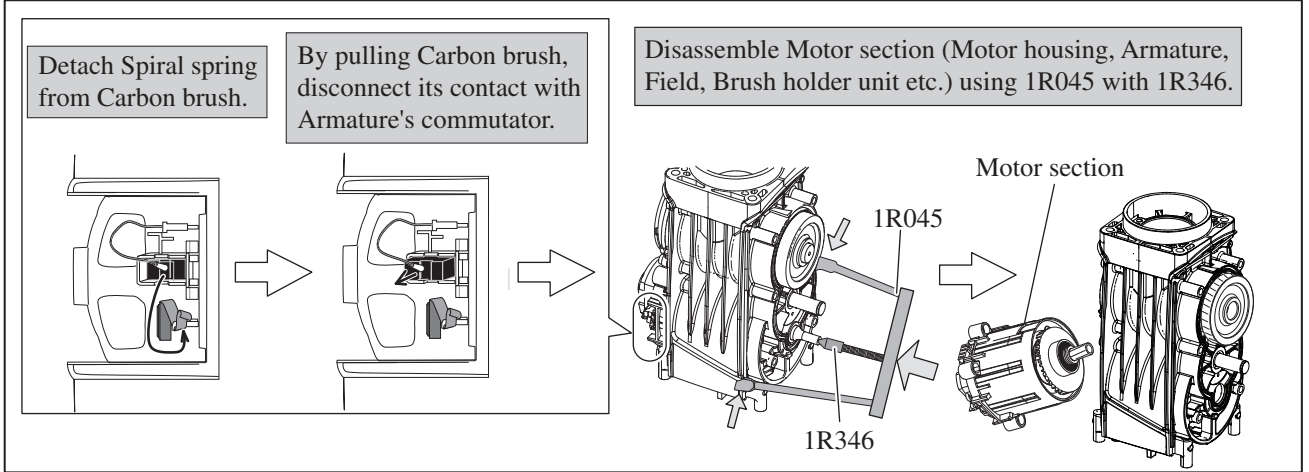

(HM1307C, HM1307CB without AVT mechanism)

DISASSEMBLING

(5A) Disassemble Crank section as illustrated in **Figs. 21A and 22A**.

Fig. 21A

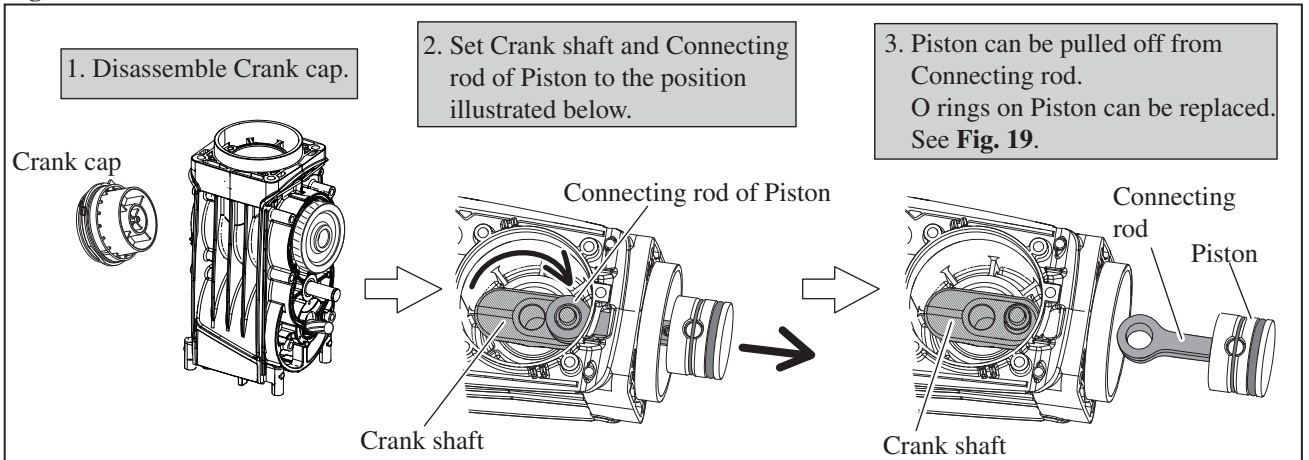
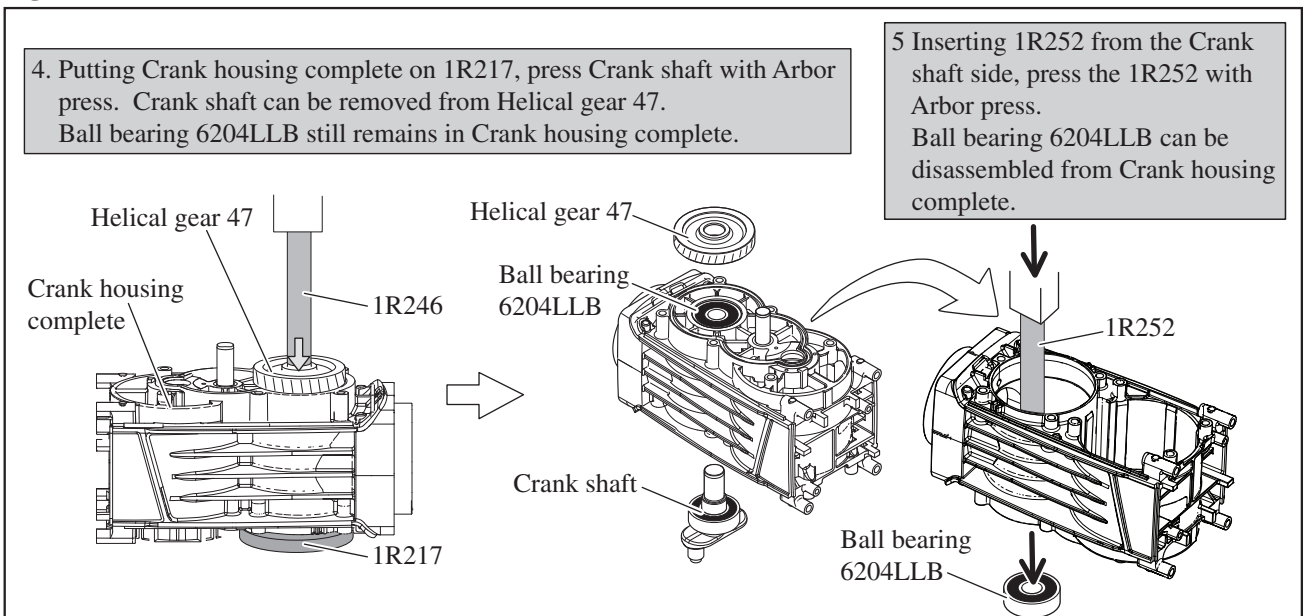

Fig. 22A



► **Repair**

[3] DISASSEMBLY/ASSEMBLY

[3]-5. Crank section, Gears (HM1307C, HM1307CB without AVT mechanism)

DISASSEMBLING

(6A) O rings on Crank cap and Crank cap cover, and Filter can be replaced. See **Fig. 23A**.

Fig. 23A

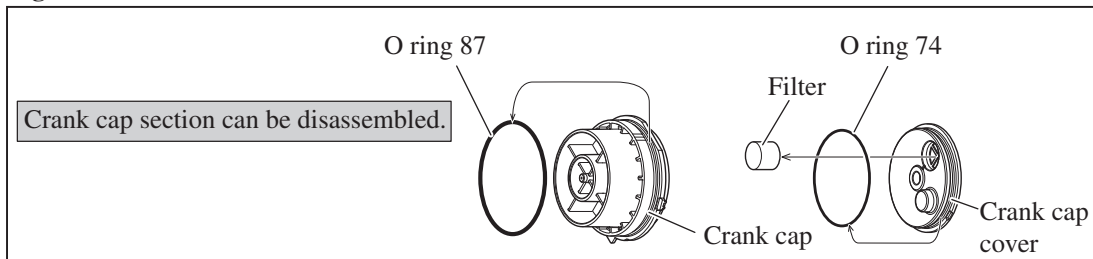

[3]-5A. Crank section, Gears (HM1317C, HM1317CB with AVT mechanism)

DISASSEMBLING

(5B) Disassemble Crank section as illustrated in **Figs. 21B and 22B**.

Fig. 21B

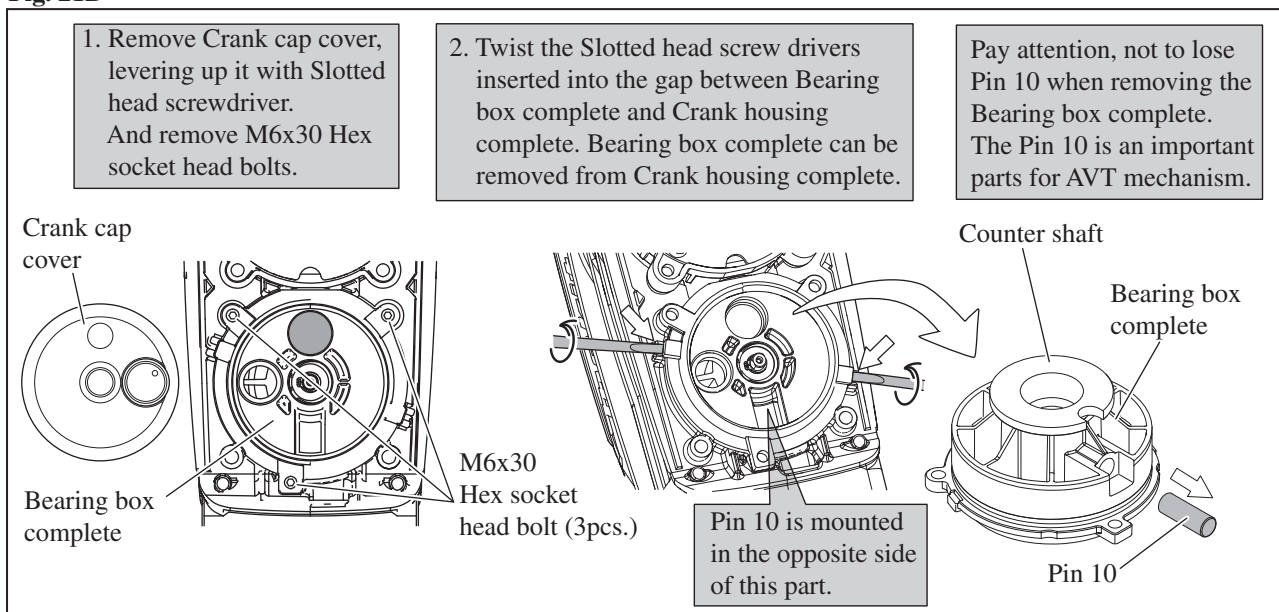
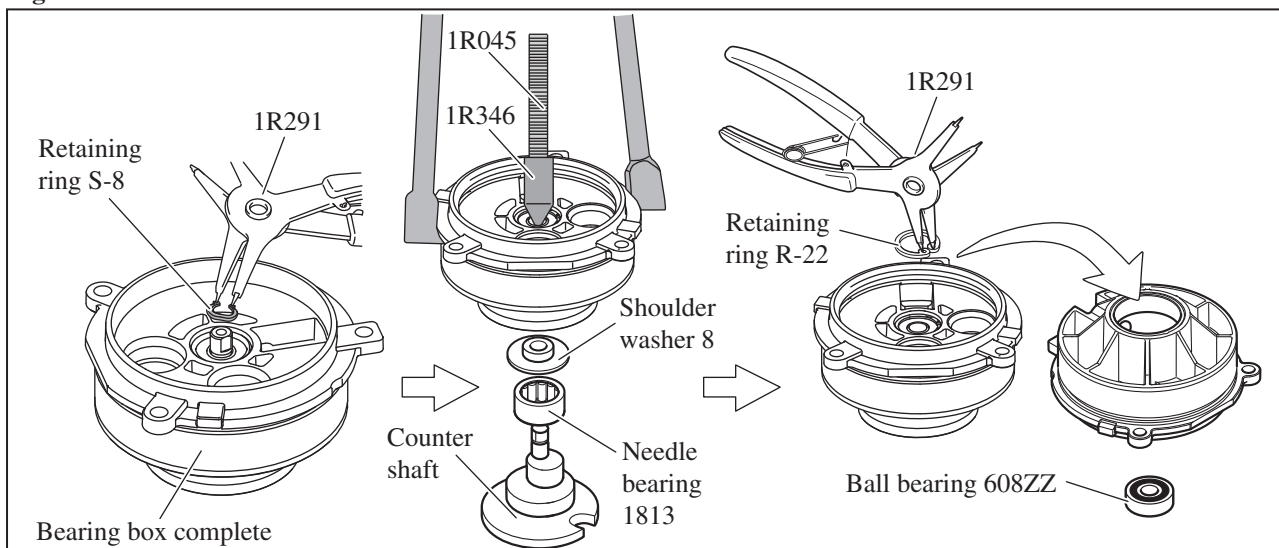

Fig. 22B



► **Repair**

[3] DISASSEMBLY/ASSEMBLY

[3]-5. Crank section, Gears (HM1317C, HM1317CB with AVT mechanism)

DISASSEMBLING

(6B) After removing Bearing box complete as illustrated in Fig. 20B, Crank shaft comes into your sight.
Remove Piston as illustrated in **Fig. 23B**.

Fig. 23B

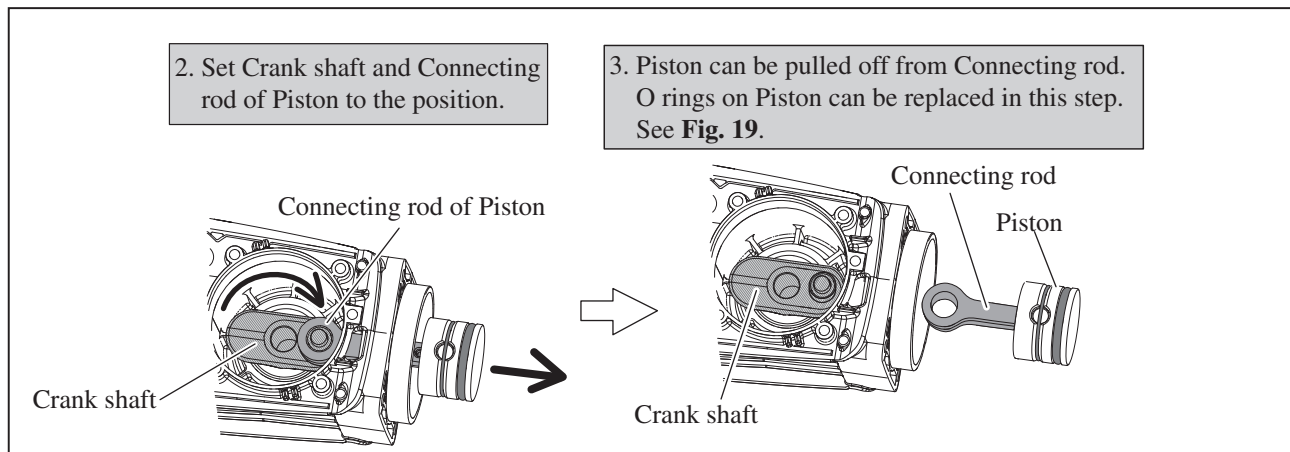

(7B) O rings on Bearing box complete, Crank cap cover, and Filter can be replaced. See **Fig. 24B**.

Fig. 24B

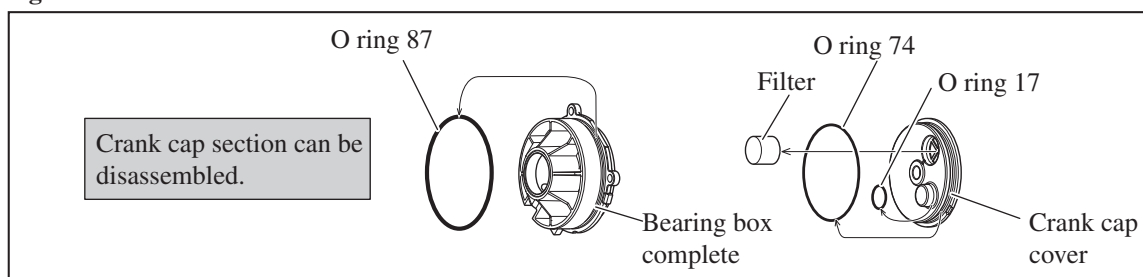

(8B) Crank shaft and Helical gear 47 can be disassembled as illustrated in **Fig. 25B**.

Fig. 25B

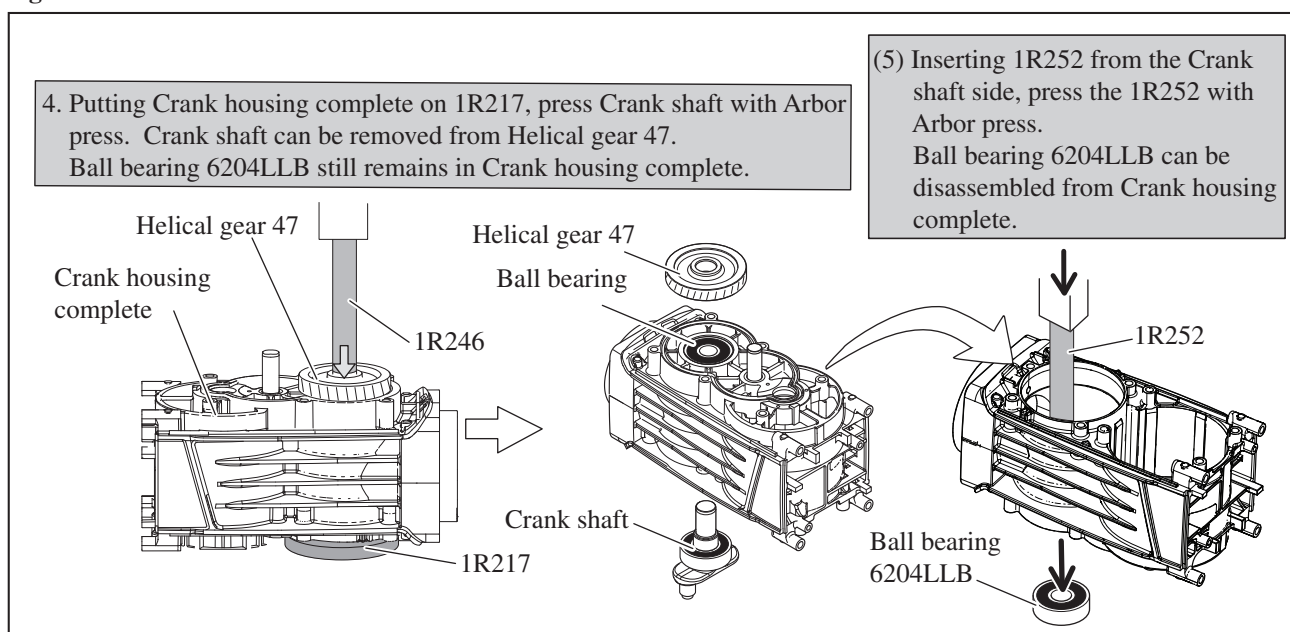

► **Repair**

[3] DISASSEMBLY/ASSEMBLY

[3]-5. Crank section, Gears

ASSEMBLING

(1) Assemble Crank shaft as illustrated in **Fig. 26**.

Fig. 26

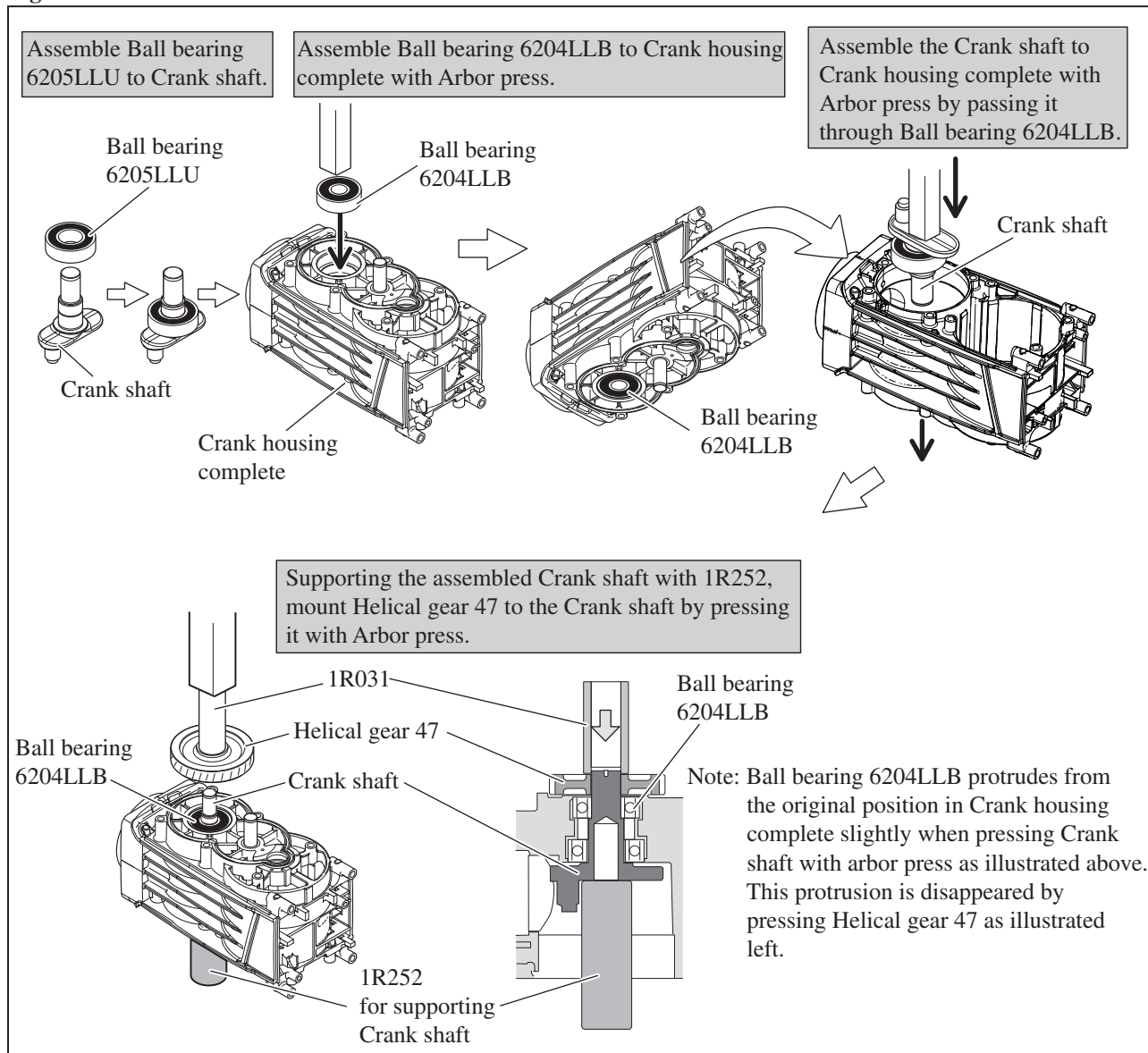

(HM1307C, HM1307CB without AVT mechanism)

(2A) Assemble Piston to Crank shaft. and assemble Crank cap section. Refer to **Fig. 21A**.

(HM1317C, HM1317CB with AVT mechanism)

(2B) Assemble Bearing box complete by taking the disassembling step in reverse. Refer to **Figs. 24B,23B, 22B and 21B**. When mounting Bearing box complete to Crank housing, pay attention to **Fig. 27**.

Fig. 27

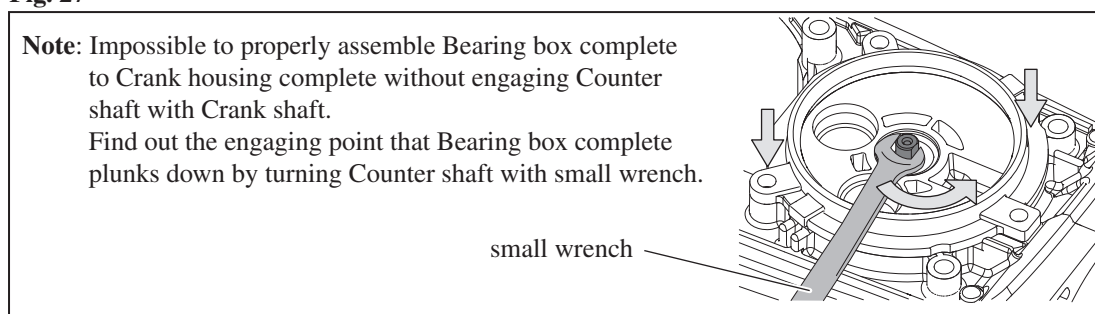

► Repair

[3] DISASSEMBLY/ASSEMBLY

[3]-5. Crank section, Gears

ASSEMBLING

(3) Assemble Gear complete section and Motor section as illustrated in **Fig. 28**.

Note: Do not forget to set two Flat washers 14 in place.

Fig. 28

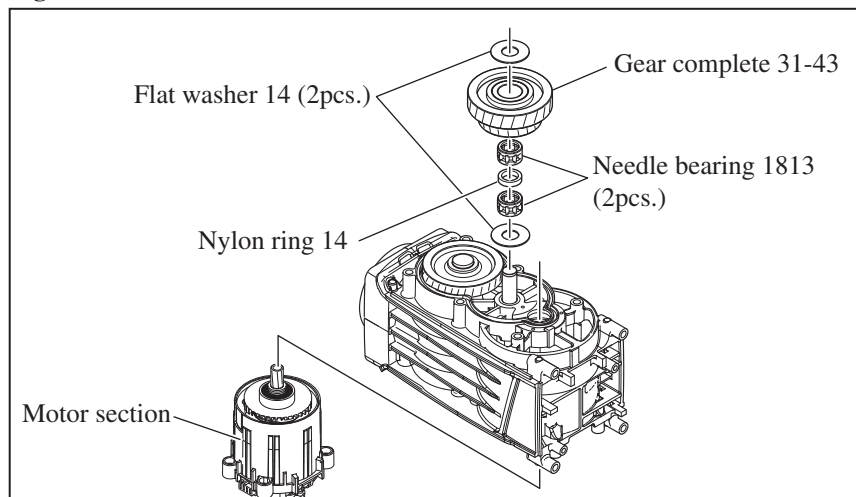

[3]-6. Motor section

DISASSEMBLING

(1) Separate Handle section and remove Controller and electrical parts as **the right illustration in Fig. 4**.

(2) Separate Barrel section and Cylinder section as illustrated in **Fig. 14**.

(3) Disassemble Gear cover and Rear cover as illustrated in **Fig. 19**.

(4) Separate Motor section from Crank housing complete as illustrated in **Fig. 20**.

(5) Disassemble Motor section as illustrated in **Fig. 29**.

Fig. 29

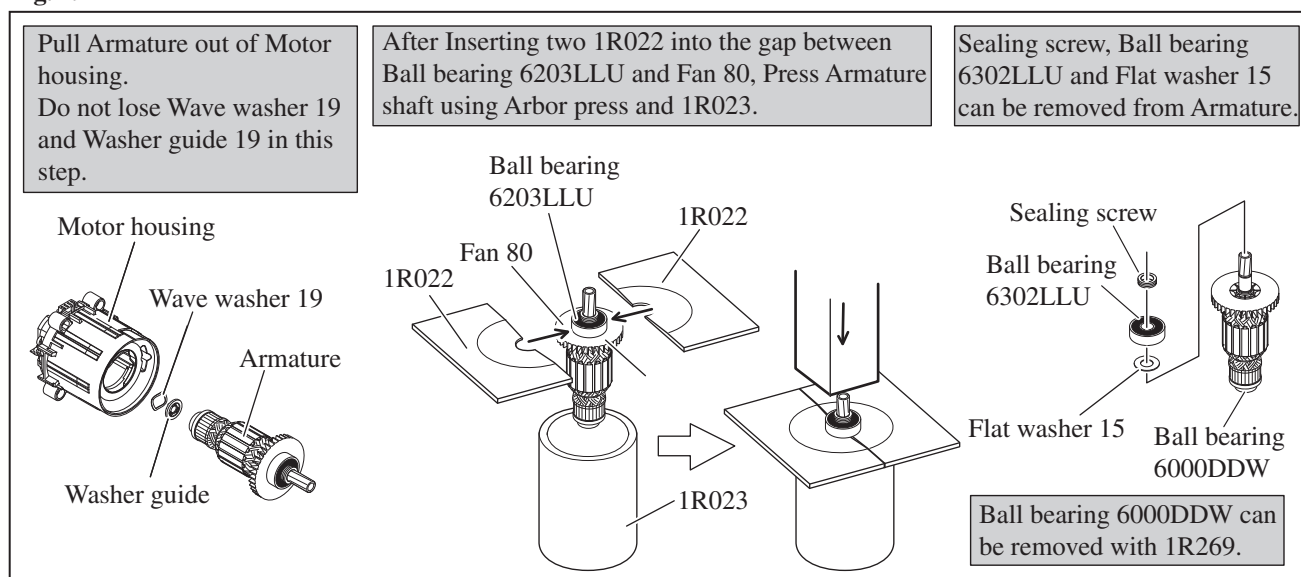

ASSEMBLING

Taking the disassembling step in reverse.

Note: Do not forget to mount the following small parts.

- * Flat washer 15: between Ball bearing 6203LLU and Fan 80 Refer to the **right illustration in Fig. 29**.
- * Wave washer 19 and Washer guide: Motor housing Refer to the **left illustration in Fig. 29**.

► Repair

[3] DISASSEMBLY/ASSEMBLY

[3]-7. Switch lever, Slide lever in Handle

DISASSEMBLING

- (1) Separate handle section from the machine as per the **left** illustration in **Fig. 4**. Controller, Switch and Power supply cord can be replaced in this step.
- (2) Switch lever and Slide lever can be removed as illustrated in **Fig. 30**.

Fig. 30

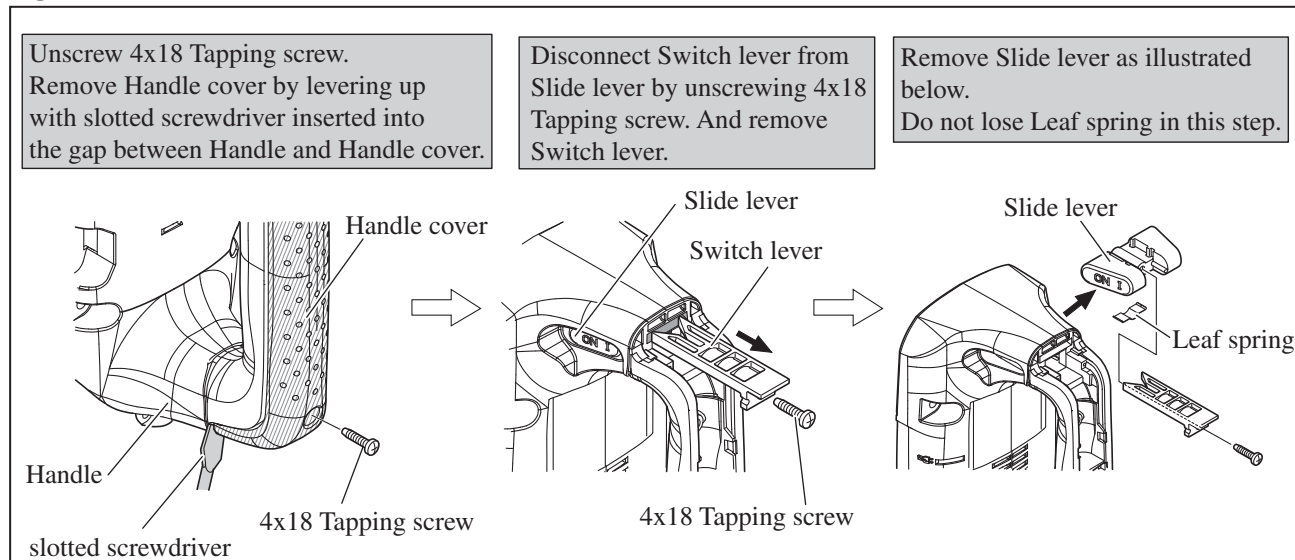

ASSEMBLING

- (1) Assemble Slide lever and Switch lever to Handle section. Refer to **Fig. 30**.
- (2) Assemble Handle to the machine as illustrated in **Fig. 31**.
- (3) Assemble Handle cover to Handle. Refer to **Fig. 30**.

Fig. 31

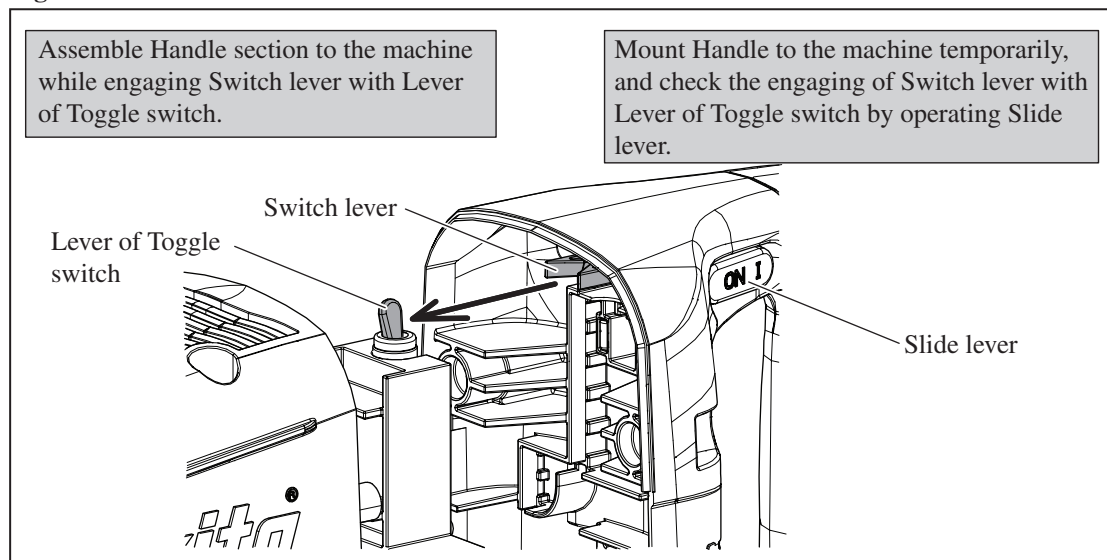

► **Repair**

[3] DISASSEMBLY/ASSEMBLY

[3]-10. Fastening torque

Fasten Hex socket head bolts to the fastening torque listed in **Fig. A**.

Fig. A

Item No.	Size	Q'ty	Fastening torque	Use for
⑭	M8 x 35	4	30 - 40 N.m	Fastening Tool holder to Barrel
③⑤	M8 x 40	4	30 - 40 N.m	Fastening Barrel to Crank housing complete
⑤②	M6 x 30	6	13 - 16 N.m	Fastening Gear cover to Crank housing complete
⑦④	M6 x 20	3	13 - 16 N.m	Fastening Bearing box to Crank housing complete
⑧②	M6 x 30	6	4 - 6 N.m	Fastening Rear cover to Crank housing complete
⑩⑧	M4 x 16	1	1 - 2 N.m	Fastening Controller to Crank housing complete
①①⑦	M6 x 30	4	4 - 6 N.m	Fastening Handle to Crank housing complete

Note: Apply ThreeBond 1342 or Loctite 242 to the threads of all Hex socket head bolts.

Bearing box complete and ⑦④ M6x20 Hex socket bolts are assembled to HM1317C and HM1317CB only.

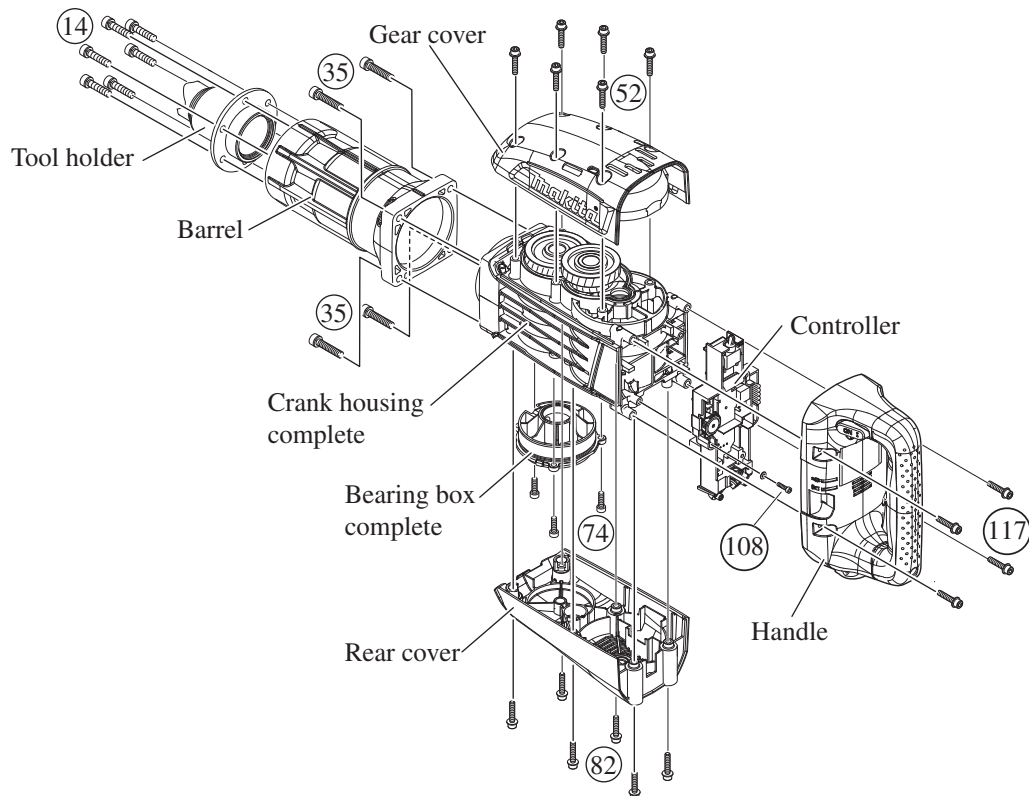

[4] MAINTENANCE PROGRAM

1. When replacing carbon brush, it is recommended to replace the following maintenance at the same time for longer service life of the machine. (**Fig. B**)
2. Wipe off the old grease from Crank housing complete and Gear cover, and then apply the new grease.

Item No.	Description
②②	X ring 36
③①	O ring 42
②③	O ring 36
④⑤	O ring 42
④⑦	O ring 45

Fig. B

▶ Circuit diagram

Fig. D-1

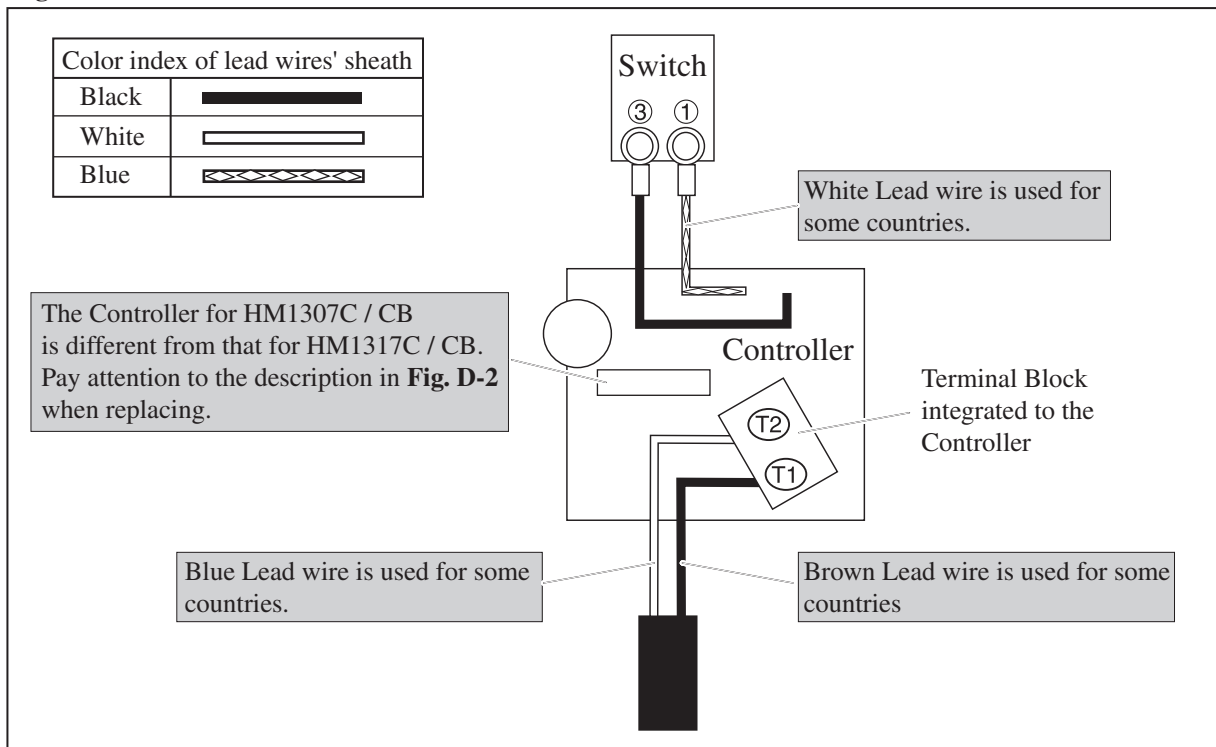

▶ Wiring diagram

Fig. D-2

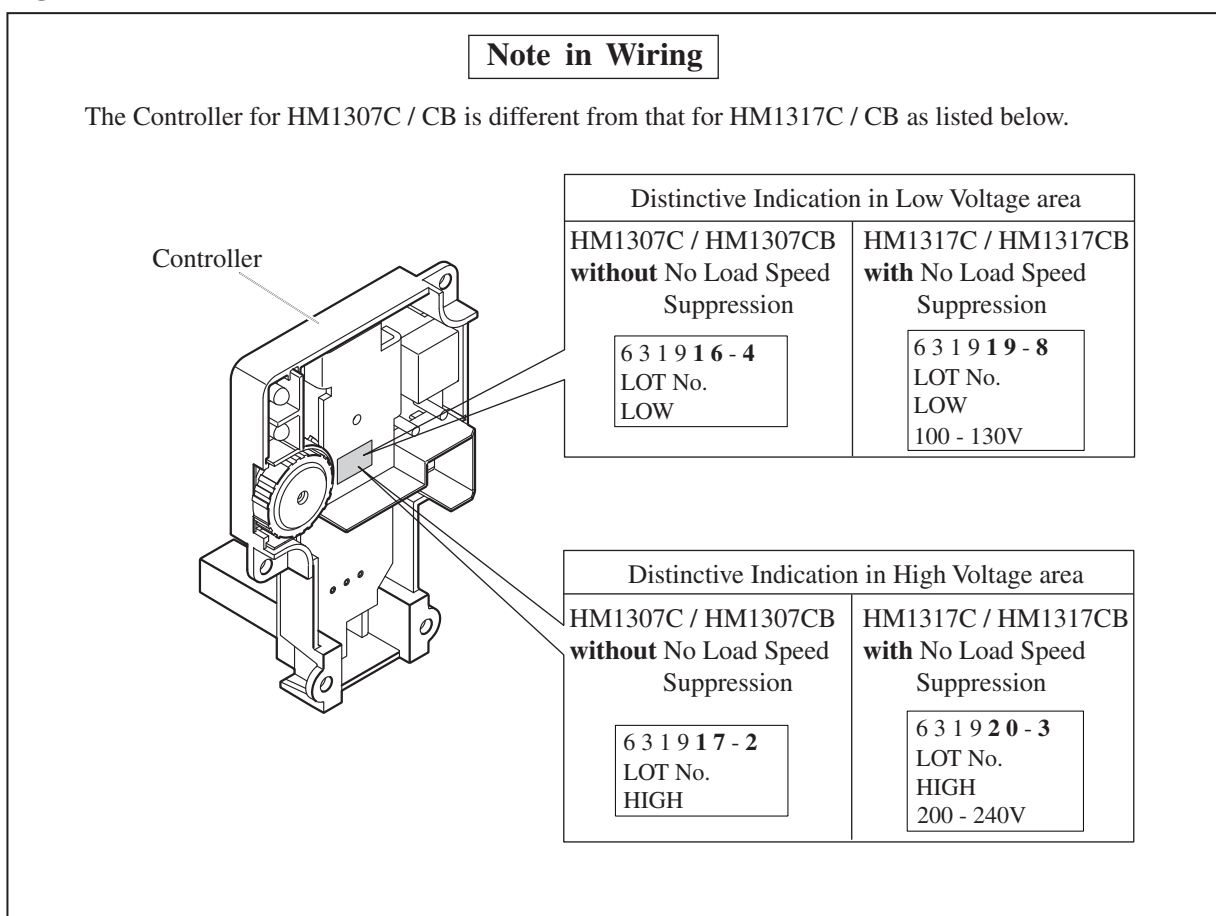

► **Wiring diagram**

Fig. D-3

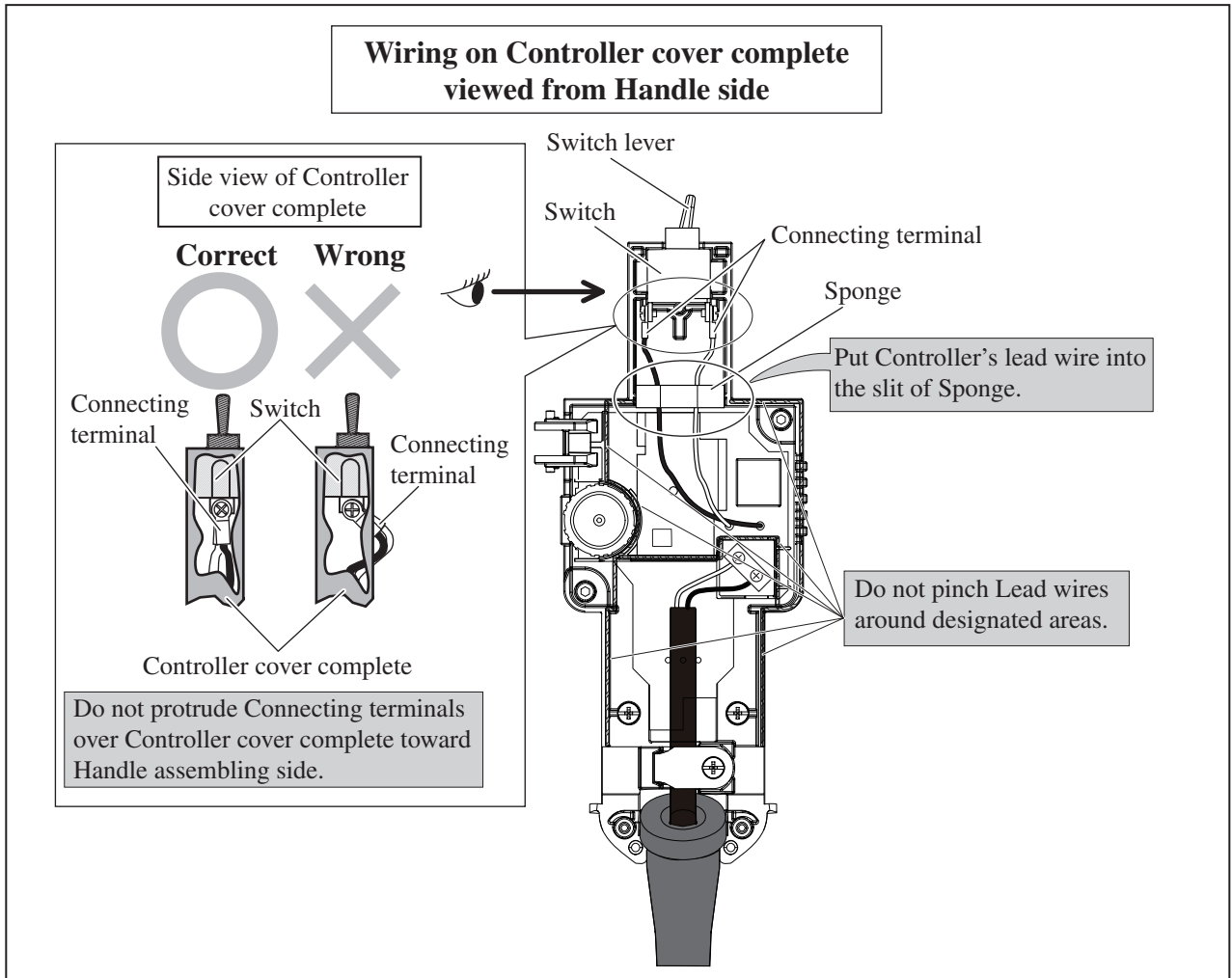

Wiring of Carbon Brush

Insert Carbon brush into Brush holder as the **left illustration** in Fig. D-4.

Fig. D-4

