

TECHNICAL INFORMATION



PRODUCT

P 1 / 6

Model No. ▶ GA7020/ GA7020S, GA7021, GA9020/ GA9020S

Description ▶ Angle Grinders 180mm (7")/ 230mm (9")

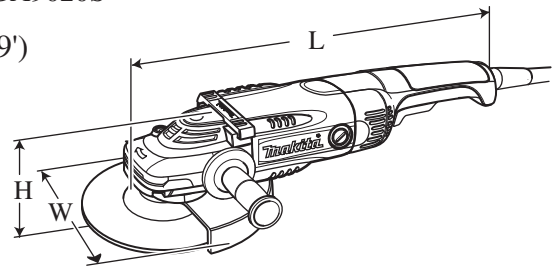

CONCEPT AND MAIN APPLICATIONS

The above products have been developed as the successor models to the current 9067/ 9069 series models, featuring durability higher than the predecessors.

Also the following optional accessories will provide more comfort and control;

- *Vibration absorbing side grip for comfortable work
- *Toolless wheel cover for quick adjustment
- *Dust cover attachment

GA7020S and GA9020S feature soft start.

GA7021 is designed on GA7020 for low-speed and high-torque.

Dimensions: mm (")		
Model No.	GA7020 GA7020S GA7021	GA9020 GA9020S
Length (L)	473 (18-5/8)	
Width (W)	200 (7-7/8)	249 (9-3/4)
Height (H)	140 (5-1/2)	

► Specification

Voltage (V)	Current (A)	Cycle (Hz)	Continuous Rating (W)		Max. Output (W)
			Input	Output	
110	15	50/ 60	1,650	1,100	2,750
120	15	50/ 60	---	1,100	2,750
220	10.5	50/ 60	2,200	1,400	3,300
230	10.1	50/ 60	2,200	1,400	3,300
240	9.6	50/ 60	2,200	1,400	3,300

Model No.	GA7020	GA7020S	GA7021	GA9020	GA9020S
Wheel size: mm (")	Diameter			230 (9)	
	180 (7)				
	Hole diameter				
	22.23 (7/8)				
No load speed: min ⁻¹ =rpm.	8,500		b) 6,600		
Soft start feature	No	Yes	No	No	Yes
AC/DC switch	c) Yes				
Double insulation	Yes				
Power supply cord: m (ft)	Australia, New Zealand: 2.0 (6.6), Other countries: 2.5 (8.2)				
Net weight: kg (lbs)	4.7 (10.4)				

a) Differs by country.

b) 6,000 for USA, Guam, Panama

c) Exclusively for North American countries

► Standard equipment

Lock nut wrench 35 1 pc

Side grip 36 1 pc

Note: The standard equipment for the tool shown above may differ by country.

► Optional accessories

Vibration absorbing side grip

Toolless quick adjustable wheel cover

Dust cover attachment

GA7020/ GA7020S, GA7021: Assorted accessories for 180mm angle grinder

GA9020/ GA9020S: Assorted accessories for 230mm angle grinder

► Repair

CAUTION: Remove the wheel from the machine for safety before repair/ maintenance !

[1] NECESSARY REPAIRING TOOLS



Code No.	Description	Use for
1R048	Drill chuck remover 11	Removing Spiral bevel gear 53
1R049	Drill chuck remover 15	Removing Spiral bevel gear 53
1R269	Bearing extractor	Removing Ball bearings
1R005	Retaining ring R pliers	Removal/installation of Retaining ring R-42
1R165	Ring spring setting tool B	Assembling Spiral bevel gear 53

[2] LUBRICATION

Put approx. 60g of Makita grease SG No.1 in the gear room of Gear housing complete to protect parts and product from unusual abrasion.

[3] DISASSEMBLY/ASSEMBLY

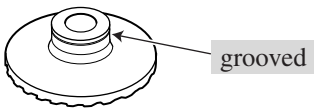
Important: As listed below, different gears are used for GA7020/GA7020S and GA9020/GA9020S/GA7021, and they are not interchangeable between the models. Be careful not to confuse them.

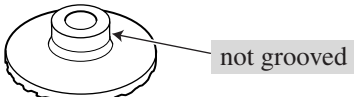
Model No.	No load speed: min-1	Small spiral bevel gear (Gear on Armature shaft)	Large spiral bevel gear (Gear on Spindle)
GA7020 GA7020S	8,500	Spiral bevel gear 16 Number of teeth: 16 	Spiral bevel gear 53B Number of teeth: 53  grooved
GA9020 GA9020S GA7021	6,600 (USA, Guam: 6,000)	Spiral bevel gear 12 Number of teeth: 12 	Spiral bevel gear 53A Number of teeth: 53  not grooved

[3] -1. Armature, Small spiral bevel gear, Ball bearing 6301DDW

DISASSEMBLING

- 1) After removing Carbon brush, separate the assembly of Gear housing complete with Armature from Motor housing complete by unscrewing four M5x35 Tapping screws.
- 2) Separate Bearing box from Gear housing complete by unscrewing four M6x22 Hex socket head bolts.
- 3) With Armature securely held by hand, remove Hex nut M8 from the drive-end of Armature shaft by turning counterclockwise with wrench 13. (**Fig. 1**)
- 4) Hold Small spiral bevel gear by hand, then pull off Armature from Gear housing complete. (**Fig. 2**)

Note: If it is difficult to pull off Armature by hand, do the following steps.

 1. Lubricate small spiral bevel gear and Armature shaft with spray lubricant.
 2. Wrap the gear with cloth to protect the gear teeth.
 3. Using water pump pliers or the like, firmly grip the gear wrapped with cloth, then turn the gear.

Fig. 1

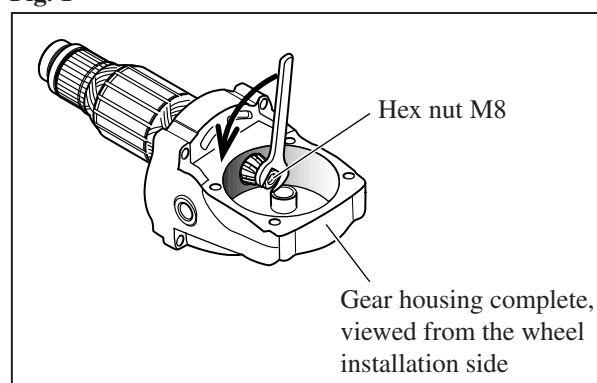
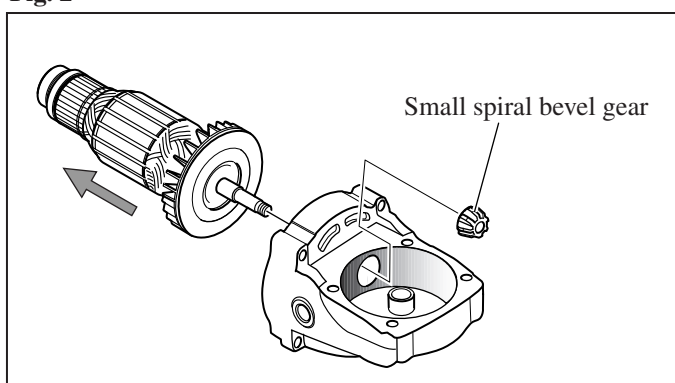

Fig. 2



► Repair

[3] -1. Armature, Small spiral bevel gear, Ball bearing 6301DDW (cont.)

DISASSEMBLING

- 5) In order to remove Ball bearing 6301DDW from gear housing complete, first remove Retaining ring R-42 with Retaining ring R pliers RT-2N (No.1R005), and remove Flat washer 20 from Gear housing complete. (**Fig. 3**)
- 6) Reassemble Armature to Gear housing complete, then the spiral bevel gear to Armature shaft. Tighten Hex nut M8 provisionally by turning clockwise. (Refer to **Fig. 2, 1**)
- 7) By tapping the end of Gear housing complete with a plastic hammer, Ball bearing 6301DDW can be removed together with Armature. (**Fig. 4**)
- 8) Remove Ball bearing 6200DDW from Armature with Bearing Extractor (No.1R269). (**Fig. 5**)

Fig. 3

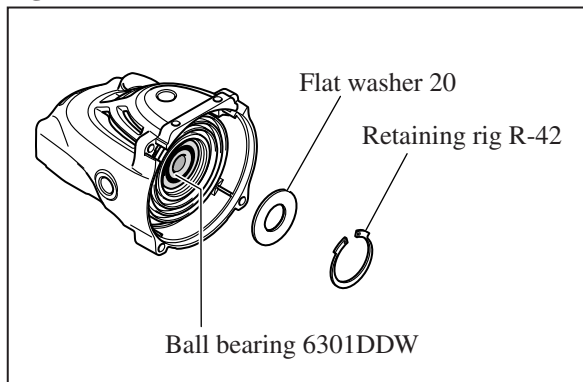

Fig. 4

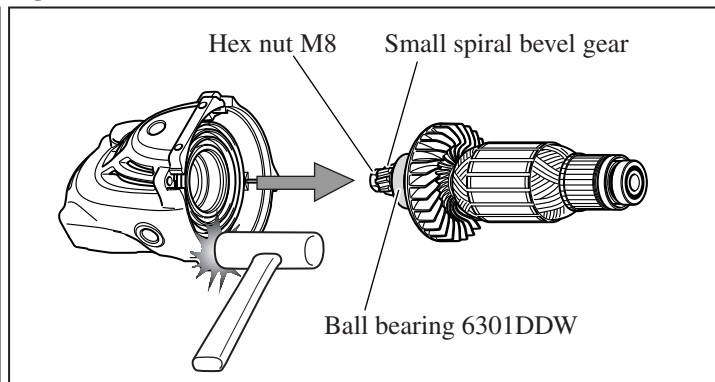
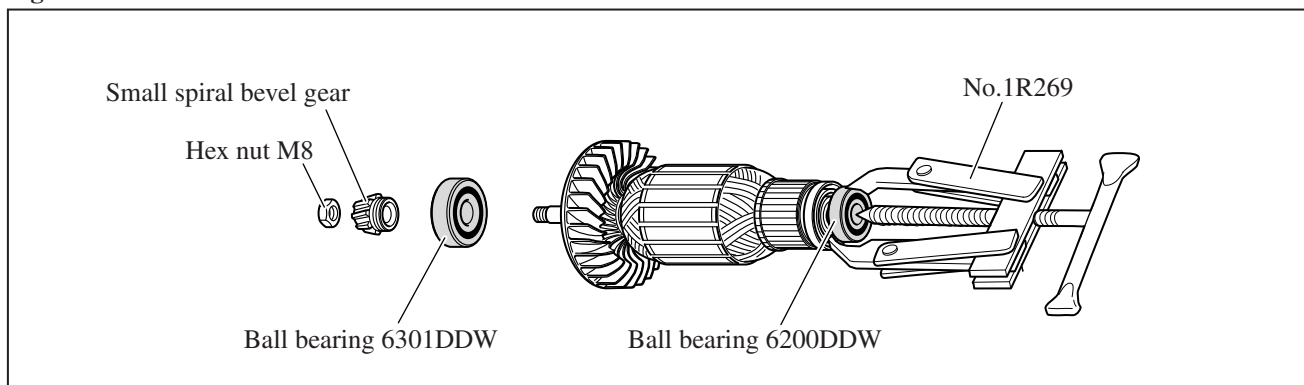

Fig. 5



ASSEMBLING

- 1) Mount Ball bearing 6301DDW on Armature by hand, then insert into the bearing installation hole of Gear housing, (Fig. 8) Then pull off Armature.
- 2) Put Flat washer 20 onto Ball bearing 6301DDW, and fasten with Retaining ring R-42.
- 3) Then do the reverse of the disassembling steps.

Fig. 6

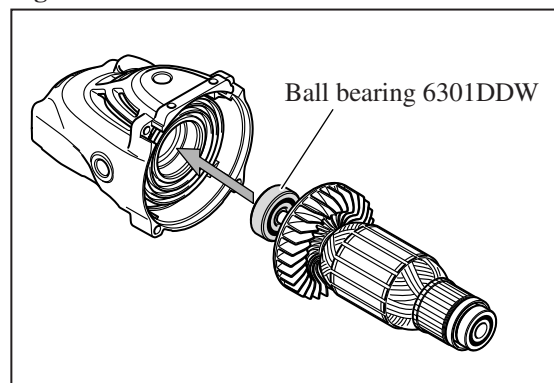

► Repair

[3] -2. Large spiral bevel gear and Ball bearing 6203DDW

Note: The gear and the ball bearing can be replaced without disassembling the Motor section.

DISASSEMBLING

- 1) Separate Bearing box from Gear housing complete by unscrewing four M6x22 Hex socket head bolts.
It is not necessary to remove Carbon brushes.
- 2) Remove Ball bearing 6000ZZ with Bearing Extractor (No.1R269). (**Fig. 7**)
- 3) Insert two Drill chuck removers (No.1R048, 1R049) between Large spiral bevel gear and Bearing box, and set the Bearing box on the turn base of arbor press so that the wheel cover installation surface of Bearing box is placed on the edge of the U-shaped notch of the turn base.
Then remove spindle by pressing down with arbor. (**Fig. 8**)

Fig. 7

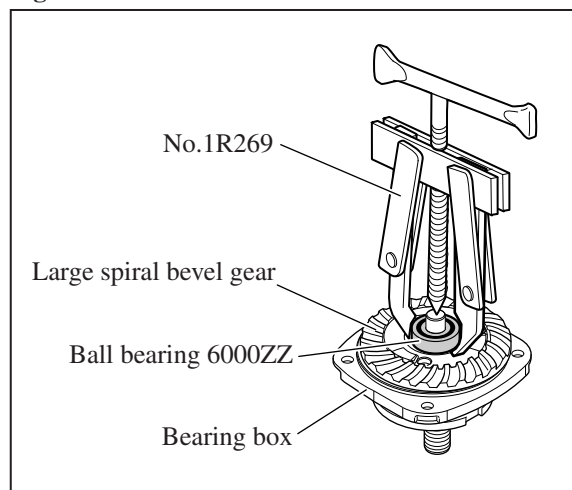
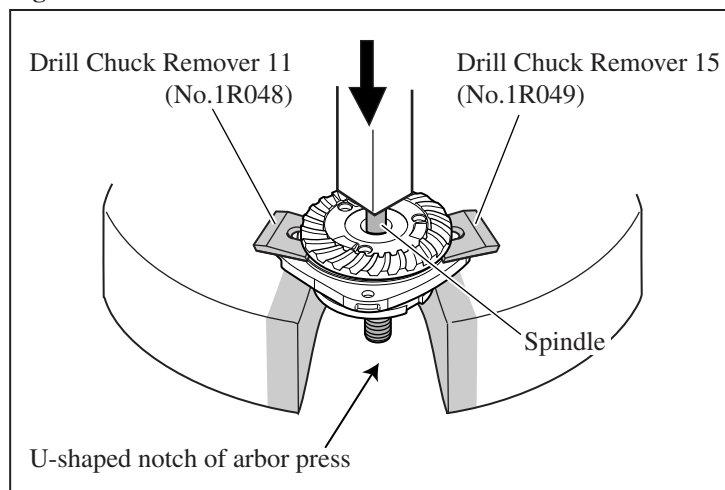

Fig. 8



- 4) After removing Large spiral bevel gear, separate Bearing retainer 50 by removing three M5x16 Pan head screws. (**Fig. 9**)
- 5) Remove Ball bearing 6203DDW by hitting Bearing box straight down against flat surface of work-bench. (**Fig. 10**)
If cannot be removed, use arbor press and a round bar for arbor of an appropriate size as illustrated in **Fig. 11**.

Fig. 9

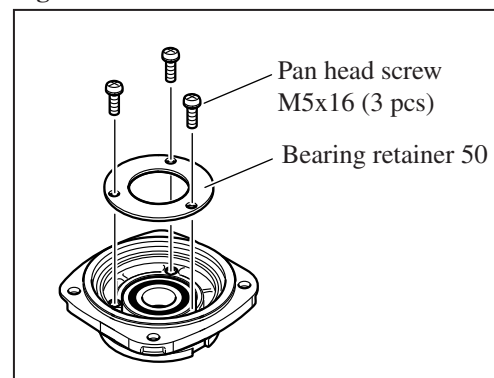

Fig. 10

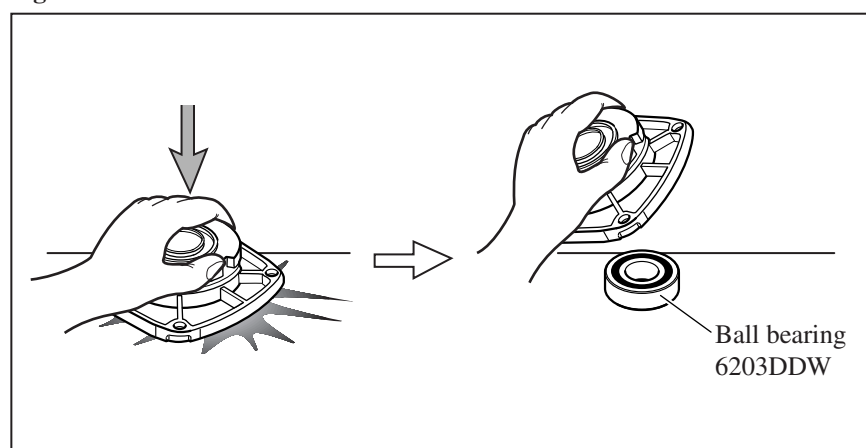
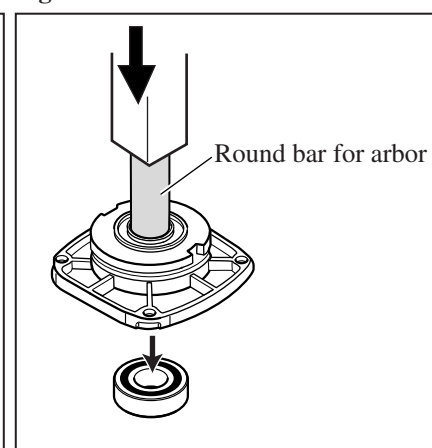

Fig. 11



► Repair

[3] -2. Large spiral bevel gear and Ball bearing 6203DDW (cont.)

ASSEMBLING

Do the reverse of the disassembling steps.

How to assemble Spindle to Large spiral bevel gear

See Fig. 12.

- 1) In order not to damage the gear teeth of Large spiral bevel gear, put it on Ring spring setting tool B (No.1R165).
- 2) After assembling Ball bearing 6203DDW to Bearing box, put Bearing box on Large spiral bevel gear.
- 3) Then press-fit Spindle into Large spiral bevel gear using arbor press.

Fig. 12

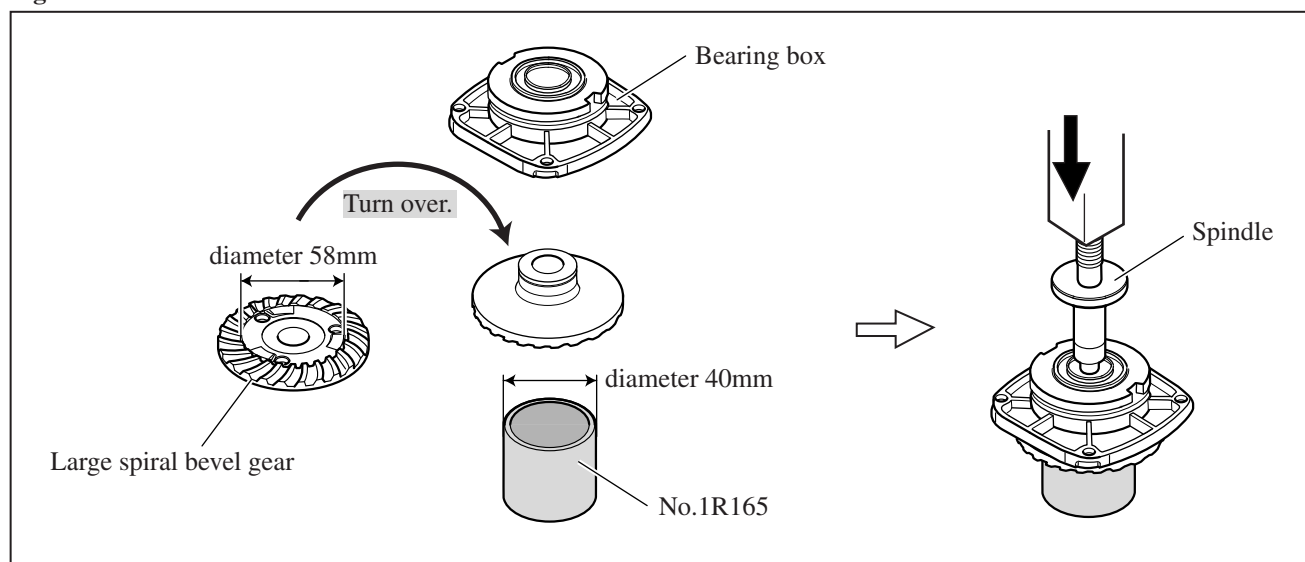

[3] -3. Shaft Lock

DISASSEMBLING

- 1) Remove Bearing box from Gear housing.
- 2) Pull off Shoulder pin 5 with pliers while pushing Pin cap with a finger. (Fig. 13)

Note: Do not pull off shoulder pin 5 without holding pin cap because Compression spring 12 would sling Pin cap.

ASSEMBLING

Follow the reverse of disassembling steps.

Note: Do not reinstall removed Pin cap because removal of Shoulder pin 5 damages the inside surface of Pin cap. Be sure to remove plastic dust of Pin cap from Shoulder pin 5 and to install it onto a brand-new Pin cap.

Fig. 13

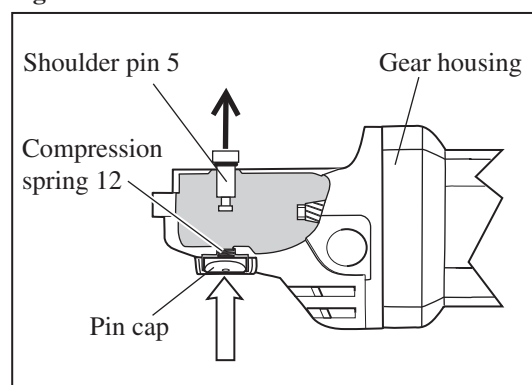

▶ Circuit diagram

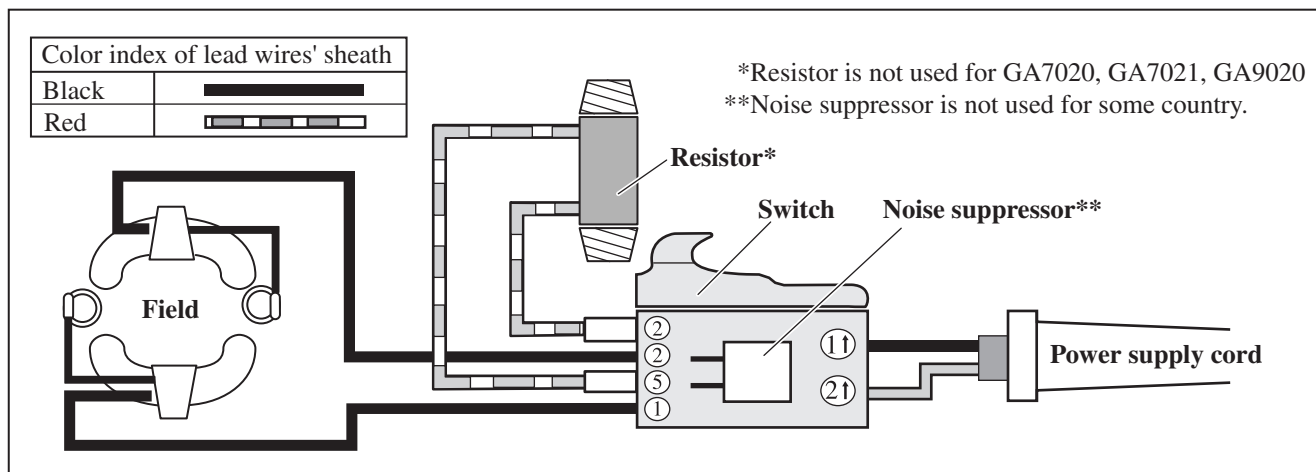

▶ Wiring diagram

[1] Motor Housing

Route two Field lead wires (black) as illustrated below.

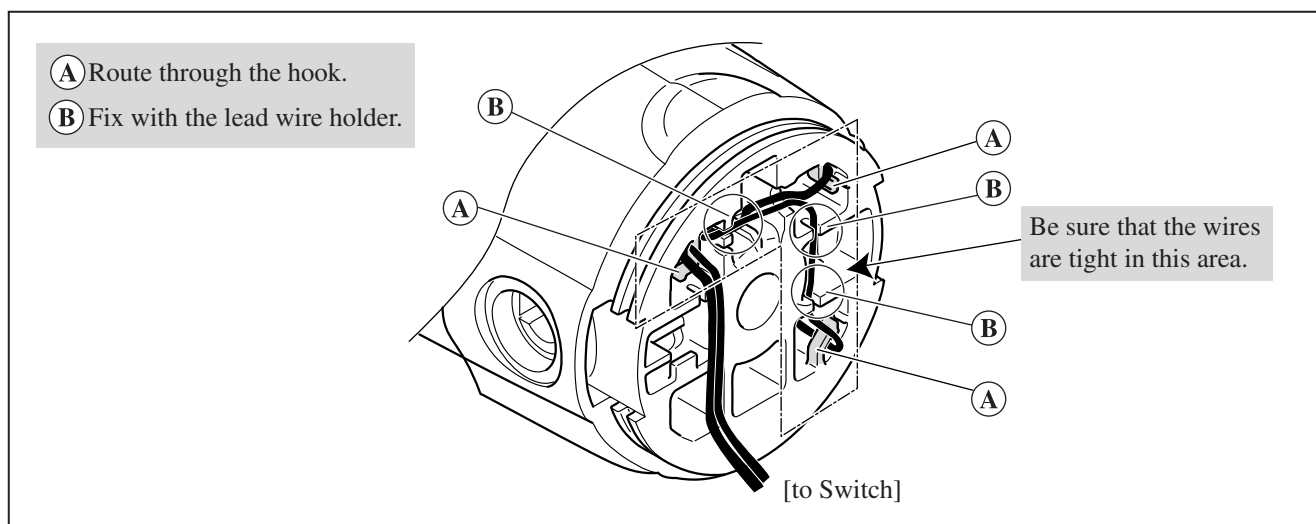

[2] Handle

