

# TECHNICAL INFORMATION



PRODUCT

P 1 / 7

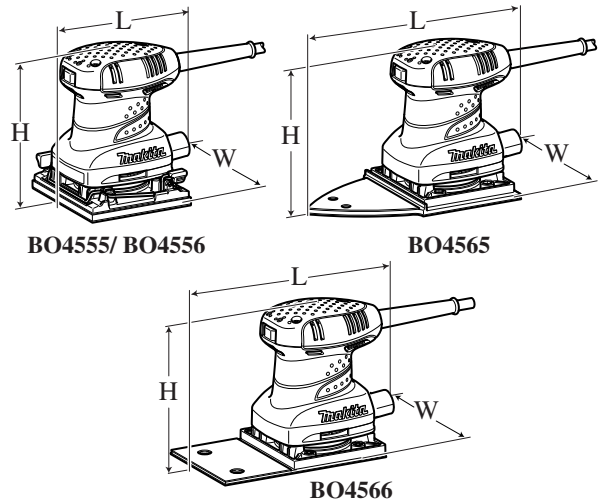
**Model No.** ▶ BO4555, BO4556, BO4565, BO4566

**Description** ▶ Finishing Sander

## CONCEPT AND MAIN APPLICATIONS

These four Finishing sanders have been developed as the successor models of BO4552 series models, featuring ergonomically contoured grip with non-skid elastomer coated surface.

Models BO4565 and BO4566 feature extended pad optimum for corner sanding.



	Dimensions: mm (")			
	BO4555	BO4556	BO4565	BO4566
Length (L)	131 (5-1/8)		219 (8-5/8)	197 (7-3/4)
Width (W)	112 (4-3/8)		100 (3-15/16)	
Height (H)	142 (5-5/8)	141 (5-9/16)	139 (5-1/2)	137 (5-3/8)

## ► Specification

### BO4555/ BO4556

Voltage (V)	Current (A)	Cycle (Hz)	Continuous Rating (W)		Max. Output (W)
			Input	Output	
110	1.9	50/60	200	60	90
120	2.0	50/60	---	60	90
220	1.0	50/60	200	60	90
230	1.0	50/60	200	60	90
240	0.9	50/60	200	60	90

### BO4565/ BO4566

220	1.0	50/60	200	60	90
230	1.0	50/60	200	60	90
240	0.9	50/60	200	60	90

Specification		Model	BO4555	BO4556	BO4565	BO4566
Orbits per minute: opm= min-1			14,000			
Sanding strokes: spm= min-1			28,000			
Paper fastening system	Hook & loop		Yes	No	Yes	
	Clamp		Yes	Yes	No	
Pad	Shape		Standard		Extended, Triangular	Extended, Rectangular
	Size: mm (")		112 x 102 (4-3/8 x 4)		112 x 190 (4-3/8 x 7-1/2)	100 x 164 (3-15/16 x 6-1/2)
Abrasive paper size: mm (")			Hook & loop system: 114 x 102 (4-1/2 x 4) Clamp system: 114 x 140 (4-1/2 x 5-1/2)		Triangle paper: 96 (3-3/4) Square paper: 114 x 102 (4-1/2 x 4)	102 x 166 (4 x 6-1/2) 102 x 240 (4 x 9-1/2)
Double insulation			Yes			
Power supply cord: m (ft)			2.0 (6.6)			
Net weight: kg (lbs)			1.1 (2.4)			

See next page for "Standard equipment" and "Optional accessories".

## ► Standard equipment

### BO4555

#### [When using Hook & loop system]

Abrasive paper 60 .....	1
Abrasive paper 100 .....	1
Abrasive paper 150 .....	1
Paper bag + Paper dust bag holder or Dust bag assembly .....	1
Punch plate .....	1
Plastic carrying case .....	1

### BO4556

Abrasive paper 114-60 .....	1
Abrasive paper 114-100 .....	1
Abrasive paper 114-150 .....	1
Paper bag + Paper dust bag holder or Dust bag assembly .....	1
Punch plate .....	1
Plastic carrying case .....	1

### BO4566

Paper bag + Paper dust bag holder or Dust bag assembly .....	1
---	---

**Note:** The standard equipment for the tool shown above may differ by country.

## ► Optional accessories

### BO4555/ BO4556

Abrasive paper 40, 60, 100, 150, 240  
Abrasive paper 114-60, 114-80, 114-100, 114-150

### BO4565

Abrasive paper 96-40, 96-60, 96-100, 96-150, 96-240  
Abrasive paper 40, 60, 100, 150, 240

### BO4555

#### [When using Clamp system]

Abrasive paper 114-60 .....	1
Abrasive paper 114-100 .....	1
Abrasive paper 114-150 .....	1
Paper bag + Paper dust bag holder or Dust bag assembly .....	1
Punch plate .....	1
Plastic carrying case .....	1

### BO4565

Abrasive paper 60 .....	1
Abrasive paper 100 .....	1
Abrasive paper 150 .....	1
Abrasive paper 96-60 .....	1
Abrasive paper 96-100 .....	1
Abrasive paper 96-150 .....	1
Paper bag + Paper dust bag holder or Dust bag assembly .....	1
Plastic carrying case .....	1

## ► Repair

**CAUTION: Unplug the machine for safety before repair/ maintenance, in accordance with the instruction manual!**

### [1] NECESSARY REPAIRING TOOLS

Code No.	Description	Use for
1R027	Bearing setting pipe 18-10.2	Removing Armature from Bearing box
1R269	Bearing extractor	Removing Ball bearings from Armature

### [2] LUBRICATION

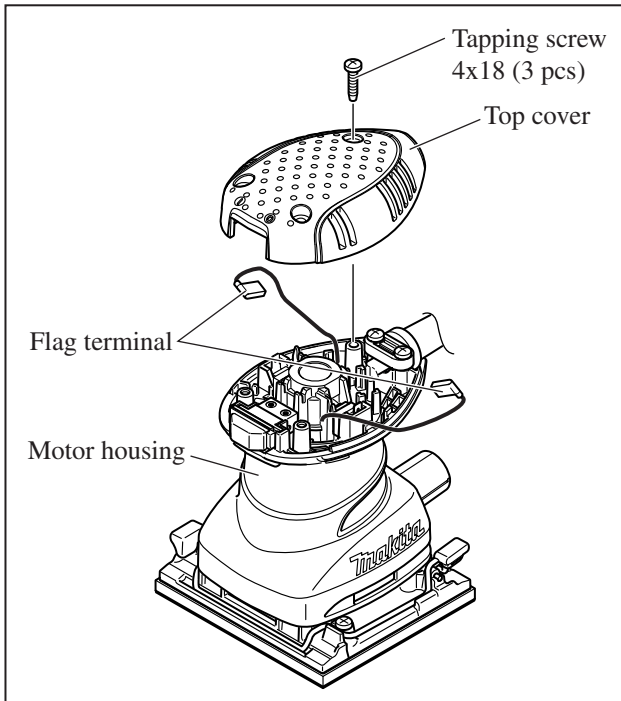
Lubrication is not required for this product because no gear is used for transmission.

### [3] DISASSEMBLY/ASSEMBLY

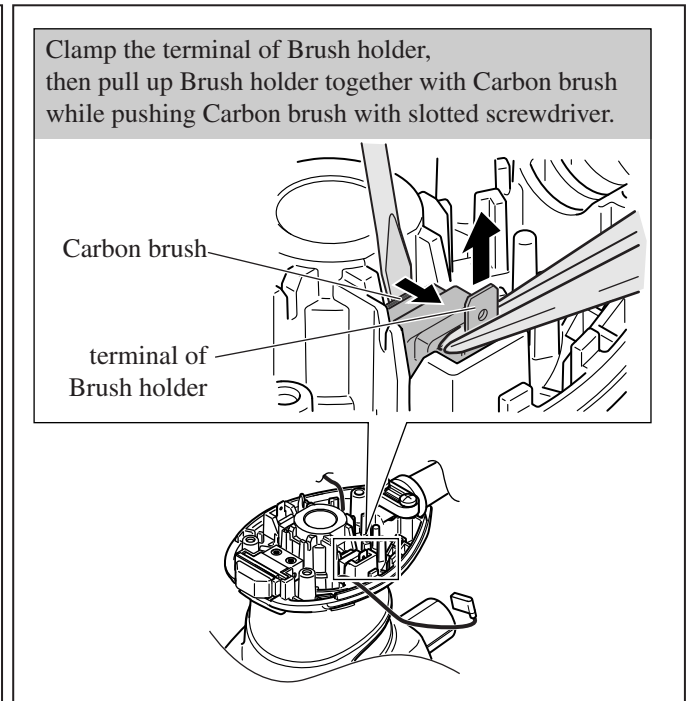
#### DISASSEMBLING

- 1) Remove Top cover from Motor housing by unscrewing three 4x18 Tapping screws, then disconnect Flag terminal from each Brush holder. (**Fig. 1**)
- 2) Carbon brush can be removed from Motor housing together with Brush holder as described in **Fig. 2**.

**Fig. 1**

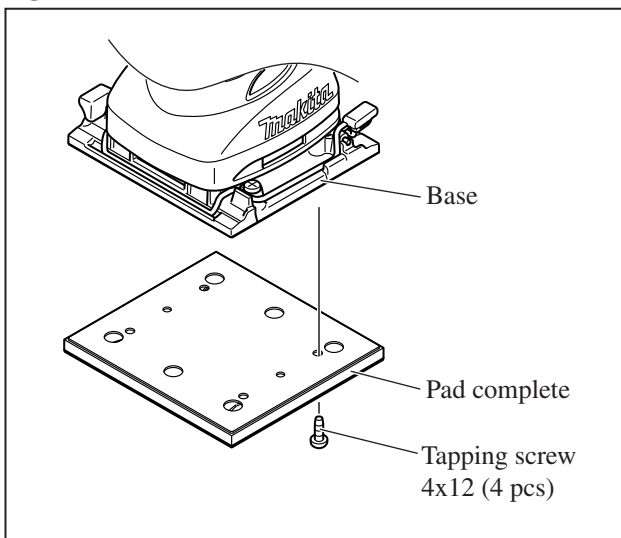


**Fig. 2**

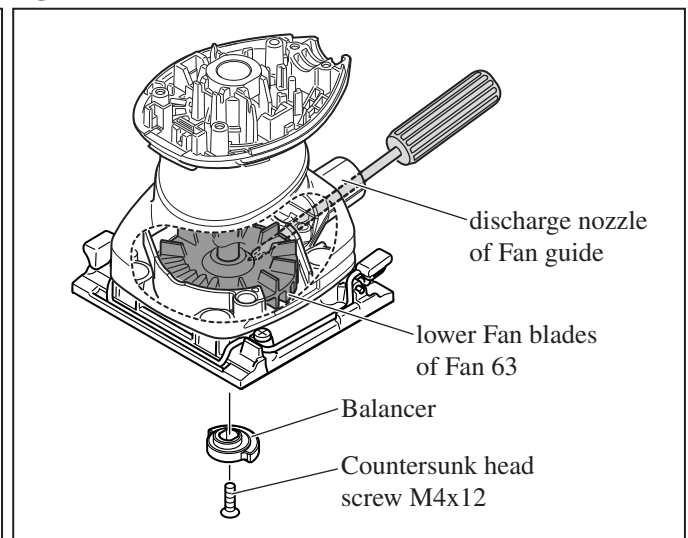


- 3) Remove Pad complete from Base by unscrewing four 4x12 Tapping screws. (**Fig. 3**)
- 4) Lock Armature shaft by inserting screwdriver from the discharge nozzle of Fan guide between the lower Fan blades of Fan 63 as illustrated in **Fig. 4**. Balancer can now be removed by removing Countersunk head screw M4x12 from Armature shaft.

**Fig. 3**



**Fig. 4**



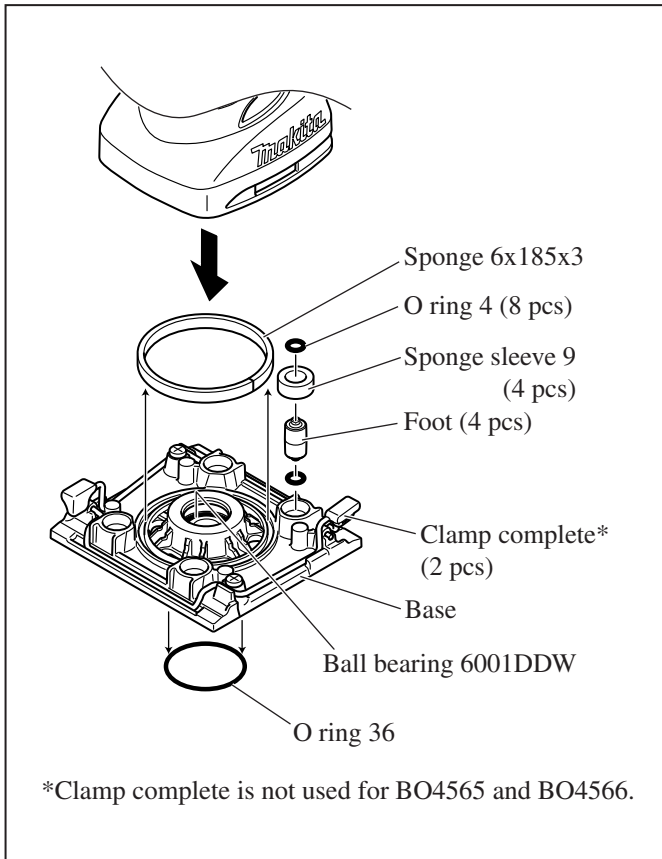
► **Repair**

**[3] DISASSEMBLY/ASSEMBLY**

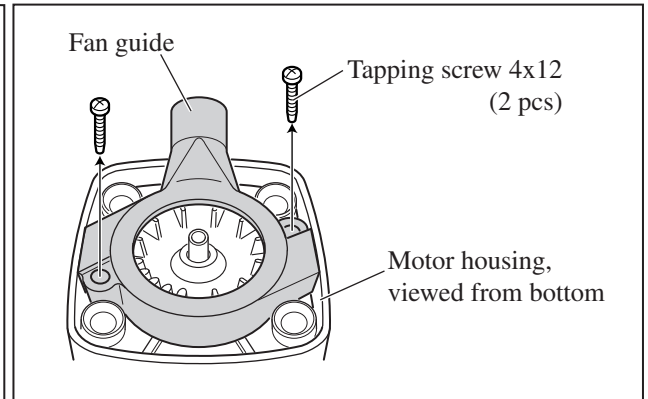
DISASSEMBLING

- 5) Remove Base from Motor housing. Some adjacent parts can be also removed in this step as illustrated in **Fig. 5**.
- 6) Remove Fan guide from Motor housing by unscrewing two 4x12 Tapping screws. (**Fig. 6**)
- 7) Remove Fan 63, then remove four 4x18 Tapping screws. (**Fig. 7**)

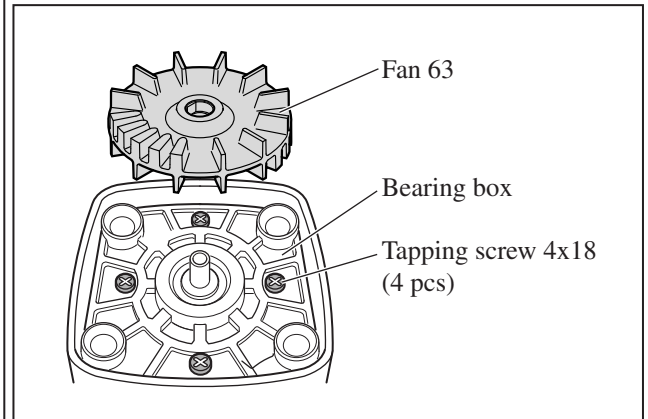
**Fig. 5**



**Fig. 6**

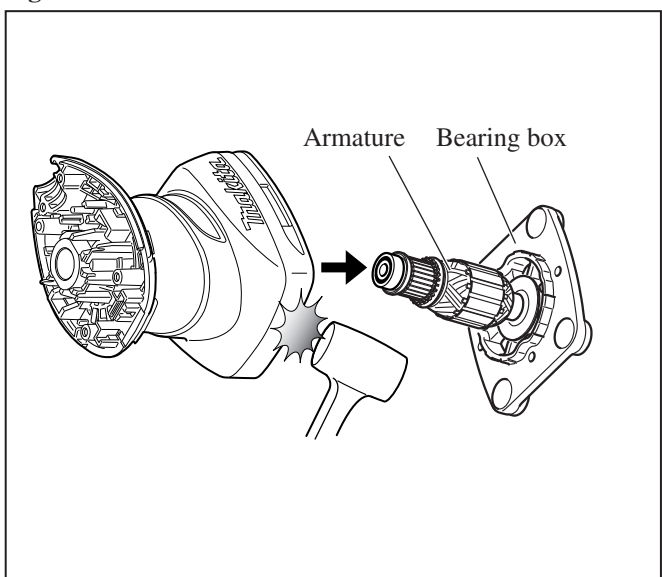


**Fig. 7**

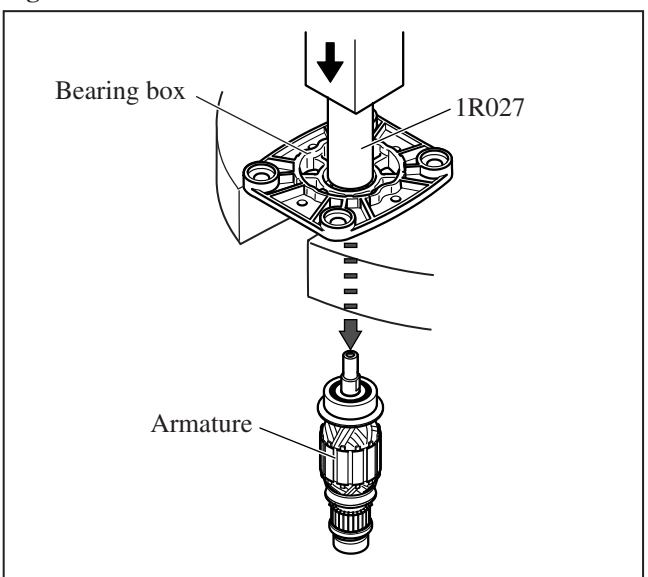


- 8) Bearing box and Armature can now be removed as an assembly by tapping the end surface of Motor housing with plastic hammer. (**Fig. 8**)
- 9) Remove Armature from Bearing box using 1R027 and arbor press. (**Fig. 9**)

**Fig. 8**



**Fig. 9**



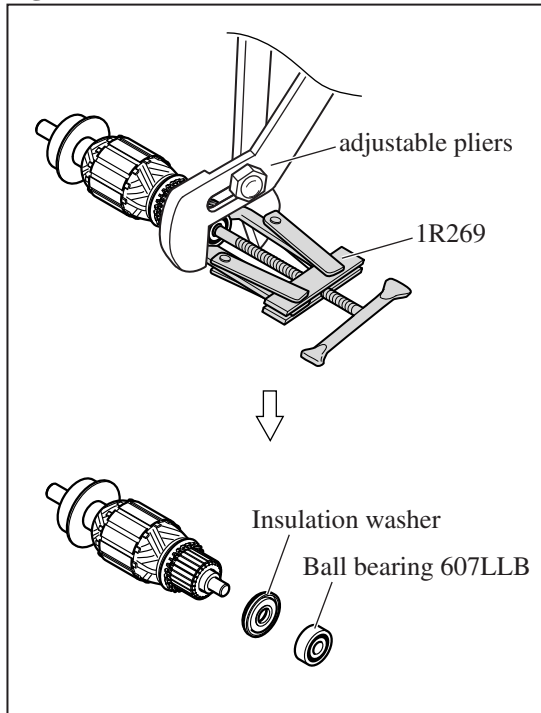
## ► Repair

### [3] DISASSEMBLY/ASSEMBLY

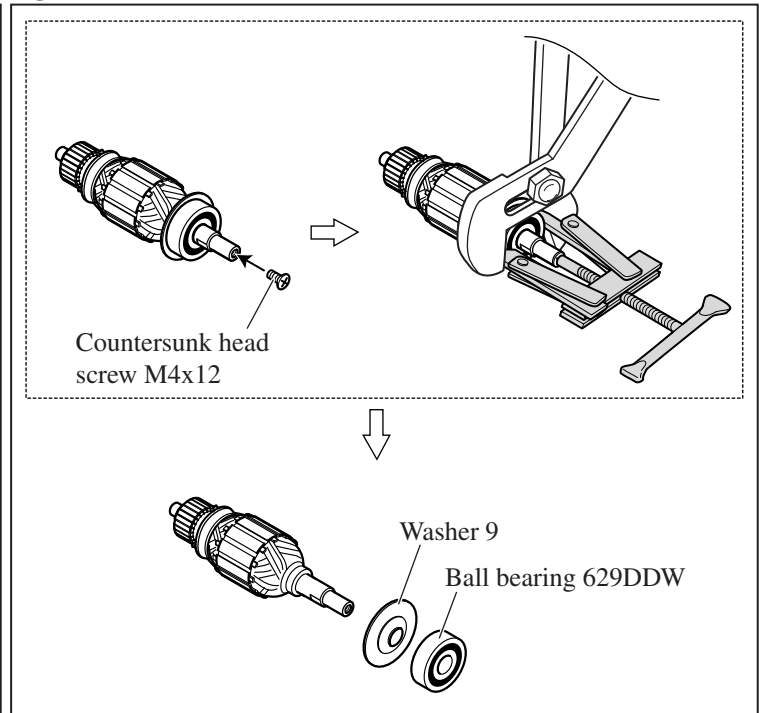
#### DISASSEMBLING

- 10) Remove Ball bearing 607LLB from the commutator-end of Armature shaft using 1R269 and adjustable pliers (**Fig. 10**),  
**Note:** Be sure to firmly grasp the claws of 1R269 with adjustable pliers because the space between Insulation washer and Ball bearing 607LLB is so tight that Ball bearing 607LLB cannot be securely grasped with the claws of 1R269.
- 11) Remove Ball bearing 629DDW from the drive-end of Armature shaft using 1R269 and adjustable pliers in the same way as described above in 10). (**Fig. 11**)  
**Important:** Before attaching 1R269 to Ball bearing 629DDW, be sure to fasten Countersunk head screw M4x12 to the drive-end of Armature shaft in order not to damage to the threads inside Armature shaft.

**Fig. 10**



**Fig. 11**



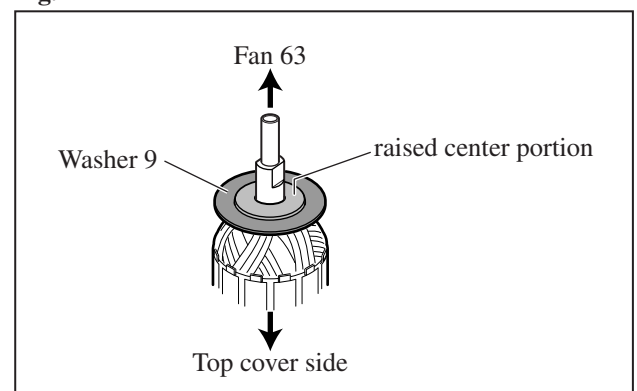
#### ASSEMBLING

Do the reverse of the disassembling steps.

**Note:**

Flat washer 9 is not reversible when assembled to Armature. The side with the raised center portion must face towards Fan 63 as illustrated in **Fig. 12**.

**Fig. 12**



## ► Repair

### [3] DISASSEMBLY/ASSEMBLY

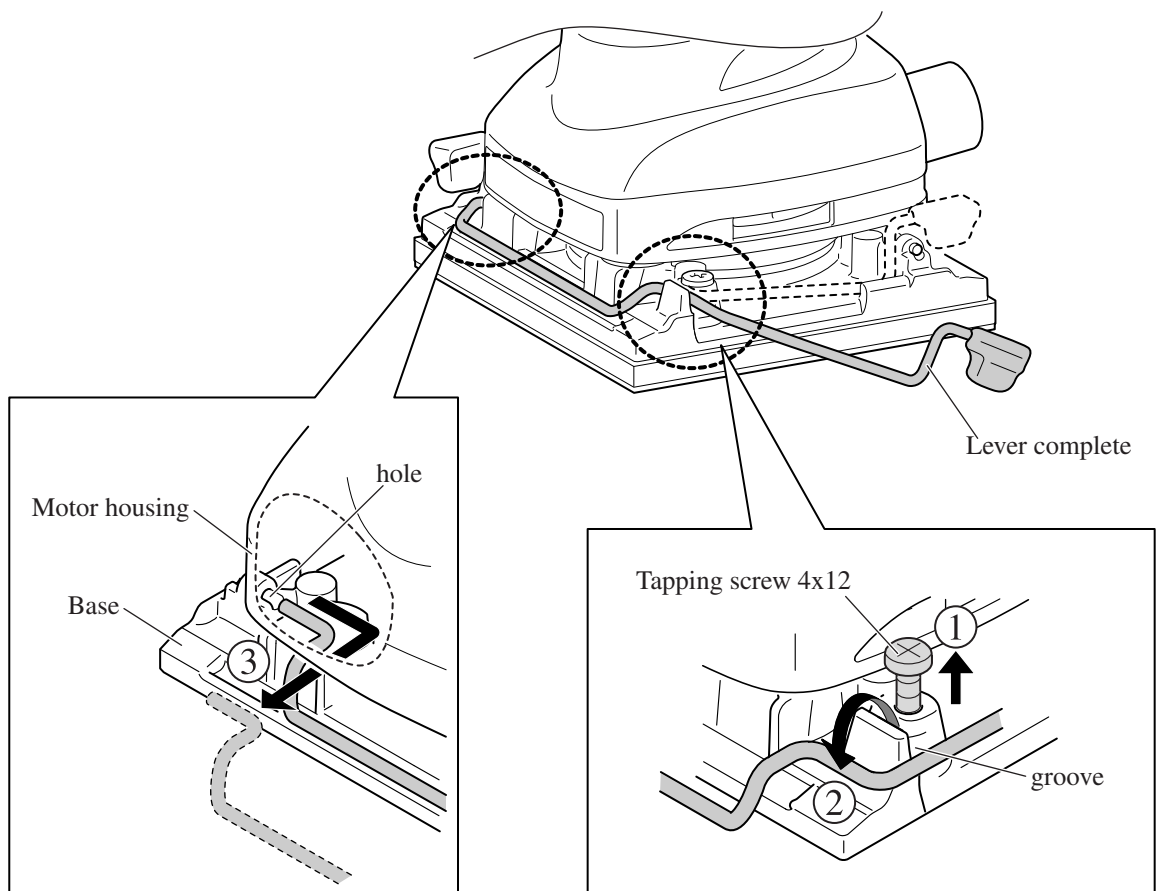
#### REPLACING LEVER COMPLETE (BO4555 and BO4556 only)

Lever complete (=paper clamp) can be replaced without removing Base from the machine as described in **Fig. 13**.

**Fig. 13**

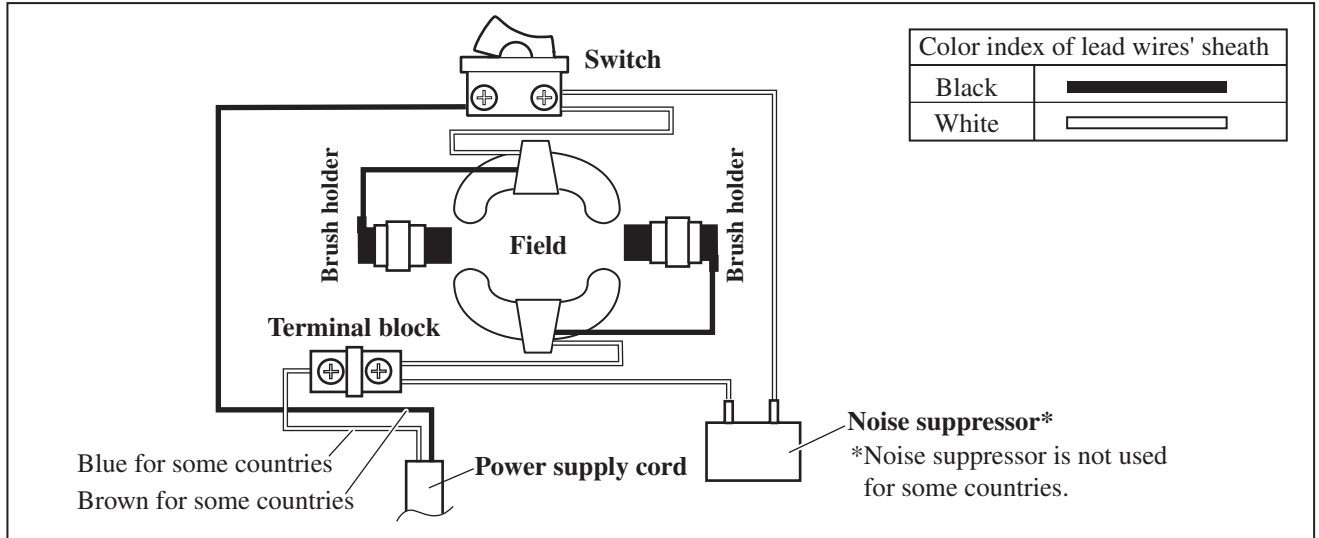
Take the following steps:

- ① Loosen Tapping screw 4x12 a little bit.
- ② Pull Lever complete out of the groove.
- ③ Pull the end of Lever complete out of the hole, then move Lever complete along the space between Base and Motor housing.



## ► Circuit diagram

Fig. D-1



## ► Wiring diagram

Route Lead wires as illustrated in Fig. D-2.

- ① ④ Field lead wire (black):  
Route through the opening 1/opening 2 of Motor housing, then connect to Brush holder.  
**Note:** Be sure to fix with Lead wire holder 1/  
Lead wire holder 6.
  - ② Field lead wire (white):  
Route through the opening 1 of Motor housing, then connect to Switch.  
**Note:** Be sure to fix with Lead wire holders 2, 3.
  - ③ Lead wire of Noise suppressor (white):  
Connect to Switch.  
**Note:** Be sure to fix with Lead wire holders 4, 5.
  - ⑤ Field lead wire (white):  
Route through the opening 2 of Motor housing, then connect to Terminal block.
  - ⑥ Lead wire (white) of Noise suppressor:  
Connect to Terminal block.
  - ⑦ Lead wire (white or blue) of Power supply cord:  
Connect to Terminal block.
  - ⑧ Lead wire (black or brown) of Power supply cord:  
Connect to Switch.  
**Note:** Be sure to route through the groove of Motor housing.
- Note:** Put slack portions of Lead wires in spaces 1 and 2.

Fig. D-2

